

# H9015

## FOR 9000 SERIES CHERRY® RIVETS

TECHNICAL DATA SHEET, Page 1 of 2



**CHERRY®**  
AEROSPACE

### DIMENSIONAL DATA

3/32"	H9015-3C
1/8"	H9015-4C
5/32"	H9015-5C
3/16"	H9015-6C

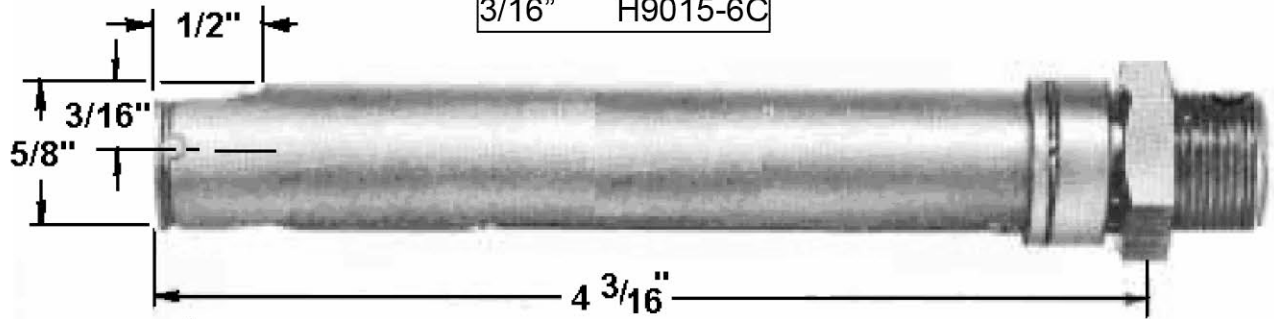

### CHOICE OF RIVETERS

- These heads fit directly on the G902-15 Cherry® power riveter.
- They also fit directly on older Cherry power riveters such as the G715A.
- Will fit on the CherryMAX® riveters (G704B, G746A and G74) with the 704A9 adapter.

### BEFORE USE, CHECK IF:

- The Pulling Head is correctly mounted and the proper riveter is selected.
- Proper Air source is connected (see Riveter specification for recommended pressure).
- The appropriate Nose Piece is used and the tool is clean and in good working condition.

### USAGE

- 3/32", 1/8", 5/32" AND 3/16" CHERRY® rivets, 9000 series.
- The Countersunk version of the H9015 Series will install both flush and universal head rivets.

### DURING OPERATION

- Inspect the active area of the Nosepiece regularly.
- Keep the tool clean, especially the Nosepiece and Jaws; pay special attention when used with sealants and adhesives.
- If stem slippage occurs, the Jaws need to be either cleaned or replaced.

USATCO U.S. Air Tool Company, Inc.

Eastern Division .....60 Fleetwood Ct., Ronkonkoma, NY 11779-6907 tel: (631) 471-3300 fax: (631) 471-3308  
Western Division .....1219 W. Mahalo Place, Rancho Dominguez, CA 90220-5446 tel: (310) 632-5400 fax: (310) 632-3900

[Info@usatco.com](mailto:Info@usatco.com)

# H9015

## FOR 9000 SERIES CHERRY® RIVETS

TECHNICAL DATA SHEET, Page 2 of 2



**CHERRY®**  
AEROSPACE

### PARTS LIST

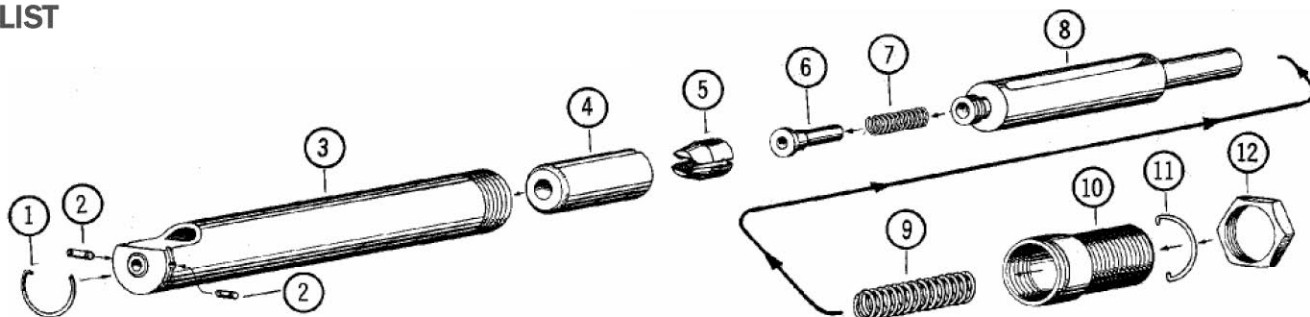

Ref. No	Description	Qty	Head Number			
			H9015-3C	H9015-4C	H9015-5C	H9015-6C
1	Spring, Stem Stop	1	711A9	711A9	711A9	711A9
2	Stem Stop	2	712A10-1	712A10-1	712A10-2	712A10-2
3	Sleeve, Countersink head	1	711 C2-3C	711 C2-4C	711 C2-5C	711 C2-6C
4	Collet	1	711B4	711B4	711B4	711B4
5	Jaws	1 set	711 B6-3	711 B6-4	711 B6-5	711 B6-6
6	Jaw Follower	1	711A7	711A7	711A7	711A7
7	Spring, Follower	1	711A8	711A8	711A8	711A8
8	Drawbolt	1	711 B5	711 B5	711 B5	711 B5
9	Spring, return	1	P1158	P1158	P1158	P1158
10	Retainer Cap	1	711B12	711B12	711B12	711B12
11	Spring, Retainer Cap	1	680A25	680A25	680A25	680A25
12	Jam Nut	1	G6JN	G6JN	G6JN	G6JN

### PREVENTATIVE MAINTENANCE

- Inspect active area regularly and keep it clean, in good condition
- Clean the jaws and jaw jevity inside the Collet every 1,000 installations.
- Lubricate outside configuration of the jaws with Lubriplate® or similar light grease.
- Use Loctite® 242 (removable) on threaded components.

LOCTITE® is a registered trademark of Henkel Corporation.

LUBRIPLATE® is a registered trademark of Fiske Brothers Refining Co.

### WARRANTY

Seller warrants the goods conform to applicable specifications and drawings and will be manufactured and inspected according to generally accepted practices of companies manufacturing industrial or aerospace fasteners. In the event of any breach of the foregoing warranty, Buyer's sole remedy shall be to return defective goods (after receiving authorization from Seller) for replacement or refund of the purchase price, at the Seller's option. Seller agrees to any freight costs in connection with the return of any defective goods, but any costs relating to removal of the defective or nonconforming goods or installation of replacement goods shall be Buyer's responsibility. SELLER'S WARRANTY DOES NOT APPLY WHEN ANY PHYSICAL OR CHEMICAL CHANGE IN THE FORM OF THE PRODUCT IS MADE BY BUYER. THE FOREGOING EXPRESS WARRANTY AND REMEDY ARE EXCLUSIVE AND ARE IN LIEU OF ALL OTHER WARRANTIES AND REMEDIES; ANY IMPLIED WARRANTY AS TO QUALITY, FITNESS FOR PURPOSE, OR MERCHANTABILITY IS HEREBY SPECIFICALLY DISCLAIMED AND EXCLUDED BY SELLER. This warranty is void if seller is not notified in writing of any rejection of the goods within ninety (90) days after receipt of the goods by buyer.

Seller shall not be liable under any circumstances for incidental, special or consequential damages arising in whole or in part from any breach by Seller, AND SUCH INCIDENTAL, SPECIAL, OR CONSEQUENTIAL DAMAGES ARE HEREBY EXPRESSLY EXCLUDED.

Our policy is one of continuous development. Specifications shown in this document may be subject to changes introduced after publication.

NOTE: The properties, strength, dimensions, installed characteristics and all other information in these materials are for guidance only to aid in the correct selection of the products described herein and is not intended or implied as part of the above warranty. All applications should be evaluated for functional stability and available samples of the described parts can be requested for installed tests, suitability and evaluations.

For more information please contact our Technical Services Department at tel. 714-850-6022

USATCO U.S. Air Tool Company, Inc.

Info@usatco.com

Eastern Division .....60 Fleetwood Ct., Ronkonkoma, NY 11779-6907 tel: (631) 471-3300 fax: (631) 471-3308

Western Division .....1219 W. Mahalo Place, Rancho Dominguez, CA 90220-5446 tel: (310) 632-5400 fax: (310) 632-3900