

# H563-()B LOCKBOLT OFFSET PULLING HEAD

Technical Data Sheet, Page 1 of 2



**CHERRY®**  
**AEROSPACE**  
SPS Fastener Division, a PCC Company

## DIMENSIONAL DATA (all measurements in Inches)

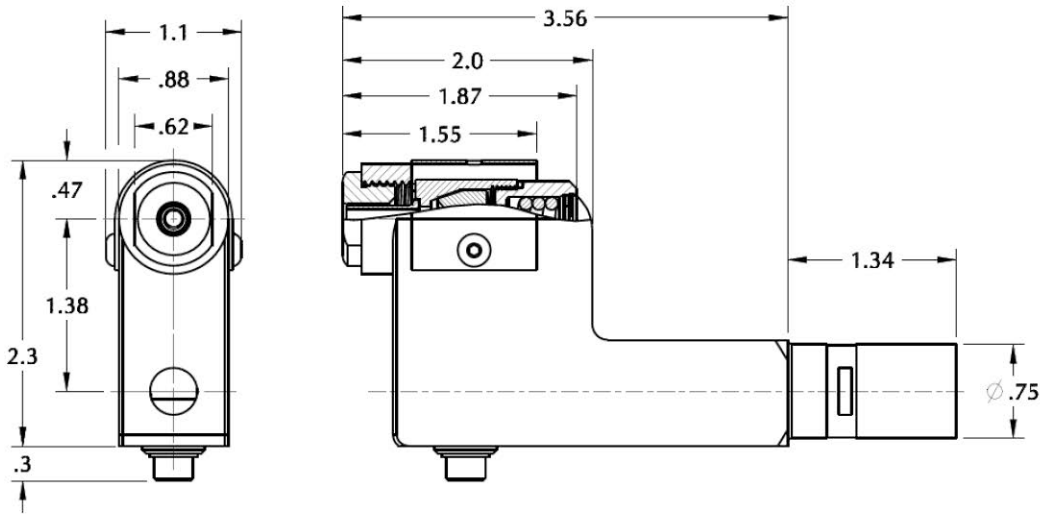

## SIZE DEPENDENT COMPONENT CHOICE (see exploded view on second page for ref. numbers)

REF NO.	ASSEMBLY PART NO. FOR 3/8 NOSE PROJECTION			ASSEMBLY PART NO. FOR SHORT PINTAIL LOCKBOLTS USING LETTER "Y"		
	H563-4B	H563-5B	H563-6B	H563SP-4B	H563SP-5B	H563SP-6B
-1	563B2	563B2	563B2	563B12	563B12	563B12
-11	562A6-4	562A6-5	562A6-6	563A14-4	563A14-5	563A14-6
-12	563A9-4	563A9-5	563A9-6	563A13-4	563A13-5	563A13-6
-13	P-609	513-077	563-031	P-609	513-077	563-031
-15	563B25-4	563B25-5	563B25-6	563B25-4	563B25-5	563B25-6

## CHOICE OF RIVETERS

- G83 & G84 Riveters
- G84-LS Split Power Riveter (with adaptor 744-700)
- G85D & G87D Riveter (with adaptor 552)

## MOUNTING INSTRUCTIONS

- Attach riveter to air source for correct piston positioning.
- Thread Collet Assembly securely onto the riveter head piston.
- Depress the trigger and attach the sleeve assembly onto the bayonet mount.

## BEFORE USE, MAKE SURE THAT:

- The correct pulling head and nose piece are used and that they are properly mounted on the recommended riveter.
- Proper air source is connected (see riveter specification for recommended pressure).
- Make sure that the tool is clean and in good working condition

USATCO U.S. Air Tool Company, Inc.

**Info@usatco.com**

Eastern Division .....60 Fleetwood Ct., Ronkonkoma, NY 11779-6907 tel: (631) 471-3300 fax: (631) 471-3308

Western Division .....1219 W. Mahalo Place, Rancho Dominguez, CA 90220-5446 tel: (310) 632-5400 fax: (310) 632-3900

# H563-()B

## LOCKBOLT OFFSET PULLING HEAD

Technical Data Sheet, Page 2 of 2

### PARTS LIST

ITEM	PART	DESCRIPTION	REQ.
1	SLEEVE	SEE TABLE	1
2	563B3	DRAWBOLT	1
3	562A11	SPACER	1
4	P-97	LOCKWASHER	1
5	P-71	SCREW, SOC HD CAP	1
6	563A10	SCREW, BUTTON HEAD	2
7	563A7	GUARD	1
8	563A4	EXTENSION,	1
9	P-240	SCREW, FLAT HD SOC	2
10	563A8	SPRING, RETAINING	1
11	SEE TABLE	ANVIL	1
12	SEE TABLE	SLEEVE, EJECTOR	1
13	SEE TABLE	JAWS	1 SET
14	563A27	ADJUSTING WASHER	1
15	563-B25-()	SNUBBER; SEE TABLE	1

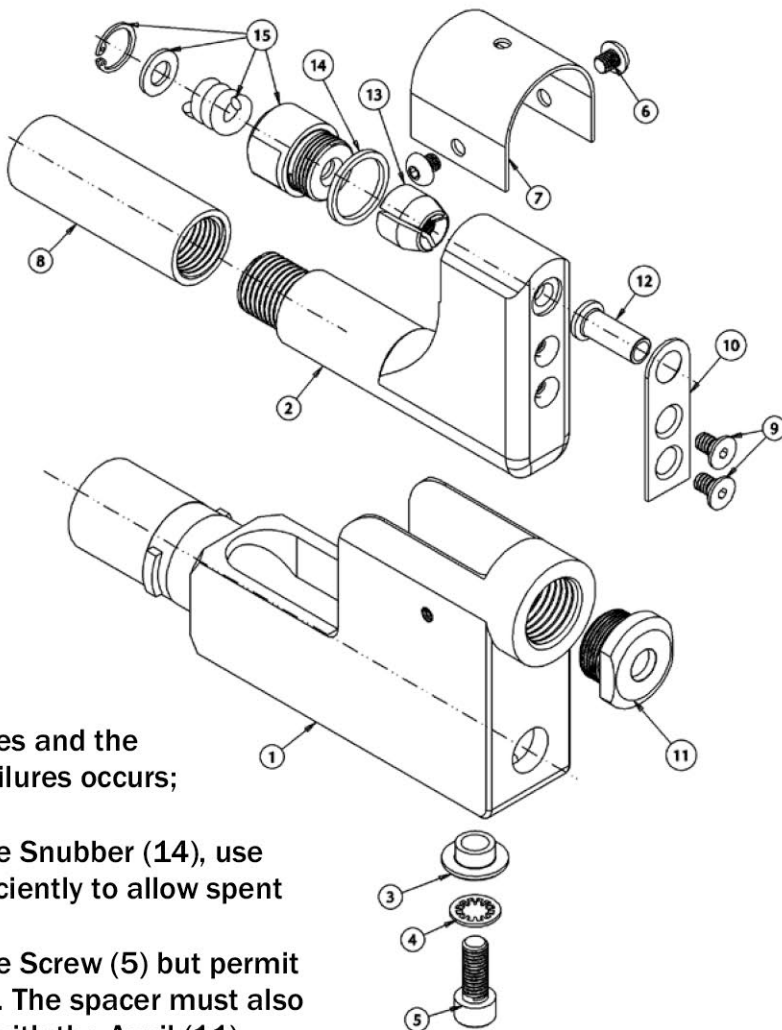

### PREVENTATIVE MAINTENANCE

- Clean the Anvil(11) and Drawbolt(2) cavities and the Jaws every 1,000 installations, or when failures occurs; replace components as needed.
- When assembling the Drawbolt (2) and the Snubber (14), use washer (14) only if jaws cannot open sufficiently to allow spent pintail to pass through.
- Spacer (3) must be secured tightly with the Screw (5) but permit free sliding movement of the Drawbolt (2). The spacer must also hold the Ejector Sleeve (12) in alignment with the Anvil (11).
- Use Loctite 242 (removable) on the threaded components.
- Lubricate outside configuration of the jaw set with Lubriplate® or similar light lubricant.

### WARRANTY

Seller warrants the goods conform to applicable specifications and drawings and will be manufactured and inspected according to generally accepted practices of companies manufacturing industrial or aerospace fasteners. In the event of any breach of the foregoing warranty, Buyer's sole remedy shall be to return defective goods (after receiving authorization from Seller) for replacement or refund of the purchase price, at the Seller's option. Seller agrees to any freight costs in connection with the return of any defective goods, but any costs relating to removal of the defective or nonconforming goods or installation of replacement goods shall be Buyer's responsibility. SELLER'S WARRANTY DOES NOT APPLY WHEN ANY PHYSICAL OR CHEMICAL CHANGE IN THE FORM OF THE PRODUCT IS MADE BY BUYER. THE FOREGOING EXPRESS WARRANTY AND REMEDY ARE EXCLUSIVE AND ARE IN LIEU OF ALL OTHER WARRANTIES AND REMEDIES; ANY IMPLIED WARRANTY AS TO QUALITY, FITNESS FOR PURPOSE, OR MERCHANTABILITY IS HEREBY SPECIFICALLY DISCLAIMED AND EXCLUDED BY SELLER. This warranty is void if seller is not notified in writing of any rejection of the goods within ninety (90) days after receipt of the goods by buyer.

Seller shall not be liable under any circumstances for incidental, special or consequential damages arising in whole or in part from any breach by Seller, AND SUCH INCIDENTAL, SPECIAL, OR CONSEQUENTIAL DAMAGES ARE HEREBY EXPRESSLY EXCLUDED.

Our policy is one of continuous development. Specifications shown in this document may be subject to changes introduced after publication.

NOTE: The properties, strength, dimensions, installed characteristics and all other information in these materials are for guidance only to aid in the correct selection of the products described herein and is not intended or implied as part of the above warranty. All applications should be evaluated for functional stability and available samples of the described parts can be requested for installed tests, suitability and evaluations.

For more information please contact our Technical Services Department at tel. 714-850-6022

LOCTITE® is a registered trademark of Henkel Corporation.

LUBRIPLATE® is a registered trademark of Fiske Brothers Refining Co.

USATCO U.S. Air Tool Company, Inc.

Info@usatco.com

Eastern Division .....60 Fleetwood Ct., Ronkonkoma, NY 11779-6907 tel: (631) 471-3300 fax: (631) 471-3308

Western Division .....1219 W. Mahalo Place, Rancho Dominguez, CA 90220-5446 tel: (310) 632-5400 fax: (310) 632-3900