

135DPV Series Variable Speed Drills



USATCO U.S. Air Tool Company, Inc.

Eastern Division60 Fleetwood Ct., Ronkonkoma, NY 11779-6907 tel: (631) 471-3300 fax: (631) 471-3308

Western Division1219 W. Mahalo Place, Rancho Dominguez, CA 90220-5446 tel: (310) 632-5400 fax: (310) 632-3900

Info@usatco.com

Cleco®
Nomenclature

	135	D	PV	-	XX	B	-	XX
Tool Series								
135								
Tool Style								
D = Drill								
Handle Configuration								
PV = Pistol Grip (Variable Speed)								
Speed Options (RPM)								
7 = 600								
14 = 1,250								
28 = 2,600								
Generation								
B = Second								
Termination								

- 42 = 1/4" Heavy Duty Capacity Drill Chuck (3/8"-24B spindle)**
- 43 = 3/8" Heavy Duty Capacity Drill Chuck (3/8"-24B spindle)**
- 50 = 1/2" Capacity Drill Chuck (3/8"-24B spindle)**
- 51 = 3/8" Capacity Drill Chuck (3/8"-24B spindle)**
- 40 = No Drill Chuck (3/8"-24B spindle)**

Cleco® Specifications

823040EN

12/10/2015

135 Series Pistol Grip Drill - Variable Speed

Model Number	Free Speed (rpm)	Variable Speed (rpm)	Length		Weight		Compressed Air		Drill Chuck Termination
			in	mm	lbs	kg	Inlet NPT	Hose I.D.	
135DPV-7B-40	600	150 - 550	7.9	201	3.5	1.59	1/4	1/4	No Drill Chuck
135DPV-7B-42	600	150 - 550	9.6	244	3.6	1.63	1/4	1/4	1/4" Capacity Heavy Duty
135DPV-7B-43	600	150 - 550	9.6	244	3.6	1.63	1/4	1/4	3/8" Capacity Heavy Duty
135DPV-7B-50	600	150 - 550	9.6	244	3.6	1.63	1/4	1/4	1/2" Capacity
135DPV-7B-51	600	150 - 550	9.6	244	3.6	1.63	1/4	1/4	3/8" Capacity
135DPV-14B-40	1,250	400 - 1,200	7.6	193	3.3	1.50	1/4	1/4	No Drill Chuck
135DPV-14B-42	1,250	400 - 1,200	9.3	236	3.4	1.54	1/4	1/4	1/4" Capacity Heavy Duty
135DPV-14B-43	1,250	400 - 1,200	9.3	236	3.4	1.54	1/4	1/4	3/8" Capacity Heavy Duty
135DPV-14B-50	1,250	400 - 1,200	9.3	236	3.4	1.54	1/4	1/4	1/2" Capacity
135DPV-14B-51	1,250	400 - 1,200	9.3	236	3.4	1.54	1/4	1/4	3/8" Capacity
135DPV-28B-40	2,600	700 - 2,400	6.8	173	3.1	1.41	1/4	1/4	No Drill Chuck
135DPV-28B-42	2,600	700 - 2,400	8.5	216	3.2	1.45	1/4	1/4	1/4" Capacity Heavy Duty
135DPV-28B-43	2,600	700 - 2,400	8.5	216	3.2	1.45	1/4	1/4	3/8" Capacity Heavy Duty
135DPV-28B-50	2,600	700 - 2,400	8.5	216	3.2	1.45	1/4	1/4	1/2" Capacity
135DPV-28B-51	2,600	700 - 2,400	8.5	216	3.2	1.45	1/4	1/4	3/8" Capacity

USATCO U.S. Air Tool Company, Inc.

Info@usatco.com

Eastern Division60 Fleetwood Ct., Ronkonkoma, NY 11779-6907 tel: (631) 471-3300 fax: (631) 471-3308

Western Division1219 W. Mahalo Place, Rancho Dominguez, CA 90220-5446 tel: (310) 632-5400 fax: (310) 632-3900

The original language of this manual is English.

Product Safety Information:

Intended Use:

This drill shall be used only for removing material by using appropriate drill bits as the cutting tool.

For additional product safety information refer to Apex Tool Group, LLC or Apex Tool Group GmbH & Co. OHG document CE-2006, General Safety Portable Drills.



This drill must not be modified in any manner unless approved in writing by Apex Tool Group, LLC or Apex Tool Group GmbH & Co. OHG. All safety devices must be properly installed and maintained in good working order.

EC Declaration of Conformity:

We affirm that this machine is in accordance with the following EC regulations (2006/42/EC). Applied harmonized standards are ISO 12100:2010-11.

The name, job function and address of the person authorized to compile the technical file.

Mr. Vishnu Irigireddy
 Director of Global R&D- Mechanical Engineering
 Apex Tool Group
 670 Industrial Drive
 Lexington, SC 29072

Signature: Vishnu Irigireddy
 Date: 12/08/2015

Noise and Vibration:

Noise: ≤ 84 dB(A)

Vibration: < 2.5 m/s²

Air Line Lubrication:

Use Apex Tool Group, LLC or Apex Tool Group GmbH & Co. OHG's lightweight air tool oil 500021 (available in quantities shown in the following chart) or an SAE-5 lightweight spindle oil.

Part No.	Packaged	Designation
540397	1 Quart (0.94 liter)	Airlube 10W/NR-420LB DR
533485	1 US Gallon (3.78 liter)	Airlube 10W/NR-420LB DR

Grease:

Application of the screwdriver should determine how frequently it is greased. It is recommended that all gearing receive a generous amount of grease after every 40 hours of operation.

Part No.	Packaged	Designation
540450	18 oz. (0.51 kg)	Black Pearl EP-NLGI-0
540395	2 oz. (0.06 kg)	Magnalube-G
513156	16 oz. (0.45 kg)	Magnalube-G
541444	2 oz. (0.06 kg)	Rheolube 363AX-1
541445	16 oz. (0.45 kg)	Rheolube 363AX-1

The clutch housing and clutch assembly must be removed and the grease applied through the hex in the gear carrier.

Air Supply Line:

Parameter	Description
Air Hose	Minimum inside diameter: 1/4" (6.4 mm) Maximum length: 8' (2.5 m)
Working pressure range	Performance rated at: 90 psi (620 kPa)
Compressed air	Air quality according to ISO 8573-1, quality class 2.4.3 The compressed air must be clean and dry.

Service and Repair:

Tool service and repair should be performed by an authorized Apex Tool Group, LLC or Apex Tool Group GmbH & Co. OHG Center. Refer to the last page of this manual for locations.

Disposal:



Observe local disposal guidelines for all components of this tool and its packaging.

Copyright Protection:

Apex Tool Group, LLC or Apex Tool Group GmbH & Co. OHG reserves the right to modify, supplement or improve this document or the product without prior notice. This document may not be reproduced in any way, shape or form, in full or parts thereof, or copied to another natural or machine readable language or to a data carrier, whether electronic, mechanical, optical or otherwise without the express permission of Apex Tool Group, LLC or Apex Tool Group GmbH & Co. OHG

Operation:

The drill is started by depressing the trigger and is stopped by releasing the trigger.

Speed Adjustment:

Speed adjustment is done by depressing the indexing blade, on the side of the tool, and rotating the speed adjustment cap to the desired RPM setting.

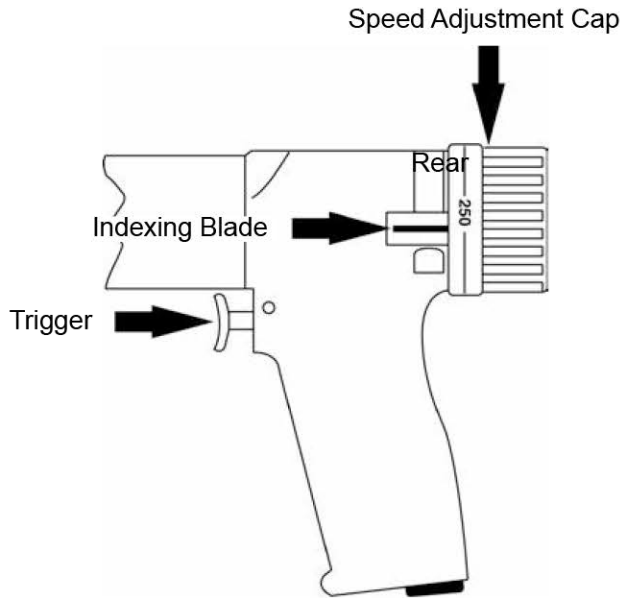

Governor Valve Bushing:

If the governor valve bushing (863993), located in the handle, requires replacement press it out the front of the handle.

Coat the new bushing with Locktite® 271 and press flush with the rear of the handle. **Note: The new bushing must be honed to .6875"/.6880" (17.4625mm/17.4752mm) after being installed.**

Motor Service:

If motor disassembly was necessary, clean all parts in a solvent and inspect for excessive wear or damage. It is recommended that all o-rings and seals be replaced each time the tool is disassembled. Replace as necessary with genuine Cleco replacement parts.

The rotor blades should be replaced every repair cycle or if they measure less than 5/32" (4mm) on either end.

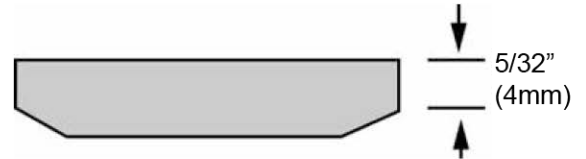

All gears, gear pins, and open bearings should receive a generous amount of grease before reassembly.

Motor Assembly:

To properly set the rotor collar, assemble the rear rotor bearing into the rear bearing plate. Hold the inner race of the bearing forward and measure the depth of the inner race from the face of the bearing plate. Select a rotor collar (or sand) .0015" larger than this dimension.

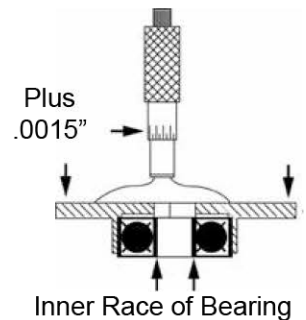

Assemble the collar, rotor bearing, bearing plate and governor assembly (LH Thread) to the rotor. The clearance between the rear bearing plate and rotor should be .001" (.0254mm) after tightening the governor.

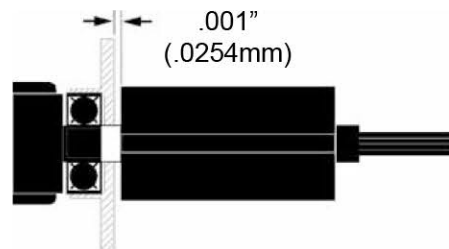

After final assembly, make sure the rotor does not rub the front bearing plate.

Gearing Service:

If replacement of the planetary gear pins is necessary, they should be pressed out the rear of the gear carrier.

Install the new planetary gear pins as shown in the following illustrations.

Single Reduction Gearing (code -28)



Double Reduction Gearing (codes -14, -7)

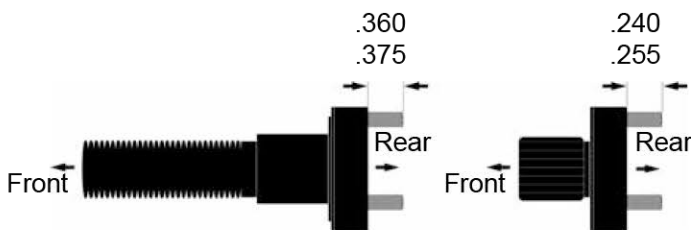

“A”

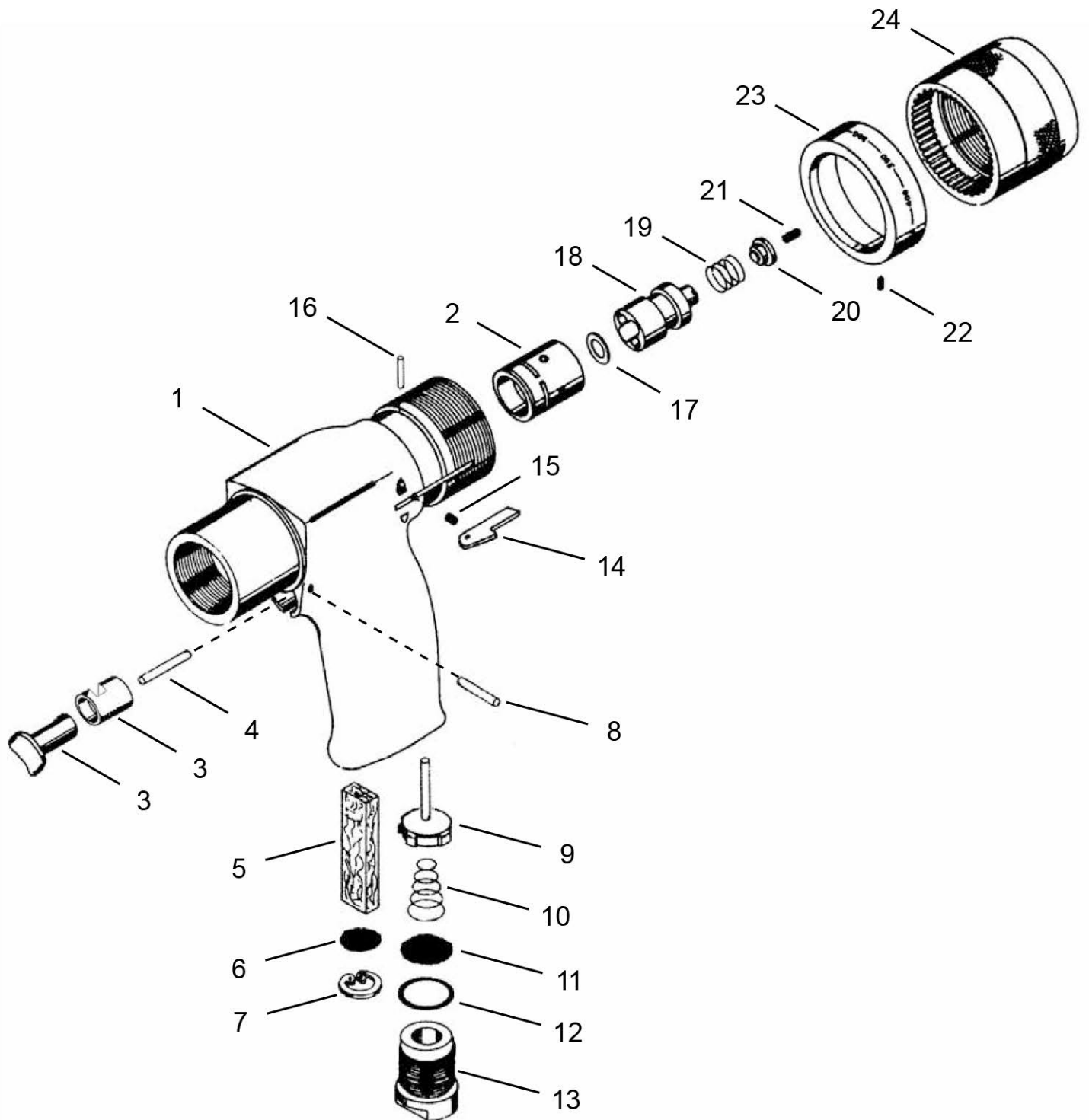

861801 Pistol Grip Handle

Illustration "A": 861801 Pistol Grip Handle Assembly

Ref	Number	#	X	EN
				Description
--	861801	1		Handle Assembly (includes Ref. 1-16)
1	869611	1		Pistol Grip Handle Assembly (includes Ref. 2)
2	863993	1		Governor Valve Bushing
3	201905	1		Trigger Assembly
4	203616	1	1	Throttle Link Pin
5	869581	1	3	Muffler
6	833303	1	3	Muffler Screen
7	847033	1	1	Retaining Ring
8	832638	1	1	Trigger Pin
9	203617	1		Throttle Valve
10	869582	1	3	Throttle Valve Spring
11	412775	1	3	Air Inlet Screen
12	847411	1	3	O-Ring (11/16" x 13/16")
13	867916PT	1		Air Inlet Bushing
14	863995	1		Indexing Blade
15	842652	1	3	Indexing Blade Spring
16	864185	1	1	Indexing Blade Pin
17	863992	1		Governor Spacer (.005")
	864505	1		Governor Spacer (.007")
	864506	1		Governor Spacer (.020")
18	863991	1		Governor Valve
19	863994	1	3	Governor Spring
20	864584	1		Auxiliary Spring Cap
21	847806	1	3	Auxiliary Governor Spring
22	864193	1	3	Rotational Stop Set Screw
23	869603	1		Speed Indicating Ring (135DPV-7B series)
	869604	1		Speed Indicating Ring (135DPV-14B series)
	869746	1		Speed Indicating Ring (135DPV-28B series)
24	863987	1		Speed Adjusting Cap

(#) Quantity

(X) Recommended Spare Parts (quantity shown based on 1-5 tools in operation)

“B”

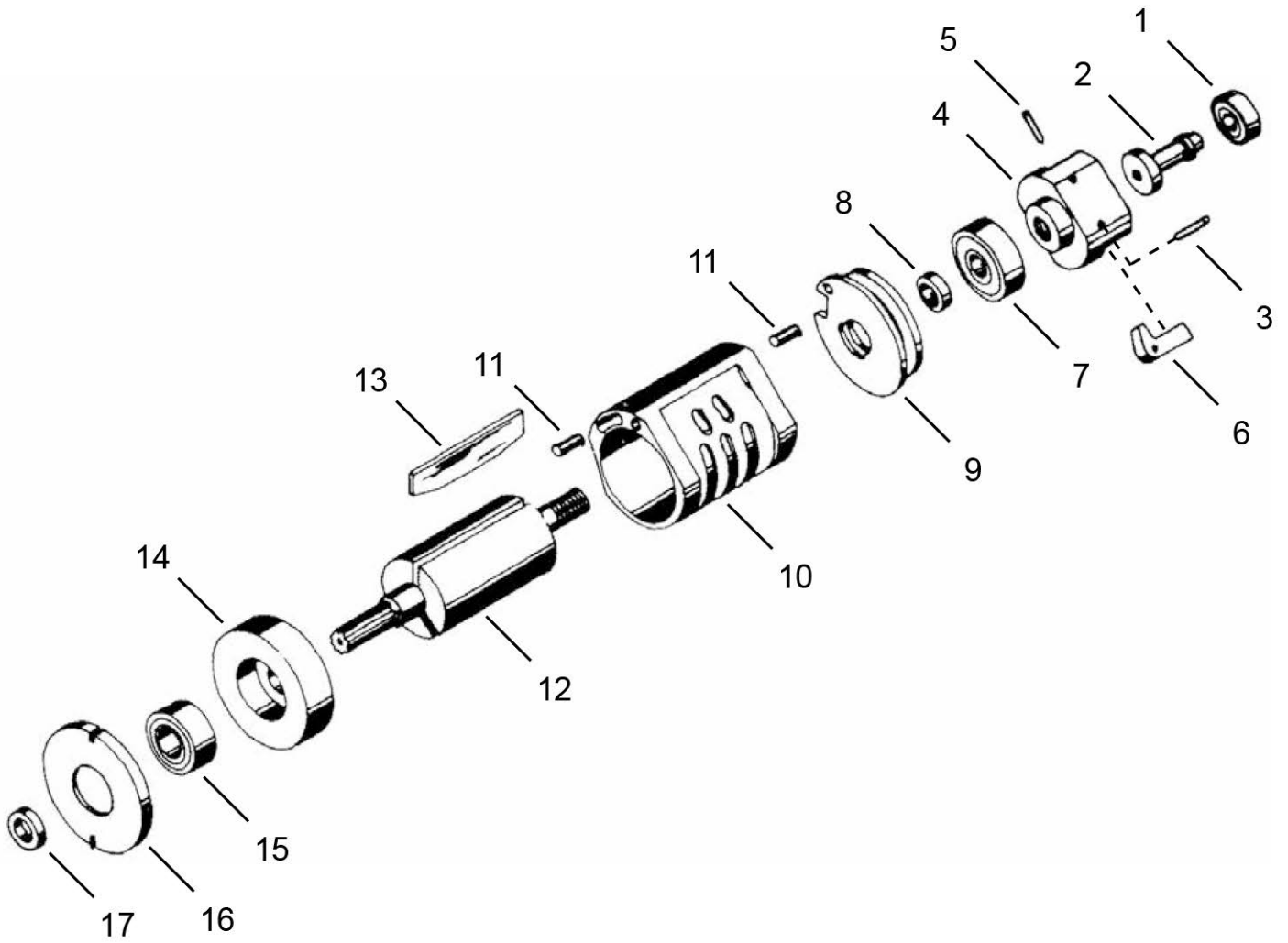

Illustration "B": Motor Assembly

Ref	Number	#	X	EN
				Description
1	842768	1	2	Governor Center Bearing
2	863983	1		Governor Center
3	833859	2	2	Governor Weight Pin
4	865587	1		Governor Body
5	843871	1	2	Governor Center Stop Pin
6	863984	2		Governor Weight
7	843446	1	2	Rear Rotor Bearing
8	864196	1		Rotor Collar
9	863986	1		Rear Bearing Plate
10	869451	1		Cylinder (includes Ref. 11)
11	812165	2	2	Cylinder Pin
12	869607	1		Rotor
13	869788	3	9	Rotor Blade
14	869720	1		Front Bearing Plate
15	847511	1	2	Front Rotor Bearing
16	202279	1		Motor Spacer
17	869584	1		Pinion Spacer (135DPV-14B series only)

(#) Quantity

(X) Recommended Spare Parts (quantity shown based on 1-5 tools in operation)

“C”

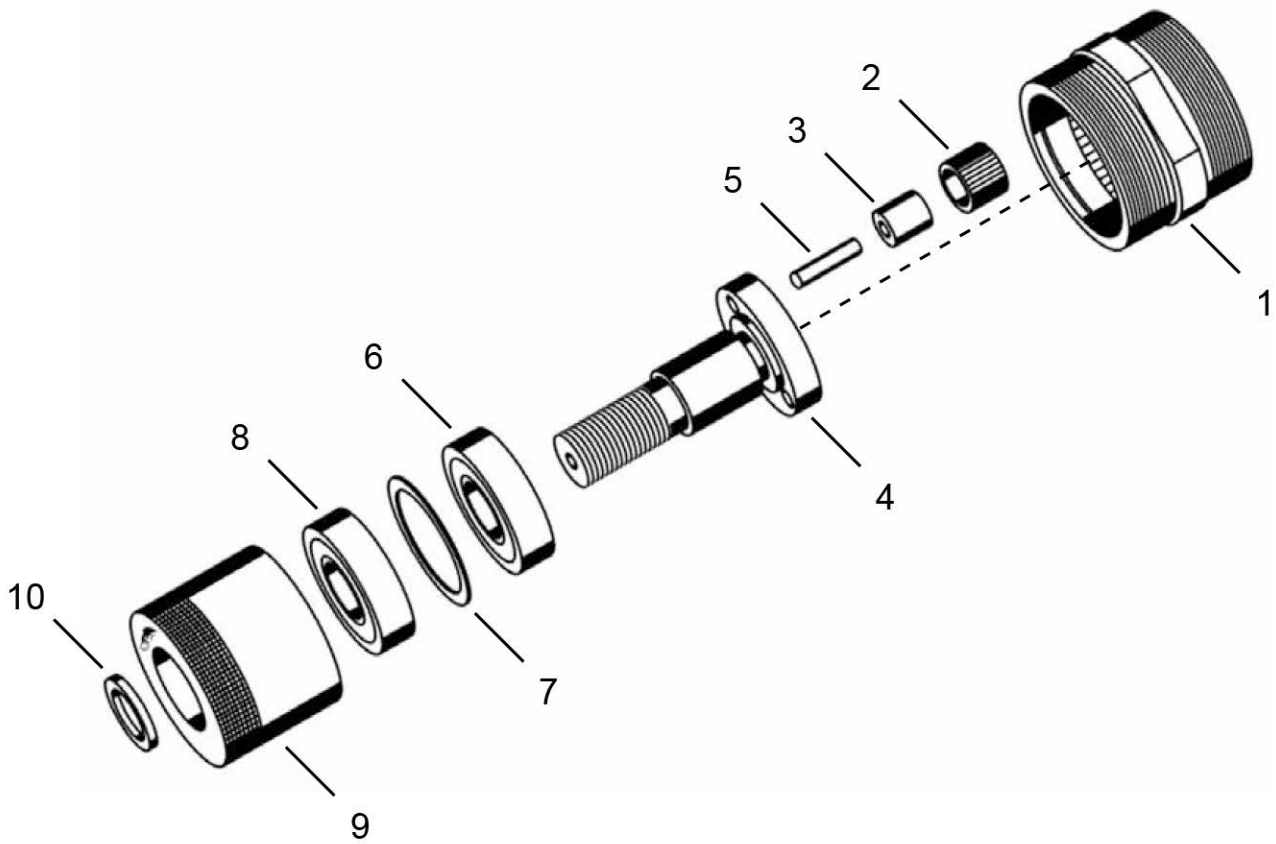

861957 Single Stage Gearing (Code -28)

Illustration "C": 861957 Gearing Assembly

Ref	Number	#	X	EN
				Description
--	861957	1		Gearing Assembly (speed code -28)
1	867871	1		Gear Case
2	867866	3	6	Planetary Gear (18T) (includes Ref. 3)
3	867921	3	6	Planetary Gear Bearing
4	202033PT	1		Planetary Carrier Output Spindle (includes Ref. 5)
5	867922	3	6	Planetary Gear Pin
6	843635	1	2	Rear Spindle Bearing
7	867714	1	2	Shim
8	202032PT	1	2	Front Spindle Bearing
9	202031	1		Bearing Retainer
10	869552	1	1	Drill Chuck Spacer

(#) Quantity

(X) Recommended Spare Parts (quantity shown based on 1-5 tools in operation)

(T) Teeth

USATCO U.S. Air Tool Company, Inc.

Info@usatco.com

Eastern Division60 Fleetwood Ct., Ronkonkoma, NY 11779-6907 tel: (631) 471-3300 fax: (631) 471-3308

Western Division1219 W. Mahalo Place, Rancho Dominguez, CA 90220-5446 tel: (310) 632-5400 fax: (310) 632-3900

“D”

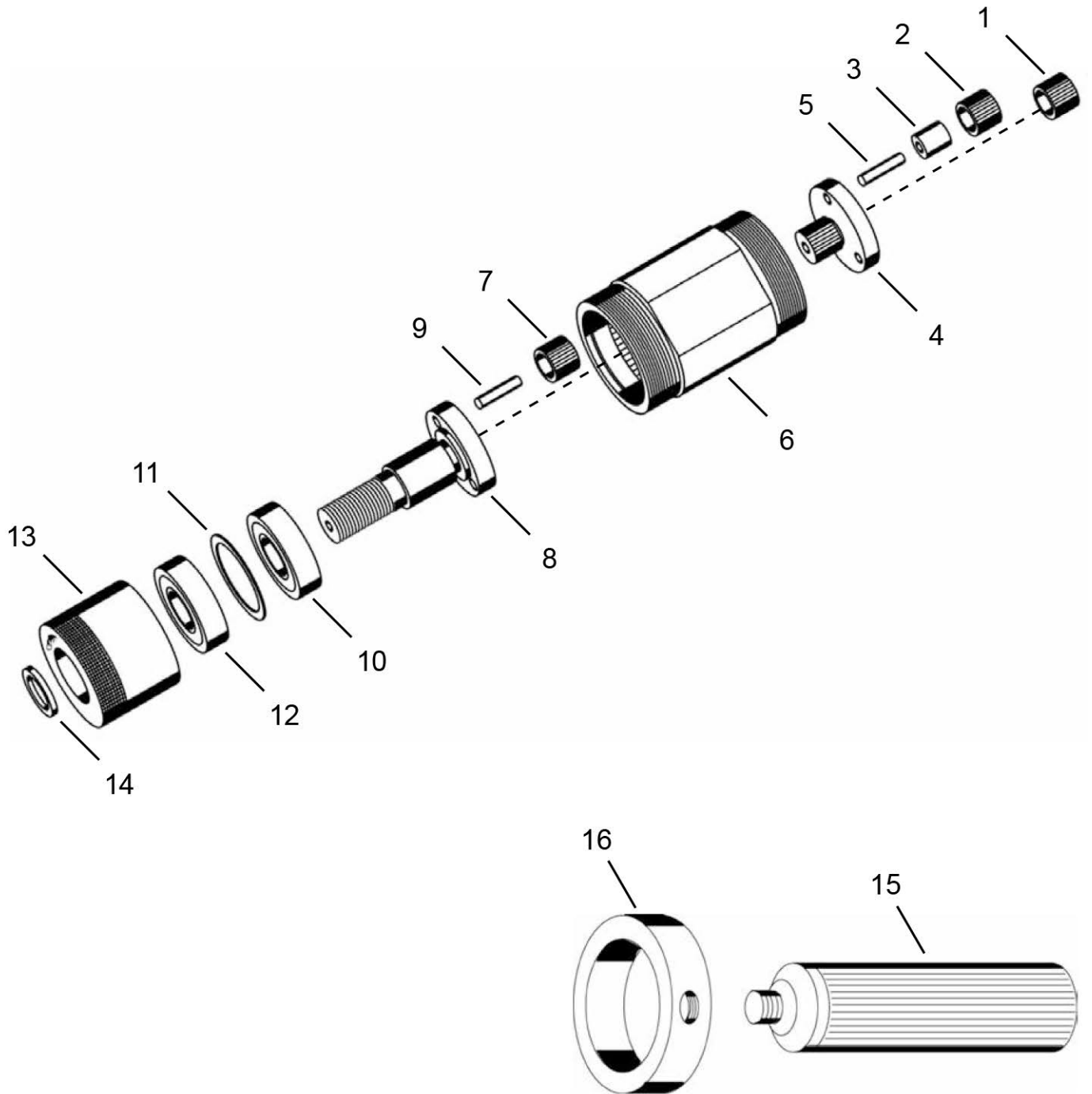

861956 Double Stage Gearing (Code -14)

Illustration "D": 861956 Gearing Assembly

Ref	Number	#	X	EN
				Description
--	861956	1		Gearing Assembly (speed code -14)
1	867902	1	2	Pinion Gear (15T)
2	867903	3	6	Planetary Gear (15T) (includes Ref. 3)
3	867925	3	6	Planetary Gear Bushing
4	867905	1		Planetary Carrier (includes Ref. 5)
5	884125	3	6	Planetary Gear Pin
6	867907	1		Gear Case
7	867904	3	6	Planetary Gear (15T)
8	202038PT	1		Planetary Carrier Output Spindle (includes Ref. 9)
9	832128	3	6	Planetary Gear Pin
10	843635	1	2	Rear Spindle Bearing
11	867714	1	2	Shim
12	202032PT	1	2	Front Spindle Bearing
13	202031	1		Bearing Retainer
14	869552	1	1	Drill Chuck Spacer
--	861006PT	1		Support Handle Assembly (includes Ref. 15-16) (Termination code -50 models)
15	881393	1		Support Handle
16	869304	1		Support Handle Ring

(#) Quantity

(X) Recommended Spare Parts (quantity shown based on 1-5 tools in operation)

(T) Teeth

“E”

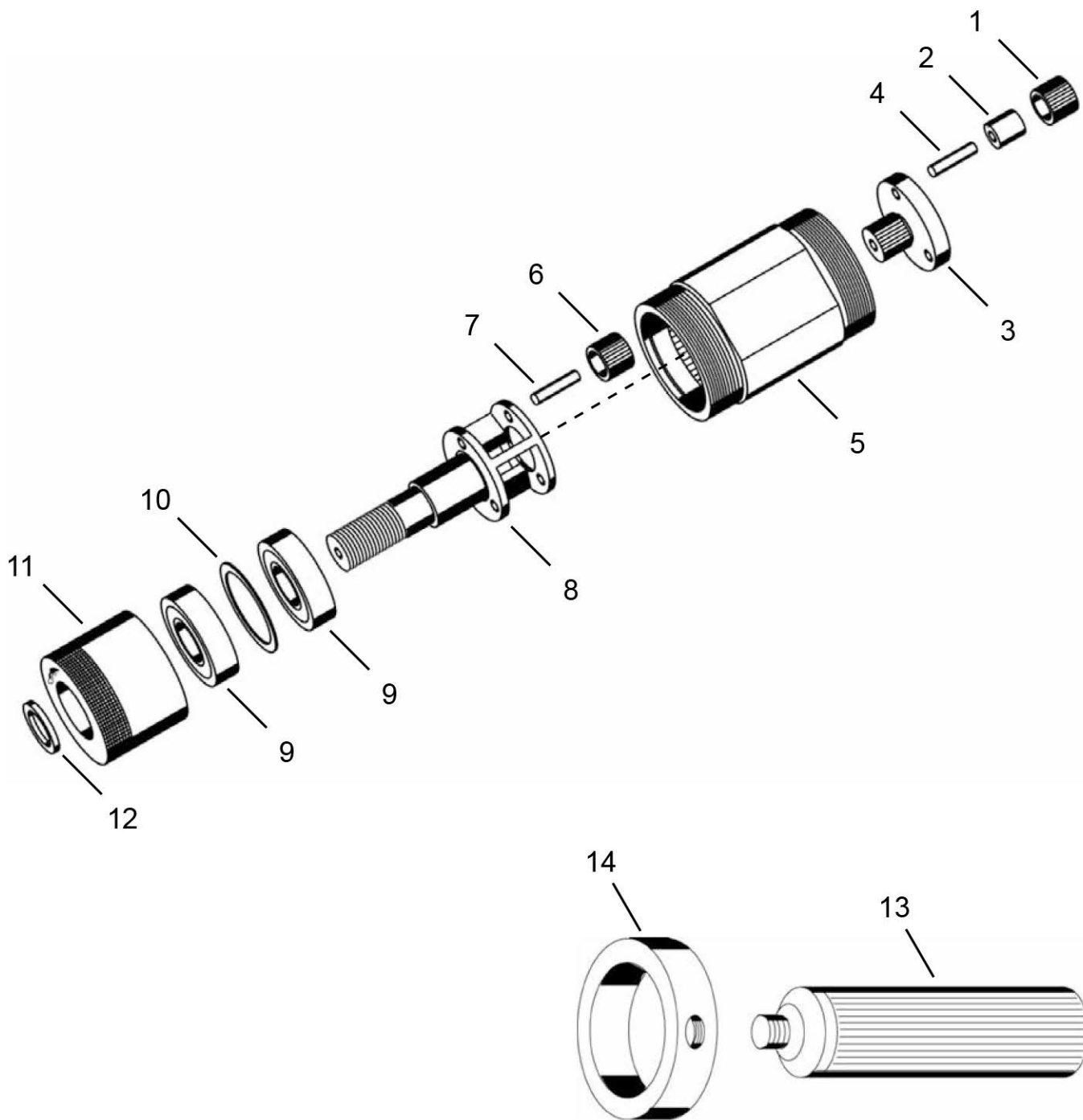

861954 Double Stage Gearing (Code -7)

Illustration "E": 861954 Gearing Assembly

Ref	Number	#	X	EN
				Description
--	861954	1		Gearing Assembly (speed code -7)
1	869254	3	6	Planetary Gear (19T) (includes Ref. 2)
2	867921	3	6	Planetary Gear Bearing
3	869256	1		Planetary Carrier (includes Ref. 4)
4	867922	3	6	Planetary Gear Pin
5	867907	1		Gear Case
6	869255	3	6	Planetary Gear (15T)
7	842728	3	6	Planetary Gear Pin
8	202037	1		Planetary Cage Output Spindle
9	202032PT	2	4	Output Spindle Bearing
10	867714	1	2	Shim
11	202031	1		Bearing Retainer
12	869552	1	1	Drill Chuck Spacer
--	861006PT	1		Support Handle Assembly (includes Ref. 13-14) (Termination code -50 models)
13	881393	1		Support Handle
14	869304	1		Support Handle Ring

(#) Quantity

(X) Recommended Spare Parts (quantity shown based on 1-5 tools in operation)

(T) Teeth

USATCO U.S. Air Tool Company, Inc.

Info@usatco.com

Eastern Division60 Fleetwood Ct., Ronkonkoma, NY 11779-6907 tel: (631) 471-3300 fax: (631) 471-3308

Western Division1219 W. Mahalo Place, Rancho Dominguez, CA 90220-5446 tel: (310) 632-5400 fax: (310) 632-3900

Cleco®

Drill Chuck Terminations

“F”**Termination -42:
1/4” Heavy Duty Drill Chuck****“G”****Termination -43:
3/8” Heavy Duty Drill Chuck****“H”****Termination -50:
1/2” Capacity Drill Chuck****“I”****Termination -51:
3/8” Capacity Drill Chuck**

Illustration "F": Termination -42: 1/4" Heavy Duty Capacity Drill Chuck

Ref	Number	#	X	EN
				Description
1	202058	1		Drill Chuck Guard
2	849106PT	1		Drill Chuck (1/4" Capacity)
3	849118	1	1	Drill Chuck Key

Illustration "G": Termination -43: 3/8" Heavy Duty Capacity Drill Chuck

Ref	Number	#	X	EN
				Description
1	849103	1		Drill Chuck (3/8" Capacity)
2	849123	1	1	Drill Chuck Key

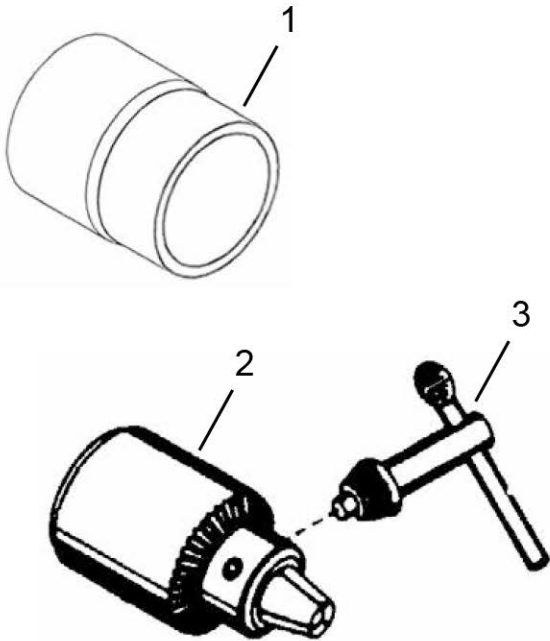
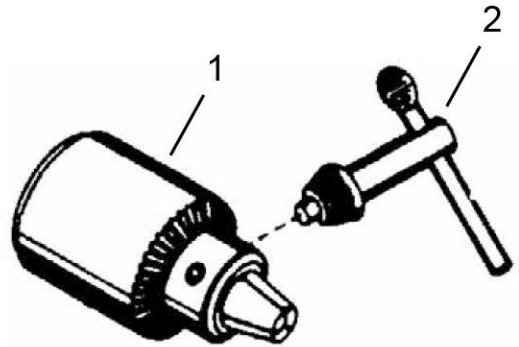
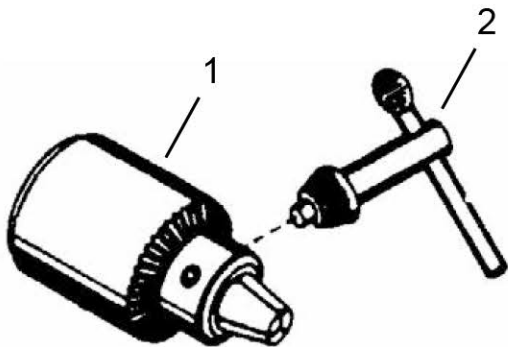
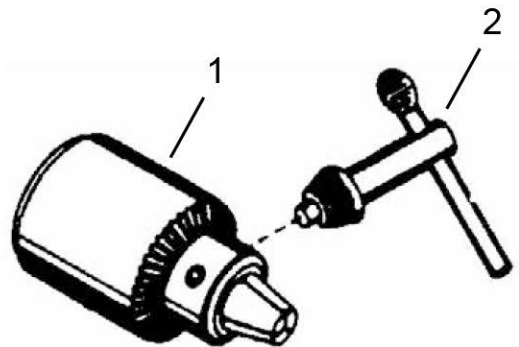
Illustration "H": Termination -50: 1/2" Capacity Drill Chuck

Ref	Number	#	X	EN
				Description
1	889335	1		Drill Chuck (1/2" Capacity)
2	849121	1	1	Drill Chuck Key

Illustration "I": Termination -51: 3/8" Capacity Drill Chuck

Ref	Number	#	X	EN
				Description
1	849108	1		Drill Chuck (3/8" Capacity)
2	849120PT	1	1	Drill Chuck Key

(#) Quantity

(X) Recommended Spare Parts (quantity shown based on 1-5 tools in operation)

POWER TOOLS SALES & SERVICE CENTERS

Please note that all locations may not service all products.
Contact the nearest Apex Tool Group Sales & Service Center for the appropriate facility
to handle your service requirements.

NORTH AMERICA | SOUTH AMERICA

Detroit, Michigan

Apex Tool Group
2630 Superior Court
Auburn Hills, MI 48236
Phone: +1 (248) 393-5640
Fax: +1 (248) 391-6295

Lexington, South Carolina

Apex Tool Group
670 Industrial Drive
Lexington, SC 29072
Phone: +1 (800) 845-5629
Phone: +1 (919) 387-0099
Fax: +1 (803) 358-7681

Louisville, Kentucky

Apex Tool Group
1000 Glengarry Drive
Suite 150
Fairdale, KY 40118
Phone: +1 (502) 708-3400
apexpowertools.com/service

Canada

Apex Tool Canada, Ltd.
7631 Bath Road
Mississauga, Ontario L4T 3T1
Canada
Phone: (866) 691-6212
Fax: (905) 673-4400

Mexico

Apex Tool Group
Manufacturing México
S. de R.L. de C.V.
Vialidad El Pueblito #103
Parque Industrial Querétaro
Querétaro, QRO 76220
Mexico
Phone: +52 (442) 211 3800
Fax: +52 (800) 685 5560

Brazil

Apex Tool Group
Ind. Com. Ferram, Ltda.
Av. Liberdade, 4055
Zona Industrial Iporanga
Sorocaba, São Paulo
CEP# 18087-170
Brazil
Phone: +55 15 3238 3820
Fax: +55 15 3238 3938

EUROPE | MIDDLE EAST | AFRICA

England

Apex Tool Group
GmbH & Co. OHG
C/O Spline Gauges
Piccadilly, Tamworth
Staffordshire B78 2ER
United Kingdom
Phone: +44 1827 8727 71
Fax: +44 1827 8741 28

France

Apex Tool Group S.A.S.
25 rue Maurice Chevalier
B.P. 28
77831 Ozoir-La-Ferrière
Cedex, France
Phone: +33 1 64 43 22 00
Fax: +33 1 64 43 17 17

Germany

Apex Tool Group
GmbH & Co. OHG
Industriestraße 1
73463 Westhausen
Germany
Phone: +49 (0) 73 63 81 0
Fax: +49 (0) 73 63 81 222

Hungary

Apex Tool Group
Hungária Kft.
Platánfa u. 2
9027 Győr
Hungary
Phone: +36 96 66 1383
Fax: +36 96 66 1135

ASIA PACIFIC

Australia

Apex Tool Group
519 Nurigong Street, Albury
NSW 2640
Australia
Phone: +61 2 6058 0300

China

Apex Power Tool Trading
(Shanghai) Co., Ltd
Building A8, No. 38
Dongsheng Road
Pudong, Shanghai
China 201201
Phone: +86 21 60880320
Fax: +86 21 60880298

India

Apex Power Tools India
Private Limited
Gala No. 1, Plot No. 5
S. No. 234, 235 & 245
Indialand Global
Industrial Park
Taluka-Mulsi, Phase I
Hinjawadi, Pune 411057
Maharashtra, India
Phone: +91 020 66761111

Japan

Apex Tool Group Japan
Korin-Kaikan 5F,
3-6-23 Shibakoen, Minato-Ku,
Tokyo 105-0011, JAPAN
Phone: +81-3-6450-1840
Fax: +81-3-6450-1841

Korea

Apex Tool Group Korea
#1503, Hibrand Living Bldg.,
215 Yangjae-dong,
Seocho-gu, Seoul 137-924,
Korea
Phone: +82-2-2155-0250
Fax: +82-2-2155-0252

Apex Tool Group, LLC

1000 Lufkin Road
Apex, NC 27539
Phone: +1 (919) 387-0099
Fax: +1 (919) 387-2614
www.apexpowertools.com

Cleco®