

ORIGINAL INSTRUCTIONS

 **Instruction Manual** **CE**
Pass on to user to read and keep for reference

G784

**DOUBLE ACTION CHERRYLOCK®
POWER TOOL**



AEROSPACE

G784 HYDRO-SHIFT INSTRUCTIONS

TABLE OF CONTENTS

Description 2

Specifications for G784 2

Safety Warnings 2

Putting the tool in service 3

How to Use the G784 3

Pulling Pulling-Heads 3

Tool Capacity chart 4

 Standard CherryLOCK® (NAS1398 & 1399) 4

 Bulb CherryLOCK® (NAS1738 & 1739)..... 4

 Other Fastener Types, Adaptors 4

Maintenance and Repair / Fluid Safety Data 5

Fill and Bleed Instructions 5

Tool Overhaul 6

 Air Valve 6

 Head Sub-Assembly 7

 Handle Sub-Assembly 7

Cross Section Drawing 8

Parts List 9

Exploded View 10

Troubleshooting 11

Set-up and Adjustments 11

Declaration of Conformity Back Cover

WARRANTY

Seller warrants the goods conform to applicable specifications and drawings and will be manufactured and inspected according to generally accepted practices of companies manufacturing industrial or aerospace fasteners. In the event of any breach of the foregoing warranty, Buyer's sole remedy shall be to return defective goods (after receiving authorization from Seller) for replacement or refund of the purchase price, at the Seller's option. Seller agrees to any freight costs in connection with the return of any defective goods, but any costs relating to removal of the defective or nonconforming goods or installation of replacement goods shall be Buyer's responsibility. SELLER'S WARRANTY DOES NOT APPLY WHEN ANY PHYSICAL OR CHEMICAL CHANGE IN THE FORM OF THE PRODUCT IS MADE BY BUYER.

THE FOREGOING EXPRESS WARRANTY AND REMEDY ARE EXCLUSIVE AND ARE IN LIEU OF ALL OTHER WARRANTIES AND REMEDIES; ANY IMPLIED WARRANTY AS TO QUALITY, FITNESS FOR PURPOSE, OR MERCHANTABILITY IS HEREBY SPECIFICALLY DISCLAIMED AND EXCLUDED BY SELLER. THIS WARRANTY IS VOID IF SELLER IS NOT NOTIFIED IN WRITING OF ANY REJECTION OF THE GOODS WITHIN ONE (1) YEAR AFTER INITIAL USE BY BUYER OF ANY POWER RIVETER OR NINETY (90) DAYS AFTER INITIAL USE OF ANY OTHER PRODUCT.

Seller shall not be liable under any circumstances for incidental, special or consequential damages arising in whole or in part from any breach by Seller, AND SUCH INCIDENTAL, SPECIAL, OR CONSEQUENTIAL DAMAGES ARE HEREBY EXPRESSLY EXCLUDED.

For more information please contact our Technical Services Department at Tel. 714-850-6154

*LOCTITE® is a registered trademark of Henkel Corporation
DEXRON® is a registered trademark of GM corporation.
PARKER® is a trademark of Parker Hannifin Corporation
LUBRRIPLATE® is a trademark of Fiske Brothers Refining Co.*

THE G784 HYDRO-SHIFT RIVETER

DESCRIPTION

The Cherry® G784 hydro-shift riveter is designed specifically for installing the standard (double action) CherryLOCK® Rivets.

It will install nearly all diameters of CherryLOCK® Rivets up to a half-inch grip, "A" group only. This powerful tool has been designed with many ergonomic features: low weight, low recoil, low noise and a comfortable fit in the operator's hand.

With proper adapters and pulling heads this tool can be used to install other types of rivets.

SPECIFICATIONS FOR G784

CHERRY® Aerospace (CHERRY®) policy is one of continuous development. Specifications shown in this document may be subject to change which may be introduced after publication.

For the latest information always consult CHERRY®.

AIR PRESSURE	90 to 110 psi (6,2 bar to 7,6 bar)
STROKE	7/8 inch (22,2 mm)
PULLING FORCE	2,600 lbs. (11,57 kN) @ 90 PSI (6,2 bar),
WEIGHT	8 lbs. (3,63 kg)
NOISE LEVEL	69.7 dB (A)
VIBRATION	less than 2,5 m/s ²
AIR CONSUMPTION	0.27 SCF/cycle (7,65 L/cycle)

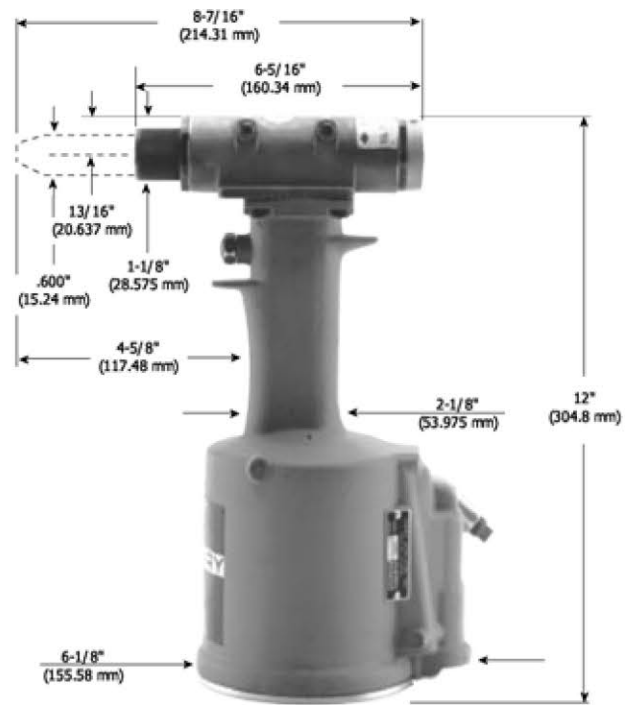

PUTTING THE TOOL IN SERVICE

The tool should be used with a regulated air-line; do not exceed the pressure posted on the tool label.

If necessary, the Cherry in-line pressure regulator P1505 is available for purchase.

Pressure Regulator (P1505), may be attached to any shop airline.

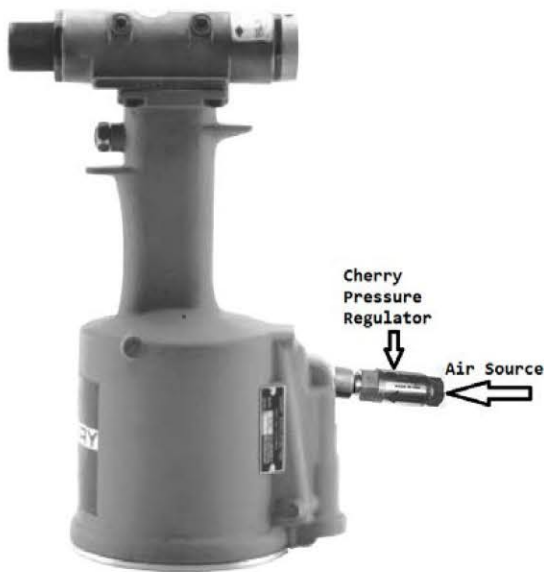

Connect the tool to a pressure regulated air-line.

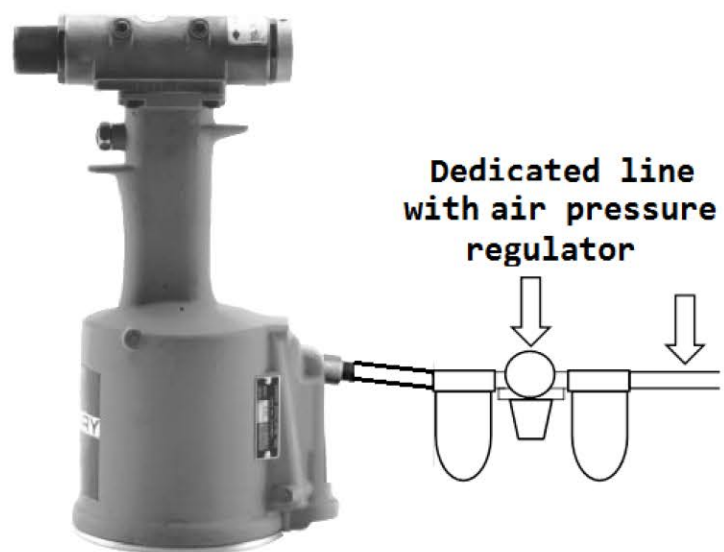

GENERAL SAFETY WARNINGS

General Safety Rules

- Read and understand the safety instructions before installing, operating, repairing, maintaining, changing accessories on or working near this equipment. Failure to do so can result in serious bodily injury
- Only qualified and trained operators should install, adjust or use this tool and its accessories
- Do not modify this tool; modifications can reduce the effectiveness and compromise safety, increasing the risk to the operator
- Only use genuine Cherry components; use of unauthorized substitutions compromises the tool safety and void warranty. The consequences shall be at the customer's entire responsibility.
- Do not discard the safety instructions; distribute them to the operators using this equipment
- Inspect the tool periodically to verify that is in good working condition and all the information is legibly marked. Contact Cherry Aerospace to obtain replacement new markings if necessary
- Do not use this equipment if it has been damaged.

Projectile hazards

- Unless otherwise specified, disconnect the equipment from the power source when servicing or changing accessories
- Be aware that failure of the workpiece or of this equipment can generate high velocity projectiles. Always wear impact resistant eye protection when operating the tool. The grade of protection required should be assessed for each use.
 - The risks to others should also be considered; never pull rivet in the air or directed at any person
- Ensure that the workpiece into which the fasteners are installed is securely fixed and properly aligned and prepared
- Check that the means of protection from ejection of spent stems is in place and it is in good operating condition.
- Warn against the possible forcible front ejection when pulling fasteners in the air or when using front ejecting attachments.

Operating Hazards

- Use of tools can expose the operator's hands to hazards including crushing, impacts, cuts abrasion and chemical exposure from the internal hydraulic fluid. Use caution when operating this equipment and wear suitable gloves.
- Make sure that the operators and maintenance personnel are physically able to handle the bulk, weight and operating forces of this equipment. Instruct the operator on how the tool is correctly held and operated; be read to counteract the normal or sudden movements of this equipment and have both hands available.
- Maintain a balanced body position and secure footing
- Release the trigger button in case of interruption of the energy supply.
- Use only the transmission fluid and lubricants recommended by Cherry
- Avoid uncomfortable postures as these positions will not allow properly counteracting the operating forces of this tool
- If this tool is operated in a fixed position, make sure that the fixation device is properly secured.
- Beware of the risk of pinching or crushing if pulling head or adaptors are not mounted on this equipment

Repetitive Motions Hazards

- When using this tool, the operator may experience discomfort in the hands, arms, shoulders, neck or other parts of the body.
- While using this equipment the operator should adopt a comfortable posture whilst maintaining a secure footing and avoiding awkward or off-balance postures. Change posture frequently during extended tasks to help avoid discomfort and fatigue
- If the operator experiences symptoms such as persistent or recurring discomfort, pain, throbbing, aching, tingling or numbness, these symptoms should not be ignored. Make sure the proper safety measures are taken and the operator comfort is properly assessed during the operation of this equipment.

Accessory Hazards

- Unless otherwise specified, disconnect from the air source before changing accessories or otherwise servicing this equipment
- Use only the sizes and types of tools and accessories recommended by Cherry to work with this equipment.

Workplace Hazards

- Slips, trips and falls are major causes of workplace injury. Be aware of slippery surfaces around the area this equipment is in operation, fallen spent stems, and trip hazards created by the connecting air supply hose.
- Proceed with caution when in unfamiliar surroundings; there can be hidden hazards such as electricity and other utility lines
- This equipment has not been tested for use in potentially flammable or explosive environments; use caution when contact with electric power is possible as this tool has a metallic construction that has not fully insulated and tested against electric contact.
- Ensure that there are not electric cables, gas pipes, etc. which can cause a hazard if damaged by the use of this equipment.

Noise Hazards

- This tool meets the regulatory requirements for noise hazards; however, long exposure to noise can cause permanent, disabling hearing loss or tinnitus (ringing, buzzing in the ears). Use proper ear protection to minimize exposure to noise
- Appropriate controls should be taken when fixturing the workpiece to reduce noise amplification by "ringing" or impact shock; such controls may involve vibration dampening materials and methods.
- Make sure that the equipment is in proper working condition to avoid unnecessary increase in noise.

Vibration Hazards

- This tool meets the regulatory requirements for vibration; however, long exposure to the tool operating forces and especially if used in an uncomfortable posture can cause permanent, disabling damage to nerves and blood supply to hands and arms.
- Wear warm clothing when working in cold conditions and keep your hands warm and dry
- If you experience numbness, tingling, pain or whitening of the skin on your fingers or hands tell your employer and consult a physician.

Additional safety instructions:

- Pressurized air can cause severe injury:
 - Always shut-off or disconnect from the air supply when tool not in used or when servicing the equipment
 - Never direct air exhaust or direct air jet to yourself or anyone else
- Whipping hoses can cause severe injury; always check for damaged or loose hoses, valves and fittings
- Cold pressurized air shall be directed away from anyone's hands or body
- Do not exceed the recommended maximum operating air pressure; if a regulated airline is not available, the Cherry in-line pre-set air pressure regulator P/N P1505 may be used.
- Never hold or carry this equipment by the hose;
- Avoid dropping this tool on hard surfaces; do not pound on the rear of the tool head to force rivets into holes.

OPERATING INSTRUCTIONS

Before using the tool:



- Read the tool manual and especially the safety instructions before first using the tool.
- Make sure that the riveter is properly set (see below) and in good working condition.
- Select the correct pulling head for the fastener to be installed
- Keep the pulling head clean, especially around the front end as debris or dried sealant will cause major installation issues.

TOOL SET-UP AND ADJUSTMENTS

SHIFT POINT SETTING

This adjustment adjusts the flushness of break of the rivet stem.

Before adjusting, make sure to remove the Pulling Head and the Sleeve Cap; also connect tool to a power supply. Use setting gage 680A159 (included) to make adjustments as described below:

1. Screw the small end of 680A159 gage onto head piston (16) until hand-tight.
2. Depress and hold trigger; observe the final position of the gage; Gage Point A should be flush with the front of the tool head as shown below in the right. Release trigger.

Warning: This tool cannot be set to points B and C

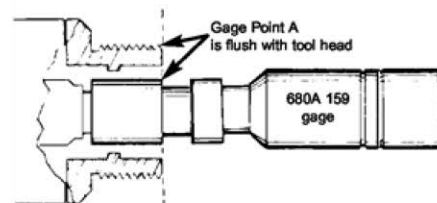
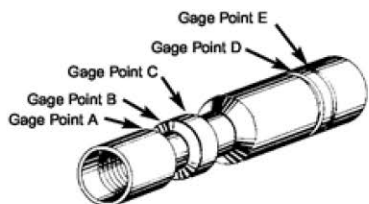

To make finite adjustments, turn the adjuster knob (39):

- Clockwise to increase gage protrusion (lower stem break)
- Counterclockwise to decrease gage protrusion (higher stem break).
- Cycle the tool after each adjustment and check the gage point; the adjustment is limited by the construction of the tool to 1/2 turn from the initial position.

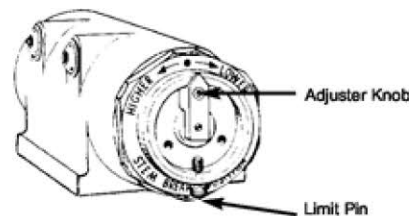

SHIFT PISTON CHECK

- Use this procedure to make sure that the shift piston functions properly.
- Push the large (unthreaded) end of 680A159 gage over the head piston (16) until seating it inside of the riveter as shown in the schematic in the right. The front of the tool must align with the gage point D.
- Depress the trigger, while pushing the gauge onto the piston; at the end of the cycle, the gage should be pushed out, aligning point E to the front of the tool.

If the Shift Piston does not gauge correctly, it may be an indication of lack of fluid; bleed the system per page 5 and gauge again. If this does not fix it, service/repair must be conducted.

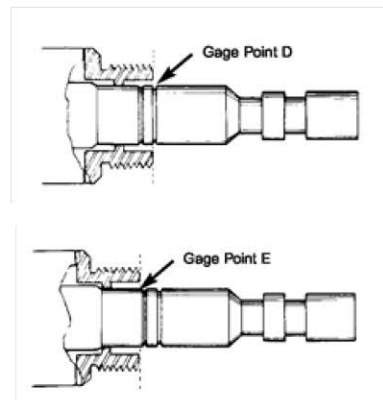

HOW TO USE THE G784

- Select the proper pulling head for the diameter and type of fastener to be installed and attach it securely to the tool (see table below).
- Insert the rivet into the prepared hole in the structure.
- Push the pulling head onto the rivet stem, pushing the tool forward the front of the tool contacts the head of the rivet.
- While keeping the tool coaxial with the fastener, activate the trigger;
- Eject the broken stem via the front of the tool upon release of the trigger.

Standard Wiredraw CherryLOCK® Rivets (NAS1398 & NAS1399)

Rivet Dia.	Tool P/N	Aluminum & Monel		Stainless Steel		Tool P/N	Aluminum & Monel	Stainless Steel
		CR2163	CR2162	CR2643	CR2642		CR2164	CR2644
		CR2263	CR2262	CR2653	CR2652		CR2564	CR2664
		CR2563	CR2562	CR2663	CR2662		(NAS1097)	(NAS1097)
		Univ. Head	Flush Head	Univ. Head	Flush Head		Flush Head	Flush Head
-3	H681-3C	-	-	All Grips	All Grips	-	-	-
-4	H681-4C	All Grips	All Grips	All Grips	All Grips	H681-4S	All Grips	All Grips
-5	H681-5C	up to -08	up to -09	up to -08	up to -09	H681-5S	up to -09	up to -09
-6	H681-6C	up to -08	up to -09	up to -08	up to -09	H681-6S	up to -09	-
-8	H681-8C	up to -08	up to -09	-	-	H681-8S	up to -09	-

Bulb Type CherryLOCK® Rivets (NAS1738 & NAS1399)

Rivet Dia.	Tool P/N	-	CR2238	Tool P/N	CR2540	Tool P/N	CR2235
		CR2249	CR2248				CR2245
		CR2539	CR2538				CR2545
		CR2839	CR2838				CR2845
		Univ. Head	Flush Head				Unisink
-4	H681-4C	All Grips	All Grips	H681-4F	All Grips	H681B166-4	All Grips
-5	H681-5C	All Grips	All Grips	H681-5F	All Grips	H681B166-5	All Grips
-6	H681-6C	All Grips	All Grips	H681-6F	All Grips	H681B166-6	All Grips



RIVETER REPAIR AND MAINTENANCE

Tool must be serviced in case of malfunction, massive fluid loss or as part of your routine maintenance program.

Tools and Service Kits Needed

- Make sure that the proper service kit (*ordered separately*) and tools are available.
 - **G784KT – tool kit, Needle Nose Pliers,**
 - **G784KS – service kit:**

**836B740
Valve Spring Installation
Tool**



**700B65
Packing Plug Wrench**



**680A173
Socket Wrench**



**837B740
Valve Sleeve Removal
Tool**

**700A61
Piston Rod
Wrench**



**740A43
Power Cylinder Tool**



**680A48/49
Clamp Wrench**



**740A43
Shift Piston Tool**

**700A60
Seal Guide**



**700A77
Air Bleeder**



**680A114
Seal Guide**

G784KT TOOL KIT

SERVICE PROCEDURE

AIR VALVE SUB-ASSEMBLY

Disassembly Instructions:

- Remove Retaining Ring (58) and Muffler (57).
- Pull the Valve Plug (56) and Spool Assembly (50) out with the help of tool P1178;
- If necessary, pull the Valve Sleeve (47) with tool 837B740 after dislodging the spring (48) with a needle-nose pliers and pulling it out.

Assembly Instructions:

- Reverse the above procedures. Use Install tool 836B740 to push and snap the Spring (48) into its groove.

HEAD SUB-ASSEMBLY**Disassembly:**

- Remove Head Cylinder subassembly from the Handle by removing the four cap screws used to tighten it.
- Remove cap screws and Stat-O-Seals (8 & 9) and drain the hydraulic fluid according to environmental regulations.
- Place the Head Cylinder (7) in a vise vertically with the Front-end Cap (3) upwards;
- Remove the Front-end Cap (3) with socket wrench 680A173; remove the Piston Stops (11).
- Turn the Head Cylinder in the vise so that the Rear-end Cap (33) is upwards; remove the Screws and the Plastic Adjuster Knob (38 & 39) with a 3/32 hex key. Remove the adjuster ring (40).
- Remove the Rear-end Cap (33); push the head piston (16) towards the rear to remove the Shift Piston Assembly.
- CAUTION: Valve parts (21), (24) and (25) must be kept together or replaced as a kit (680A40).
- **Shift Piston Disassembly:**
- Clamp it into the large hole of clamp wrench 680A48/49, locating on a polished surface. Tighten the wrench's cap screws securely; place the clamp wrench in a vise so the shift piston is facing upward. Place Shift Piston Tool 700A63 over the threads and against the shoulder of the head piston (16) to protect the seals. Remove the Piston Cap (12) with a second clamp wrench (680A48/49) tightened around the cap (smaller hole); use caution as the spring will pop out upon disassembly.
- Remove the valve seat (24) with an 11/16" wrench. Remove the valve stem (21) and the valve spring (19).
- **End Cap Disassembly**
- Turn the Cap Screw (37) counterclockwise until it stops (use a 5/32" hex key); remove the spiral Retaining Ring (29) with a sharp or pointed instrument- the Cap Screw (37) can then be turned clockwise until the Shift Stop (25) can be removed.
- Remove the Shift Screw (28) with 3/16 hex key; hold screw (37) with a 5/32" hex wrench. Remove the Cap Screw and the Index Washer (36 & 37). Push the Shift Screw (28) out.
- Remove the Release Piston (26) from the Rear Cap (33)

After servicing the tool, reverse the above procedures to re-assemble; make sure to use the proper tools and tighten the Front-end Cap (3) to 150-180 ft.-lbs. (203 to 244 N-m) torque.

HANDLE SUB-ASSEMBLY**Disassembly:**

- Remove parts (84) through (87). Remove screws (70). Lift head assembly from the handle; empty and dispose of fluid according to environmental regulations.
- Unthread the locknut (82) with a 1/2" socket wrench and then remove the air piston (81) by using wrench 700B65; hold the top of the piston with tool 700A61 to prevent from turning. Push piston out when completely unthreaded
- Push the Power Piston (59) all the way up and remove packing plug (78) with the help of wrench 700B65.
- Tap the power cylinder (66) from the top; when loosened, it will fall through the bottom.
- Remove all the seals using a bent hook tool.

Assembly:

- The re-assembly sequence is the opposite of disassembly; to prevent damage to piston threads, the tightening torque for the locknut (82) must be between 50 and 59 in.-lb. (5.65 and 6.67 N-m).

G784 CROSS SECTION DRAWING

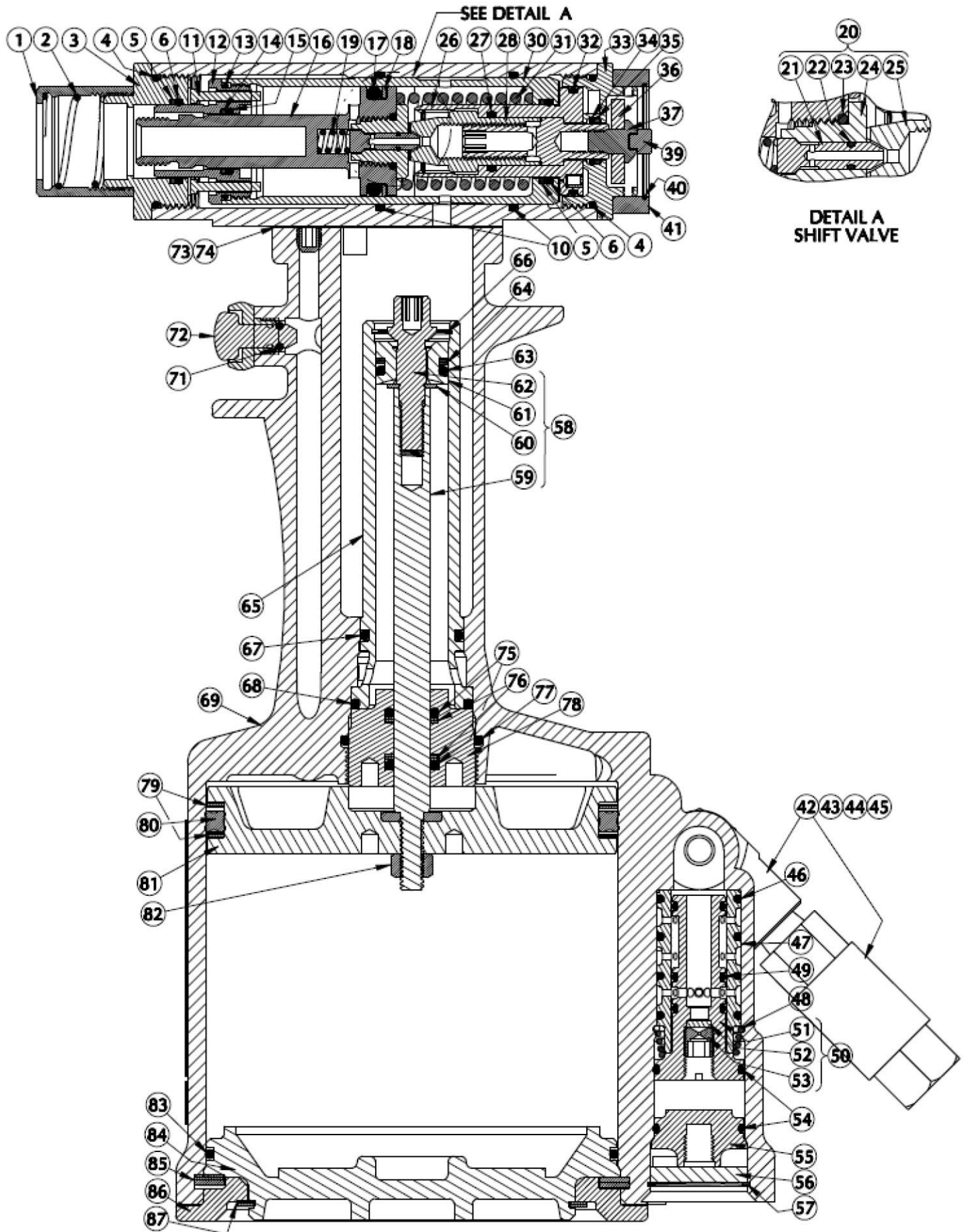

PART LIST FOR G784 (ITEM 784C1)

ITEM NO.	Part No.	DESCRIPTION	QTY.	
784C3 HEAD CYLINDER ASSEMBLY				
1	680A103	SLEEVE CAP	1	
2	680A105	SPRING	1	
3	680B98	FRONT CAP	1	
4	P691	O-RING (1.254, 1.114, .070)	2	
5	P652	BACK-UP RING (.874, .768, .053)	2	
6	P826	O-RING (.879, .739, .070)	2	
7	784C2	HEAD CYLINDER BODY	1	
8	P572	STAT-O-SEAL (.430, .180, .125)	2	
9	P573	BUTTON HD. CAP SCREW 10-32X1/4	2	
10	P904**	DISOGRIN O-RING (1.441, 1.301, .070)	2	
11	680A21	PISTON STOP	4	
12	680B99	PISTON CAP	1	
13	P266	O-RING (1.191, 1.051, .070)	1	
14	P651	BACK-UP RING (.686, .580, .053)	1	
15	P828**	DISOGRIN O-RING (.694, .551, .070)	1	
16	680B151	HEAD PISTON	1	
17	P483	O-RING (1.137, .859, .139)	1	
18	P657	BACK-UP RING (1.127, .891, .118)	1	
19	680A111	SHIFT VALVE SPRING	1	
20	680A40	SHIFT VALVE	1	
	21	680A20*	STEM, VALVE	1
	22	P706	O-RING (.192, .116, .038)	1
	23	P298	O-RING (.566, .426, .070)	1
	24	680A18*	VALVE SEAT	1
	25	680A19*	SHIFT STOP	1
26	680A308	RELEASE PISTON SUB-ASSEMBLY	1	
27	P830**	DISOGRIN O-RING (.629, .489, .070)	1	
28	680A95	SHIFT SCREW	1	
29	P768	RETAINING RING (INT. Ø.625)	1	
30	680C3	SHIFT PISTON	1	
31	680A10	PISTON SPRING	1	
32	P690	O-RING (1.129, .989, .070)	1	
33	680B93	REAR CAP	1	
34	P112	O-RING (.504, .364, .070)	1	
35	P650	RING BACK-UP (.496, .390, .053)	1	
36	680A92	INDEX WASHER	1	
37	P554	BUTTON HEAD CAP SCREW, 1/4-28X3/8	1	
38	P356	SOC. HEAD. CAP SCREW, 4-40X1/4	2	
39	680A113	ADJUSTER KNOB	1	
40	680A112-2	FRICTION SPRING	1	
41	680A112	ADJUSTER RING (INCLUDES 680A112-2)	1	

ITEM NO.	Part No.	DESCRIPTION	QTY.	
784C5 HANDLE ASSEMBLY				
42	530A35	SWIVEL BOLT	1	
43	P195	O-RING (.630, .424, .103)	2	
44	530A34	SWIVEL	1	
45	P1505	PRESET PRESSURE REGULATOR	1	
46	P268	O-RING (.816, .676, .070)	4	
47	740B14	VALVE SLEEVE	1	
48	740A18	SPRING	1	
49	P891**	DISOGRIN O-RING (.566, .426, .070)	3	
50	740A15	VALVE SPOOL SUB-ASSEMBLY	1	
	51	740B15-1*	VALVE SPOOL	1
	52	700A18*	FILTER	1
	53	700A69*	METERING SCREW	1
54	P848	O-RING (.941, .801, .070)	2	
55	740B16	VALVE PLUG	1	
56	740A17	MUFFLER	1	
57	P321	RETAINING RING (INT. Ø 1.000)	1	
58	740A8	POWER PISTON & ROD ASSEMBLY	1	
	59	740A10*	POWER PISTON ROD	1
	60	740A12*	PISTON STOP	1
	61	740A9*	POWER PISTON	1
	62	740A11*	CAP, PISTON ROD	1
63	P508	O-RING (.755, .549, .103)	1	
64	P908	BACK-UP RING (.738, .562, .088)	1	
65	740C7	POWER CYLINDER	1	
66	P885	RETAINING RING	1	
67	P892**	DISOGRIN O-RING (1.255, 1.049, .103)	1	
68	P833**	DISOGRIN O-RING (1.068, .862, .103)	1	
69	740R3	HANDLE	1	
70	P71	SOC. HEAD CAP SCREW, 10-32X1/2	4	
71	P223	O-RING (.285, .145, .070)	1	
72	703A33	TRIGGER ASSEMBLY (INCLUDES P223)	1	
73	700A22	GASKET	1	
74	P832**	DISOGRIN O-RING (.379, .239, .070)	1	
75	P838**	DISOGRIN O-RING (.568, .362, .103)	2	
76	P115	BACK-UP RING (.551, .375, .088)	2	
77	P889	O-RING (1.505, 1.299, .103)	1	
78	740B13	PACKING PLUG	1	
79	P909	BACK-UP RING (4.245, 3.875, .185)	2	
80	P887	QUAD RING	1	
81	740B6	AIR PISTON	1	
82	P737	CONELOK NUT, 1/4-20	1	
83	P890	O-RING (4.193, 3.987, .103)	1	
84	740C4	HANDLE BASE	1	
85	P886	RETAINING RING (INT. Ø 4.250)	1	
86	740B5	BASE COVER	1	
87	P884	RETAINING RING (EXT. Ø 3.375)	1	
87	435-092	CE CERTIFICATION LABEL	1	

*These parts cannot be purchased separately but must be ordered as a sub-assembly.

** No Substitutions.

EXPLODED VIEW OF G784

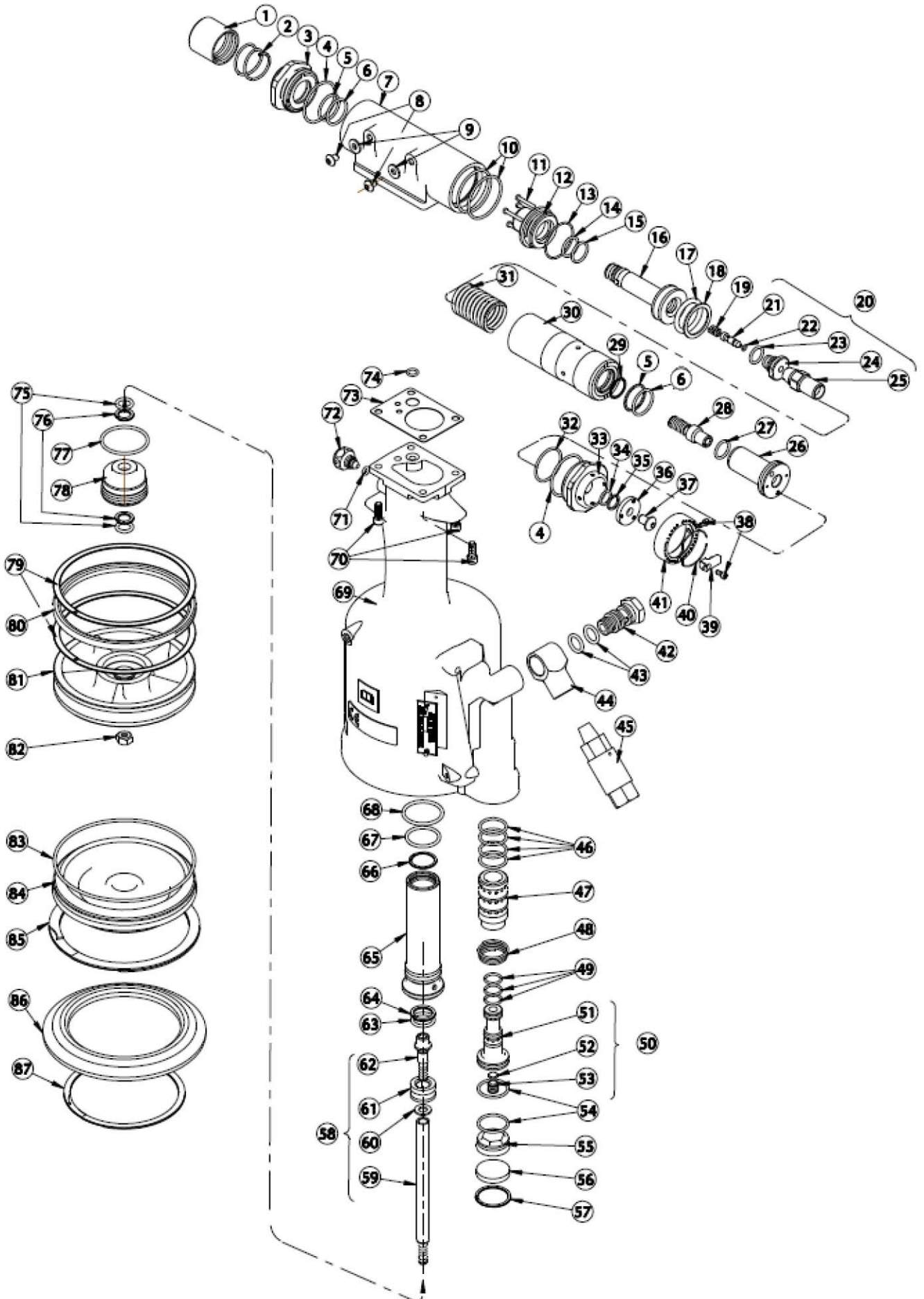

THE HYDRAULIC SYSTEM

RECOMMENDED HYDRAULIC FLUID

The riveter is supplied with Dexron® III ATF type "A".

Specific gravity:	0.863
Weight per gallon:	7.18 lbs.
Open flash point:	>200°C (392°F)













COMPATIBLE ALTERNATE FLUIDS

- **Automatic Transmission Fluids:** DEXRON IV, MERCON, Allison C4 or equivalent.
- **Hydraulic Fluids:** Hyspin® VG32, Aeroshell fluid 4

⚠ CAUTION ⚠

- **DO NOT MIX DIFFERENT TYPES OF HYDRAULIC OILS AND TRANSMISSION; HYDRAULIC AND TRANSMISSION FLUIDS ARE NOT COMPATIBLE DIFFERENT TYPES OF FLUIDS MAY NOT BE COMPATIBLE WITH EACH OTHER.**
- **PHYSICAL PROPERTIES AND MATERIAL SAFETY DATA SHEETS FOR DIFFERENT FLUIDS MAY DIFFER FROM THE ONE GIVEN BELOW, BUT THE SAFETY INFORMATION STILL APPLIES; CHECK WITH THE FLUID MANUFACTURER FOR ADDITIONAL MSDS AND SPECIFIC PROPERTIES.**

FLUID HANDLING SAFETY

 ENVIRONMENTAL		<ul style="list-style-type: none"> • Waste Disposal in accordance with the applicable regulations
		<ul style="list-style-type: none"> • Soak up spills with diatomaceous earth or other inert materials. • Keep from drains, sewers and water courses. • Filter and recycle used fluid; otherwise store and dispose of according to the applicable regulations.
 HANDLING	 Approved Personal Protective Equipment must be worn	<ul style="list-style-type: none"> • Eye protection is required. • Protective gloves, chemically resistant boots and apron are recommended.
 FIRST AID		<ul style="list-style-type: none"> • Flush eyes thoroughly with water. • If irritation develops, consult a physician.
		<ul style="list-style-type: none"> • To prevent inhalation, use in well-ventilated area. • Short term exposure should pose no adverse health effects. • If inhalation occurs, remove the affected person from the contaminated area and apply artificial respiration if needed.
		<ul style="list-style-type: none"> • DO NOT INDUCE VOMITING. • Seek medical attention immediately.
		<ul style="list-style-type: none"> • IN CASE OF SKIN CONTAMINATION: • Wash thoroughly with soap and water as soon as possible. • Brief skin contact requires no immediate attention. • If irritation develops, consult a physician.
 COMBUSTIBILITY		<ul style="list-style-type: none"> • It is slightly combustible when heated above flash point. • It will release flammable vapors which can burn in open or be explosive in confined spaces if exposed to source of ignition. • Do not store near open flames or other sources of ignition.
		<ul style="list-style-type: none"> • In case of fire, use only suitable extinguishing media: CO2, dry powder, foam or water fog. • CAUTION: DO NOT USE WATER JETS.

PRIMING THE TOOL

- To completely refill the tool (after the tool has been dismantled and re- assembled) take the following steps:
 1. With the Head Cylinder removed, fill the Handle Assembly with fluid to within about 1/8" from the top; re-assemble and tighten the Head Cylinder.
 2. Connect to an air source and remove Screws 8 from Head Cylinder (7).
 3. Connect a pressurized fluid source to the front hole; circulate fluid until it flows smoothly, without spurting or air bubbles through the rear hole.
 4. Re-attach the front Screw (8) and bleed per instructions below.

BLEEDING INSTRUCTIONS

- Remove back Screw (8) and connect the Air Bleeder (700A77) to the rear hole as shown in the picture on the left; trigger the tool several times until there are no air bubbles coming into the bleeder.
- Re-attach and tighten Screw and Stat-O-Seal (items 8 & 9).



TROUBLESHOOTING

PROBLEM	POSSIBLE REASONS / SOLUTIONS
Piston does not move after depressing Trigger	- No air supply is connected: Connect to a clean, filtered air source at 90 to 110 psi (6,2 to 7,6 bar).
	- Faulty trigger: Remove and replace trigger assembly.
	- Broken power piston: Service the Handle Subassembly.
Short stroke or low pull force	- Significant fluid loss: Bleed the system to purge the air out. If performance doesn't improve, or excessive leakage continues, see below.
Head Cylinder Fluid leakage	- Leaks around the seals or fittings indicate that they are not tightened to seal properly: Tighten until no more leaks are observed.
	- Leaks at the front or back of head cylinder indicate worn/ damaged seals
	- Service head cylinder per instructions provided herein
Air leakage at the spool valve	- Broken or dislodged valve spring.
	- Worn or damaged valve spool seals: Disassemble and service air valve per Air Sub-Assembly Overhaul Instructions.
Head piston is slow or seizes	- Piston or seal damage: Service head cylinder.
	- Oil bypassing due to power piston displacement off its seat: Service Handle Subassembly per instructions provided below.
	- Clogged air muffler or filter Clean thoroughly with solvent and back-blow with compressed air.
Shift Piston does not move forward	- Worn Seals or seized Shift Piston Assembly: disassemble and service the Head Cylinder
	- Shift Valve spring (19) is damaged or broken: Inspect valve seat, poppet and spring; clean and replace as necessary.



Declaration of Conformity

We, **Cherry Aerospace**

Located at **1224 East Warner Avenue, Santa Ana, CA 92705-0157, USA,**

In accordance with the provisions of
Machine Directive 2006/42/EC

Hereby declare under our sole responsibility that:

Equipment: **Pneumatic Hydraulic Hand Riveter**

Model Number: **G784**

Serial Number: _____

Date of Issue: _____

Is in conformity with the applicable requirements of the following standards:

EN ISO 12100:2010 Safety of Machinery; General Principles; Risk Assessment and Reduction

ISO/TR 14121-1&2:2012 Safety of Machinery, Risk Assessment

ISO11148-1:2011 Hand Held Non-Electric Power Tools- Safety Requirements

ISO 8662-11:1999 Hand-Held Portable Power Tools -- Measurement of Vibrations at the Handle

ISO 3744:2010 Acoustics – Determination of sound power levels of noise sources

ISO 4413:2010 Hydraulic Fluid Power - General Rules of Safety

ISO 4414:2010 Pneumatic Fluid Power - General Rules of Safety

Signed by: 

Cris Cobzaru,
Sr. Technical Services / Installation Tooling Engineer
Master of Science in Mechanical Engineering

