

H1900-456

CHERRY 1900® PULLING HEAD

Technical Data Sheet, Page 1 of 2



CHERRY®
AEROSPACE

DIMENSIONAL DATA

(all measurements in inches)

- Tool weight without riveter: .27 Lbs (0.122 Kg).

CHOICE OF RIVETER

- **G83** Cherry® Riveter
- **G84** Cherry® Riveter
- Or any riveter equipped with a 352 Style Mounting System

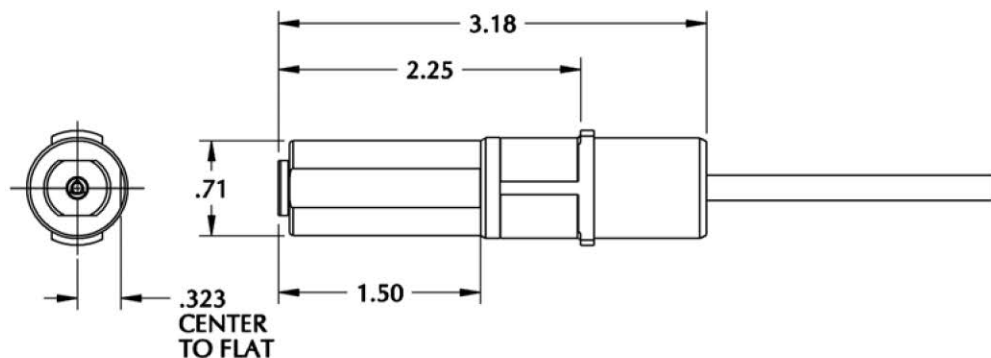

MOUNTING INSTRUCTIONS

- Attach riveter to air source for correct piston positioning;
- Thread collet assembly securely onto the riveter head piston, use guide tube (item 7) when installing -4 and -5 NAS1919/1921 product. Only remove guide tube (item 7) for -6 installations.
- Press the trigger and attach the sleeve assembly onto the bayonet mount.

USAGE

- The H1900-456 is designed to reliably install all sizes of the single action NAS1919/1921 product assembled with or without a drive washer. To install the product without a drive washer use the appropriate nose piece (item 1) as shown in table 1.
- Consult the fastener product standard page for hole preparation and other fastener related information.
- Note that installations of fasteners with grip dash numbers -06 and up may require double triggering depending on the riveter being used.

BEFORE USE, MAKE SURE THAT:

- The nose piece (item 1) is properly threaded onto the sleeve (item 2) and the pulling head is properly mounted on the recommended riveter.
- The proper air source is connected.

DURING OPERATION

- Inspect the active area of the nose piece regularly.
- Keep the tool clean, especially the nose piece and jaws; pay special attention when sealants are used.
- If stem slippage occurs, the jaws need to be either cleaned or replaced.

PREVENTATIVE MAINTENANCE

- Clean the nose piece, jaw set and collet every 1,000 installations, or when failure occurs; use a wire brush to clean debris trapped in the jaw set.
- Lubricate outside of the jaw set with Lubriplate® or similar light lubricant.

USATCO U.S. Air Tool Company, Inc.

Eastern Division60 Fleetwood Ct., Ronkonkoma, NY 11779-6907 tel: (631) 471-3300 fax: (631) 471-3308
Western Division1219 W. Mahalo Place, Rancho Dominguez, CA 90220-5446 tel: (310) 632-5400 fax: (310) 632-3900

Info@usatco.com

H1900-456

CHERRY 1900® PULLING HEAD

Technical Data Sheet, Page 2 of 2



CHERRY®
AEROSPACE

PARTS LIST

8	190-007	DRAWBOLT ADAPTOR	1
7	190-008	GUIDE TUBE	1
6	P1481	COMPRESSION SPRING	1
5	652-116	JAW FOLLOWER	1
4	743C55	JAW SET	1
3	747-041	COLLET	1
2	190-002	SLEEVE ASSEMBLY	1
1	190-010	NOSE PIECE	1
ITEM No.	PART NUMBER	DESCRIPTION	QTY. PER

- When re-assembling use Loctite® 242 (removable) on the Nose Piece and Collet threads.

Table 1. Nose piece selection for fasteners without a drive washer

FASTENER DIAMETER	NOSE PIECE
-4	190-013
-5	190-014
-6	190-015

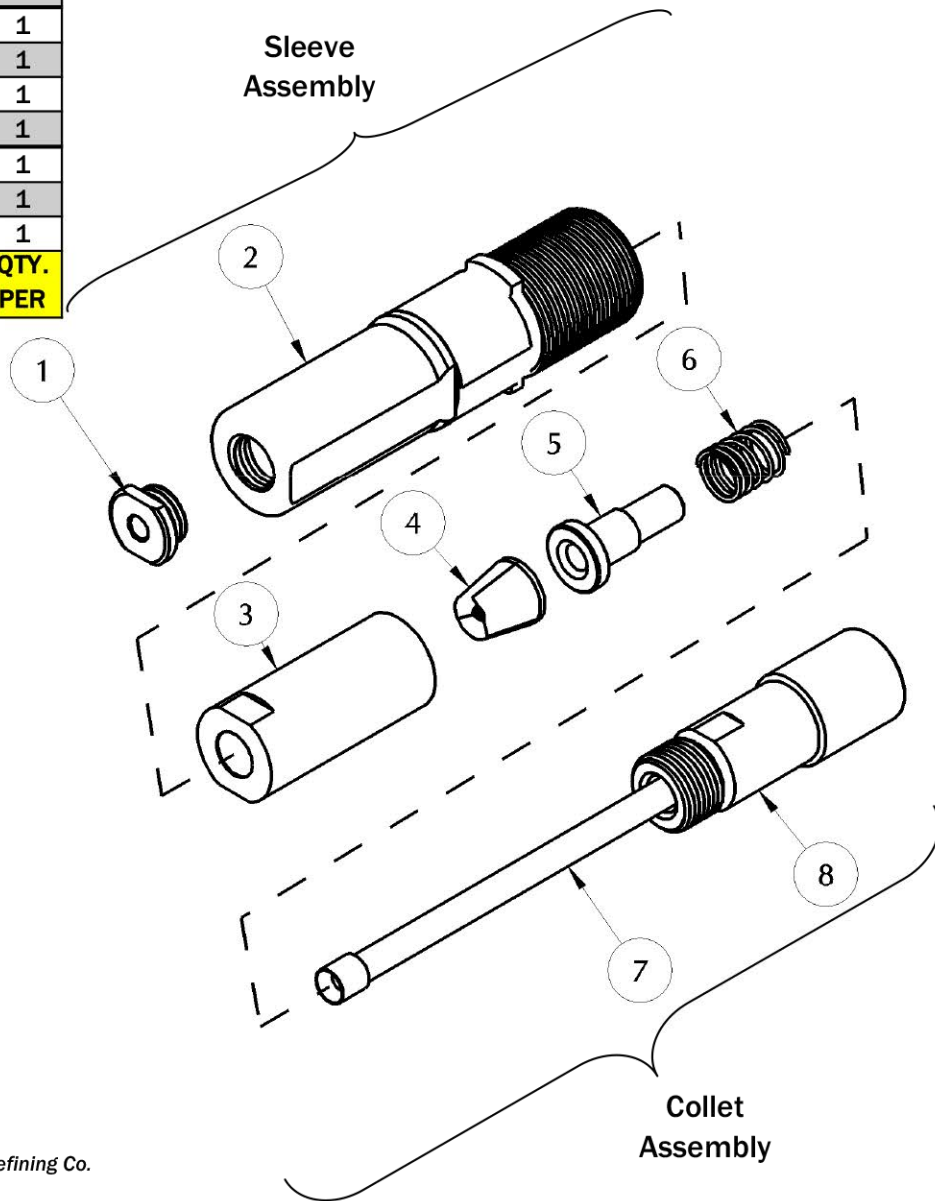

GENERAL / TECHNICAL QUESTIONS

1224 E. Warner Avenue
Santa Ana, CA 92705 USA
1-714-850-6022 (Phone)
1-714-850-6093 (Fax)

LOCTITE® is a registered trademark of Henkel Corporation.
LUBRIPLATE® is a registered trademark of Fiske Brothers Refining Co.

WARRANTY

Seller warrants the goods conform to applicable specifications and drawings and will be manufactured and inspected according to generally accepted practices of companies manufacturing industrial or aerospace fasteners. In the event of any breach of the foregoing warranty, Buyer's sole remedy shall be to return defective goods (after receiving authorization from Seller) for replacement or refund of the purchase price, at the Seller's option. Seller agrees to any freight costs in connection with the return of any defective goods, but any costs relating to removal of the defective or nonconforming goods or installation of replacement goods shall be Buyer's responsibility. SELLER'S WARRANTY DOES NOT APPLY WHEN ANY PHYSICAL OR CHEMICAL CHANGE IN THE FORM OF THE PRODUCT IS MADE BY BUYER. THE FOREGOING EXPRESS WARRANTY AND REMEDY ARE EXCLUSIVE AND ARE IN LIEU OF ALL OTHER WARRANTIES AND REMEDIES; ANY IMPLIED WARRANTY AS TO QUALITY, FITNESS FOR PURPOSE, OR MERCHANTABILITY IS HEREBY SPECIFICALLY DISCLAIMED AND EXCLUDED BY SELLER. This warranty is void if seller is not notified in writing of any rejection of the goods within ninety (90) days after receipt of the goods by buyer.

Seller shall not be liable under any circumstances for incidental, special or consequential damages arising in whole or in part from any breach by Seller, AND SUCH INCIDENTAL, SPECIAL, OR CONSEQUENTIAL DAMAGES ARE HEREBY EXPRESSLY EXCLUDED.

Our policy is one of continuous development. Specifications shown in this document may be subject to changes introduced after publication.

NOTE: The properties, strength, dimensions, installed characteristics and all other information in these materials are for guidance only to aid in the correct selection of the products described herein and is not intended or implied as part of the above warranty. All applications should be evaluated for functional stability and available samples of the described parts can be requested for installed tests, suitability and evaluations.

For more information please contact our Technical Services Department at tel. 714-850-6022

USATCO U.S. Air Tool Company, Inc.

Info@usatco.com

Eastern Division60 Fleetwood Ct., Ronkonkoma, NY 11779-6907 tel: (631) 471-3300 fax: (631) 471-3308
Western Division1219 W. Mahalo Place, Rancho Dominguez, CA 90220-5446 tel: (310) 632-5400 fax: (310) 632-3900