



Original Instructions

# G84

Lockbolt Power Tool

 Instruction Manual   
Pass on to user to read and keep for reference

# MANUAL



**CHERRY**®  
AEROSPACE



# THE G84 TOOL

## TABLE OF CONTENTS

Description ..... 3

Specifications for G84 ..... 3

Safety Warnings ..... 3

Putting the tool in service ..... 4

How to Use the G84 ..... 4

    Lockbolt Pulling Pulling-Heads ..... 5

    Maxibolt Pulling Pulling-Heads ..... 5

    Adaptors and Cherrymax Pulling-Heads..... 5

Maintenance and Repair / Fluid Safety Data ..... 6

Fill and Bleed Instructions ..... 6

Tool Overhaul ..... 7

    Air Valve ..... 7

    Head Sub-Assembly ..... 7

    Handle Sub-Assembly ..... 8

Troubleshooting ..... 8

Cross Section Drawing ..... 9

Parts List..... 10

Exploded View of G84 ..... 11

Declaration of Conformity ..... Back Cover

### WARRANTY

Seller warrants the goods conform to applicable specifications and drawings and will be manufactured and inspected according to generally accepted practices of companies manufacturing industrial or aerospace fasteners. In the event of any breach of the foregoing warranty, Buyer's sole remedy shall be to return defective goods (after receiving authorization from Seller) for replacement or refund of the purchase price, at the Seller's option. Seller agrees to any freight costs in connection with the return of any defective goods, but any costs relating to removal of the defective or nonconforming goods or installation of replacement goods shall be Buyer's responsibility. SELLER'S WARRANTY DOES NOT APPLY WHEN ANY PHYSICAL OR CHEMICAL CHANGE IN THE FORM OF THE PRODUCT IS MADE BY BUYER.

**THE FOREGOING EXPRESS WARRANTY AND REMEDY ARE EXCLUSIVE AND ARE IN LIEU OF ALL OTHER WARRANTIES AND REMEDIES; ANY IMPLIED WARRANTY AS TO QUALITY, FITNESS FOR PURPOSE, OR MERCHANTABILITY IS HEREBY SPECIFICALLY DISCLAIMED AND EXCLUDED BY SELLER. THIS WARRANTY IS VOID IF SELLER IS NOT NOTIFIED IN WRITING OF ANY REJECTION OF THE GOODS WITHIN ONE (1) YEAR AFTER INITIAL USE BY BUYER OF ANY POWER RIVETER OR NINETY (90) DAYS AFTER INITIAL USE OF ANY OTHER PRODUCT.**

Seller shall not be liable under any circumstances for incidental, special or consequential damages arising in whole or in part from any breach by Seller, AND SUCH INCIDENTAL, SPECIAL, OR CONSEQUENTIAL DAMAGES ARE HEREBY EXPRESSLY EXCLUDED.

**For more information please contact our Technical Services Department at Tel. 714-850-6022**

LOCTITE® is a registered trademark of Henkel Corporation  
DEXRON® is a registered trademark of GM corporation.  
PARKER® is a trademark of Parker Hannifin Corporation  
LUBRRIPLATE® is a trademark of Fiske Brothers Refining Co.

**USATCO U.S. Air Tool Company, Inc.**

**Info@usatco.com**

**Eastern Division** ..... 60 Fleetwood Ct., Ronkonkoma, NY 11779-6907 tel: (631) 471-3300 fax: (631) 471-3308

**Western Division** ..... 1219 W. Mahalo Place, Rancho Dominguez, CA 90220-5446 tel: (310) 632-5400 fax: (310) 632-3900

## DESCRIPTION

The Cherry® G84 pneumatic-hydraulic Lockbolt™ installation tool is a heavy duty production tool designed for high speed, reliable installation of the most popular sizes of aircraft Lockbolts™.

This powerful tool has been designed with many ergonomic features: light weight (7.70 lb.), (3.5 kg), low recoil and noise, a comfortable fit in the operator's hand. The piston returns with a force of 1200 Lbs., force necessary when used for Lockbolt™ swaging.

This tool can also be used to install blind bolts and rivets.

## SPECIFICATIONS FOR G84A

Cherry® Aerospace (CHERRY®) policy is one of continuous development. Specifications shown in this document may be subject to change which may be introduced after publication. For the latest information always consult CHERRY®.

AIR PRESSURE RANGE	90 psi (6.2 bar) / 100 psi (6.89 bar) (use P1505 regulator pre-set at 100 psi)
STROKE	9/16 inch (14.3 mm)
PULLING FORCE	5,750 lbs. (25.6 kN) @ 100 psi, 1200 lbs. (5.34 kN) on return stroke
WEIGHT	7.70 lbs. (3.5 kg)
NOISE LEVEL	less than 80 dB (A)
VIBRATION	less than 2.5 m/s <sup>2</sup>
AIR CONSUMPTION	0.29 SCF/cycle (8.21 L/cycle)

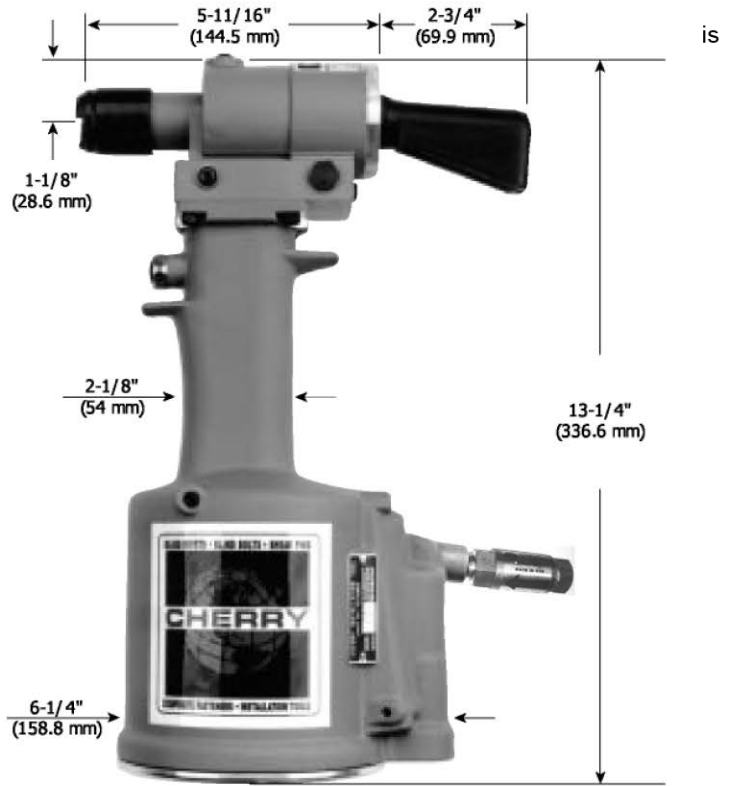

## SAFETY WARNINGS

- Do not use beyond the design intent; do not use substitute components for repair.
- Use the tool with a pressure regulator; if one is not available, use the Cherry P-1505.
- Operating this tool with a damaged or missing stem deflector, or using the deflector as a handle, may result in severe personal injury. Rotate the pin deflector facing away from the operator
- Wear proper PPE when operating, repairing, or overhauling this tool ( )
- Any modification will void warranty and shall be at the customer's entire responsibility.
- Maintain the tool in a safe working condition at all times and examined at regular intervals for damage.
- Before disassembling the tool for repair, refer to the maintenance instructions. All repairs shall be undertaken only by personnel trained in Cherry installation tools.
- Disconnect the air line from the tool inlet before servicing, adjusting, fitting or removing any accessory.
- Ensure that the vent holes do not become blocked or clogged and the hoses are in good condition.
- Wash thoroughly after handling the fluid; excessive contact could cause rashes.
- Operating air pressure not to exceed 110 psi (7.6 bar); use of a pre-set regulator (P1505) is recommended
- Do not operate the tool without the pulling head in place.
- All retaining rings, screwed end caps, air fittings, trigger valves and pulling heads should be attached securely and examined at the end of each working shift.
- Do not pull rivet in the air or directed at any person.
- Do not pound on the rear of the tool head to force rivets into holes as this will damage the tool.
- Safety warnings must be explained all operators as part of training.

USATCO U.S. Air Tool Company, Inc.

[Info@usatco.com](mailto:Info@usatco.com)

Eastern Division .....60 Fleetwood Ct., Ronkonkoma, NY 11779-6907 tel: (631) 471-3300 fax: (631) 471-3308  
 Western Division .....1219 W. Mahalo Place, Rancho Dominguez, CA 90220-5446 tel: (310) 632-5400 fax: (310) 632-3900



## PUTTING THE TOOL IN SERVICE

The tool must be used with an air pressure regulator. Even if your shop air pressure is below the maximum recommended range, pressure spikes in your airlines could cause serious damage to the tool or cause safety concerns.

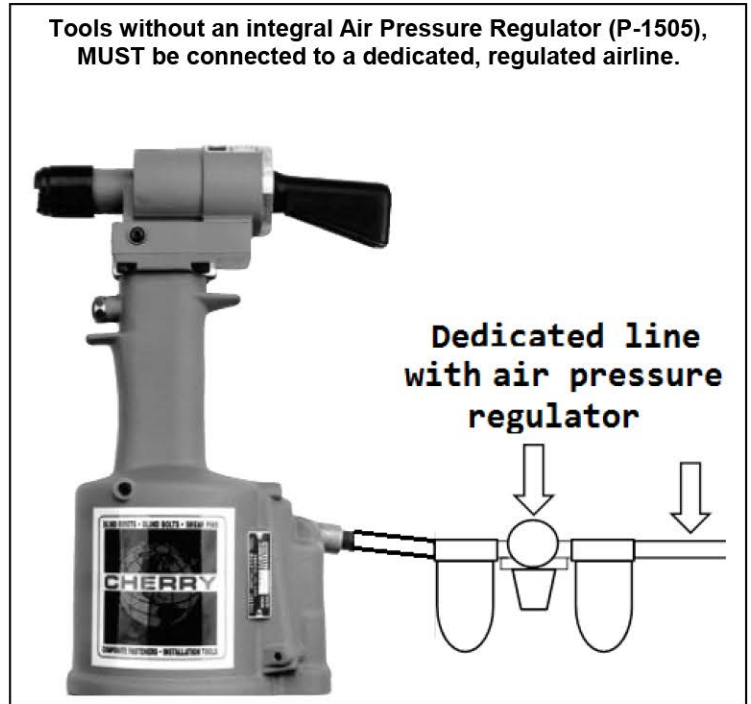
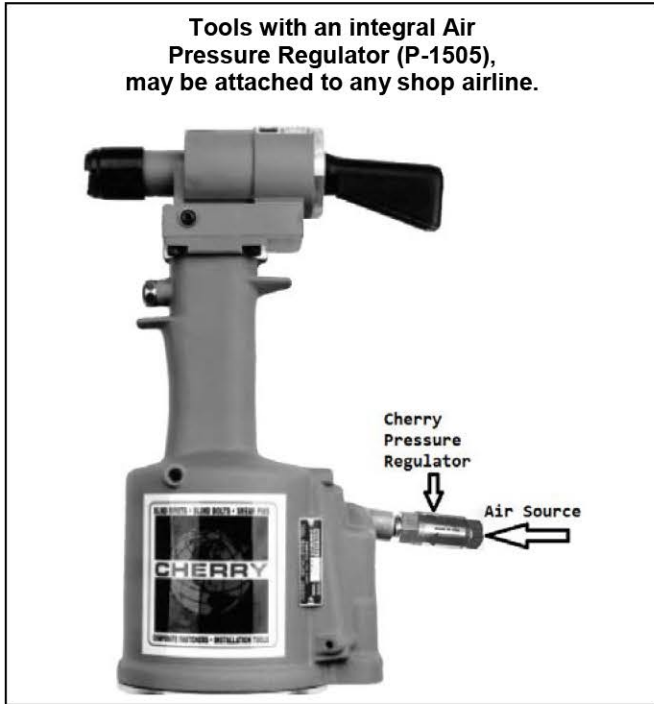

## HOW TO USE THE G84



### LOCKBOLT INSTALLATION

After selecting the proper pulling head and attaching it securely to the G84, connect the air line to the tool.

**Lockbolts:** Place the lockbolt pin into the workpiece and place the collar over the pintail.

While holding the back end of the lockbolt in place, push the pulling head onto the serrated area of the stem.

- **Caution:** When using a non-self-releasing pulling head once the tool is placed onto the serrated end, it cannot be removed unless going through the installation cycle which breaks the serrated end of the bolt. The broken part (pintail) will eject through the rear of the riveter when using a straight pulling head and through the rear of the active area of the tool for when using offset pulling heads.

If the tool does not release the swaged collar after installation, it can be adjusted by adding shims behind the pulling head collet. If the tool still does not release, see troubleshooting instructions on page:  
See pulling head installation instructions.

### BLIND BOLTS AND RIVETS

- Insert the blind fastener into the prepared hole and place the tool onto the serrated stem.
- Pull the trigger to activate the tool. Upon release of the trigger, the stem will eject to the rear of the riveter when using straight pulling heads, and from the rear of the active area of the tool when using offset pulling head. Right angle pulling heads eject the stems through the front..

### PULLING HEADS

Pulling heads are not furnished and must be ordered separately. All Huck nose assemblies suitable for the 352 and 230 style tools will fit directly on this tool.

USATCO U.S. Air Tool Company, Inc.

**Info@usatco.com**

Eastern Division .....60 Fleetwood Ct., Ronkonkoma, NY 11779-6907 tel: (631) 471-3300 fax: (631) 471-3308  
Western Division .....1219 W. Mahalo Place, Rancho Dominguez, CA 90220-5446 tel: (310) 632-5400 fax: (310) 632-3900

## LOCKBOLT PULLING HEADS

### H513 SERIES STRAIGHT PULLING HEADS

The H513 series pulling heads are for 1/8" through 1/4" diameter lockbolts (see table below).

### H562/H563 OFFSET PULLING HEADS

The H562 and H563 series offset pulling heads can be used in limited access areas.

#### NOTES:

- No letter after P/N indicates basic head; "S" code indicates swivel nose; "SR" code indicates self-releasing swivel nose; "SRC" code indicates chisel shape, self-releasing, swivel nose; "SP" code indicates it intended for short pintail lockbolts.

- Part numbers with an asterisk fit directly on the Cherry® G84 tool; the rest require adapter 744-100to fit onto the G84 tool.

TYPE	DIA CODE	BASIC MODEL	SWIVEL NOSE TYPE	SWIVEL NOSE SELF-RELEASING TYPE	CHISEL SHAPE SWIVEL NOSE SELF-RELEASING TYPE.
STRAIGHT	-4	H513-04-20* H513-04-35* H513-04-60*	-	-	-
	-5	H513-05-35* H513-05-60*	H513S-05-20* H513S-05-35	H513SR-05-20* H513SR-05-35	H513SRC-05-20* H513SRC-05-35*
	-6	H513-06-20* H513-06-60*	H513S-06-20* H513S-06-24 H513S-06-35* H513S-06-48	H513SR-06-20* H513SR-06-24 H513SR-06-35* H513SR-06-48	H513SRC-06-20* H513SRC-06-35*
	-8	H513-08-35*	H513S-08-24 H513S-08-35* H513S-08-48	H513SR-08-24 H513SR-08-48	H513SRC-08-48
OFFSET	-4	H563-4B* H563SP-4B*	-	-	-
	-5	H563-5B* H563SP-5B*	-	-	-
	-6	H563-6B* H563SP-6B*	-	-	-
	-8	H562-8B	-	-	-

## MAXIBOLT PULLING HEADS

	PART NO.	MAXIBOLT DIA.	DESCRIPTION	ADAPTER
STRAIGHT PULLING HEADS	H83B-5MB/5MBU	-5	FOR SINGLE ACTION MAXIBOLT. USE "MBU" FOR "U" TYPE FASTENERS	N/A
	H83B-6MB/6MBU	-6		
	H84A-8MB/8MBU	-8		
	H84C-8MB	-8	EXTENDED REACH (6" LONGER)	
	H84CE6-8MB	-8	PREVENTS HEAD LIFT ON 130 HEAD FASTENERS	
	H84HL-5 OR 6 OR 8	-5 OR -6 OR -8	FOR MAXIBOLT PLUS FASTENERS	
	H84B-568	-5, -6, -8 MB Plus		
OFFSET	H856-6MB	-6		744-200
RIGHT ANGLE	H828-5MB	-5	FOR SINGLE ACTION MAXIBOLT.	744-200
	H828-6MB	-6		744-200
	H828-8MB	-8		744-200
	H828-56MBP	-8	FOR MAXIBOLT PLUS FASTENERS	744-200

## CHERRYMAX® PULLING HEADS AND ADAPTERS

PULLING HEAD	PART NO.	CHERRYMAX® DIAMETER	ADAPTER
STRAIGHT	H701B-456	-4, -5, -6	744-300
	H84A-8	-8	—
OFFSET	H781-456	-4, -5, -6	744-300
	H782	-4, -5, -6	744-300
	H827-8	-8	744-200
RIGHT ANGLE	H753A-456	-4, -5, -6	744-300
	H828-8	-8	744-200

STEP 1



STEP 2



STEP 3



### ADAPTOR MOUNTING INSTRUCTIONS

**STEP 1** Remove Bayonet mount with square shank screwdriver. Use even force to turn the bayonet mount free from the thread locking compound.

Do not hammer on the screw driver or bayonet mount. We recommend placing the tool carefully in a vise equipped with soft jaws. Store it for future use.

**STEP 2** Attach Drawbolt Adapter to head piston and tighten securely.

**STEP 3** Attach the Sleeve Adapter and tighten securely

## MAINTENANCE AND REPAIR

This riveter has been manufactured to give maximum service with minimum care. For optimum function:



1. The hydraulic system to be full of oil and free from air at all times.
2. Use clean and dry air to prevent premature wear and clogging of the air components.
3. Inspect the riveter for fluid leaks routinely

Use automatic transmission fluid (ATF ) type "A" (no substitutes). Cherry® Aerospace recommends using, Dexron® III ATF.

### FIRST AID

**Skin:** Wash thoroughly with soap and water as soon as possible. Casual contact requires no immediate attention. If irritation develops, consult a physician.

**Ingestion:** Seek medical attention immediately. **DO NOT INDUCE VOMITING.**

**Eyes:** Flush with copious amounts of water. If irritation develops, consult a physician.

**Inhalation:** No significant adverse health effects are expected to occur on short term exposure.

Remove from contaminated area. Apply artificial respiration if needed. If unconscious, consult physician.

### FIRE

Suitable extinguishing media: CO<sub>2</sub>, dry powder, foam or water fog. **DO NOT** use water jets.

### ENVIRONMENT

**Waste Disposal:** In accordance with local, state and federal regulations.

**Spillage:** Prevent entry into drains, sewers and water courses. Soak up with diatomaceous earth or other inert material.

Store the spent fluid in appropriate containers for disposal.

### HANDLING

Eye protection required. Protective gloves recommended. Chemically resistant boots and apron recommended. Use in well-ventilated area.

### COMBUSTIBILITY

It is slightly combustible when heated above flash point. It will release flammable vapors which can burn in open or be explosive in confined spaces if exposed to source of ignition.

### STORAGE

Avoid storage near open flame or other sources of ignition.

## PROPERTIES

<i>Specific gravity</i>	0.863
<i>Weight per gallon</i>	7.18 lbs.
<i>Open flash point</i>	>200°C (392°F)

## FILL AND BLEED INSTRUCTIONS



- To replace a small amount of oil in the tool, remove cap screw (21) from side of head cylinder and attach the 700A77 Air Bleeder (see picture). Connect the tool to the air line and cycle several times.
- To completely refill the tool (after the tool has been dismantled and re- assembled) take the following steps:



1. With the tool upright, connected to an air source, hold trigger down and disconnect the air. The Head Piston (10) should have moved back; if it hasn't push it back manually, using a press
2. Remove the screw (21) from the side of the head cylinder (13). Connect a pressurized fluid source filled with automatic transmission fluid Type "A".
3. Remove the screw (21) from the rear of the head cylinder (13). Force the fluid into the tool until it flows out the rear hole. Position the tool so the rear hole is the highest point. Keep pumping fluid until all air bubbles are out. Place the Screw (21) and the Seal (22) into the rear hole and tighten.
4. Remove the screw (21) from the top of the head cylinder (13). Force the fluid into the tool until it flows out the top hole. Position the tool in such a way that the top hole is the high point. Keep pumping the oil until all air bubbles are out.
5. Disconnect the pressure oil can from the side hole of the head cylinder (13). Replace screw (21) and Stat-O-Seal (22) and tighten.
6. Holding a cloth over the top hole, attach tool to an air source. Excess fluid and will be discharged into the cloth. Place the Screw (21) with the Seal (22) onto the top hole and tighten.

**NOTE:** For the purpose of bleeding, it is not necessary to remove the pressure relief valve (77). Do not remove any of the hex set screws from the head or the handle.



## TOOL OVERHAUL

Tool overhaul is needed in case of tool malfunction, massive fluid loss or as part of your routine maintenance program.

TOOLS NEEDED: **G740KT** – tool kit, **Needle Nose Pliers**,  
**G84KS** – service kit:

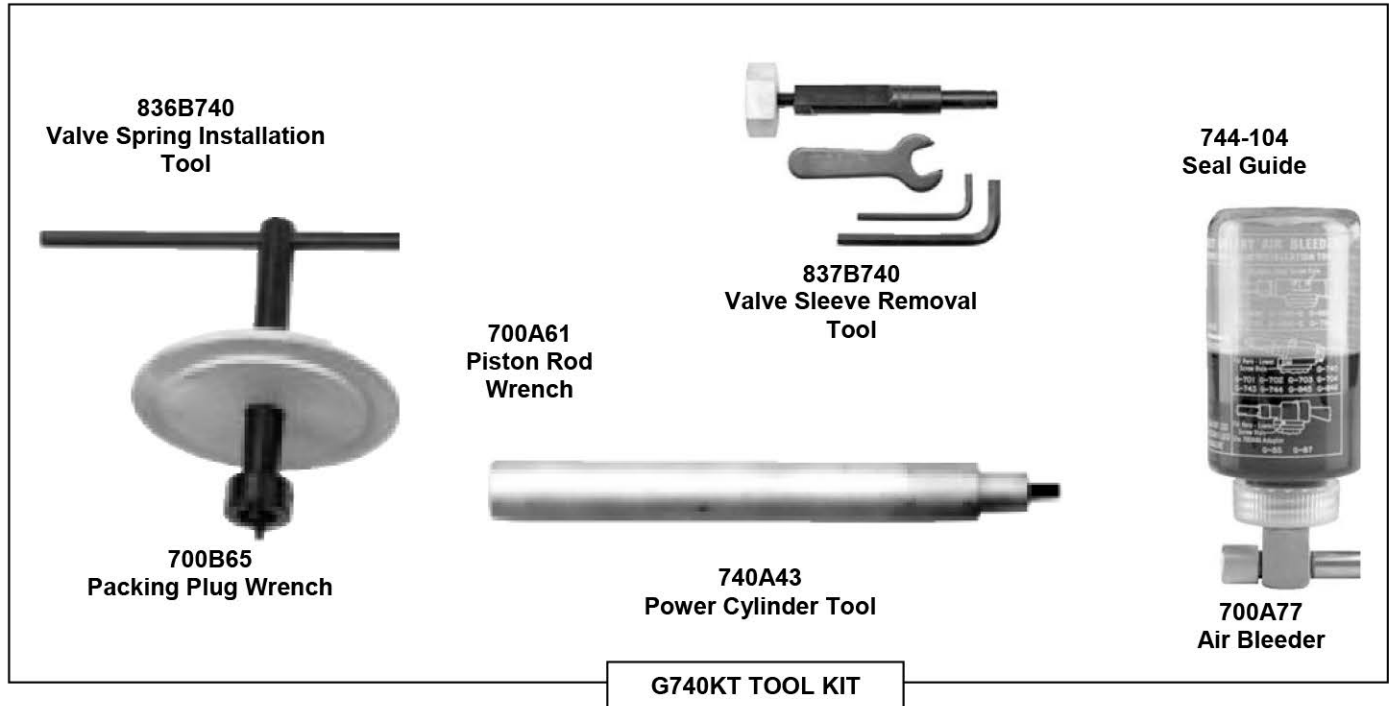

## OVERHAUL PROCEDURE

### Caution:

- Maintenance and repair to be conducted only by trained personnel.
- Prior to attempting any repair or maintenance work, make sure the air is disconnected.
- Follow these instructions. Use special care handling sealing surfaces to avoid damage.
- Replace all seals; before re-assembly, apply an O-ring lubricant (Parker® silicone lube or equivalent) on all O-rings
- Apply a small amount of Loctite® 242 on the threaded components; curing time about 30 to 60 minutes.
- After tool overhaul, fill and bleed per instructions on page 6.

## AIR VALVE SUB-ASSEMBLY

### Disassembly Instructions:

- Remove retaining ring (55) and muffler (54).
- Pull the valve plug (53) and spool subassembly (80) out with the help of tool P1178;
- If necessary, pull the valve sleeve (46) with I tool 837B740 after dislodging the spring (47) with a needle-nose pliers and pulling it out.

### Assembly Instructions:

- Reverse the above procedures. Use Install tool 836B740 to push spring (47) into its groove.

## HEAD SUB-ASSEMBLY

### Disassembly:

- Remove end cap (4). Thread tool 744-103 onto head piston (10) and push it out of the head cylinder (13).
- O-rings and back-up ring can be removed using a bent hook. Replace all seals.
- Remove the pressure relief valve sub-assembly (78); unscrew the ball seat (24) carefully from the spring seat (29) using soft jaws. When all components have been removed, clean and dry thoroughly

### Re-assembly:

- Reverse the above directions; before re-attaching, fill the handle with fluid to the top.

## HANDLE SUB-ASSEMBLY

### Disassembly:

- Remove parts (65) through (69). Remove screws (76). Lift head assembly from the handle (33); empty and dispose of fluid according to environmental regulations.
- Unthread the locknut (64) with a 1/2" socket wrench and then remove the air piston (63) by using wrench 700B65; hold the top of the piston with tool 700A61 to prevent from turning. Push piston out when completely unthreaded
- Push the power piston (79) all the way up and remove packing plug (59) with the help of wrench 700B65.
- Tap the power cylinder (37) from the top; when loosened, it will fall through the bottom.
- Remove all the seals using a bent hook tool.

### Assembly:

- The re-assembly sequence is the opposite of disassembly; to prevent damage to piston threads, the tightening torque for the locknut (64) must be between 50 and 59 in.-lb. (5.65 and 6.67 N-m).

## TROUBLESHOOTING GUIDE

PROBLEM	POSSIBLE REASONS / SOLUTIONS
Piston does not move after depressing Trigger	- <b>No air supply is connected:</b> Connect to a clean, filtered air source at 90 to 110 psi (6,2 to 7,6 bar).
	- <b>Faulty trigger:</b> Remove and replace trigger assembly.
	- <b>Broken power piston:</b> Service the Handle Subassembly.
Short stroke or low pull force	- <b>Significant fluid loss:</b> Bleed the system to purge the air out. If performance doesn't improve, or excessive leakage continues, see below.
Head Cylinder Fluid leakage	- <b>Leaks around the seals or fittings indicate that they are not tightened to seal properly:</b> Tighten until no more leaks are observed.
	- <b>Leaks at the front or back of head cylinder indicate worn/ damaged seals</b>
	Service head cylinder per instructions provided herein
Air leakage at the spool valve	- <b>Broken or dislodged valve spring.</b>
	- <b>Worn or damaged valve spool seals:</b> Disassemble and service air valve per Air Sub-Assembly Overhaul Instructions.
Head piston is slow or seizes	- <b>Piston or seal damage:</b> Service head cylinder.
	- <b>Oil bypassing due to power piston displacement off its seat:</b> Service Handle Subassembly per instructions provided below.
	- <b>Clogged air muffler or filter</b> Clean thoroughly with solvent and back-blow with compressed air.
Head Piston (64) does not return fully forward even after system bleeding	- <b>Pressure relief valve (78) malfunction:</b> Remove, inspect and clean components thoroughly. Replace seals and damaged components.
	- <b>Return Cylinder Spring (34) is damaged or broken:</b> Remove head assembly and replace the damaged spring. Re-assemble, fill and bleed per page 6.



# CROSS SECTION OF G84

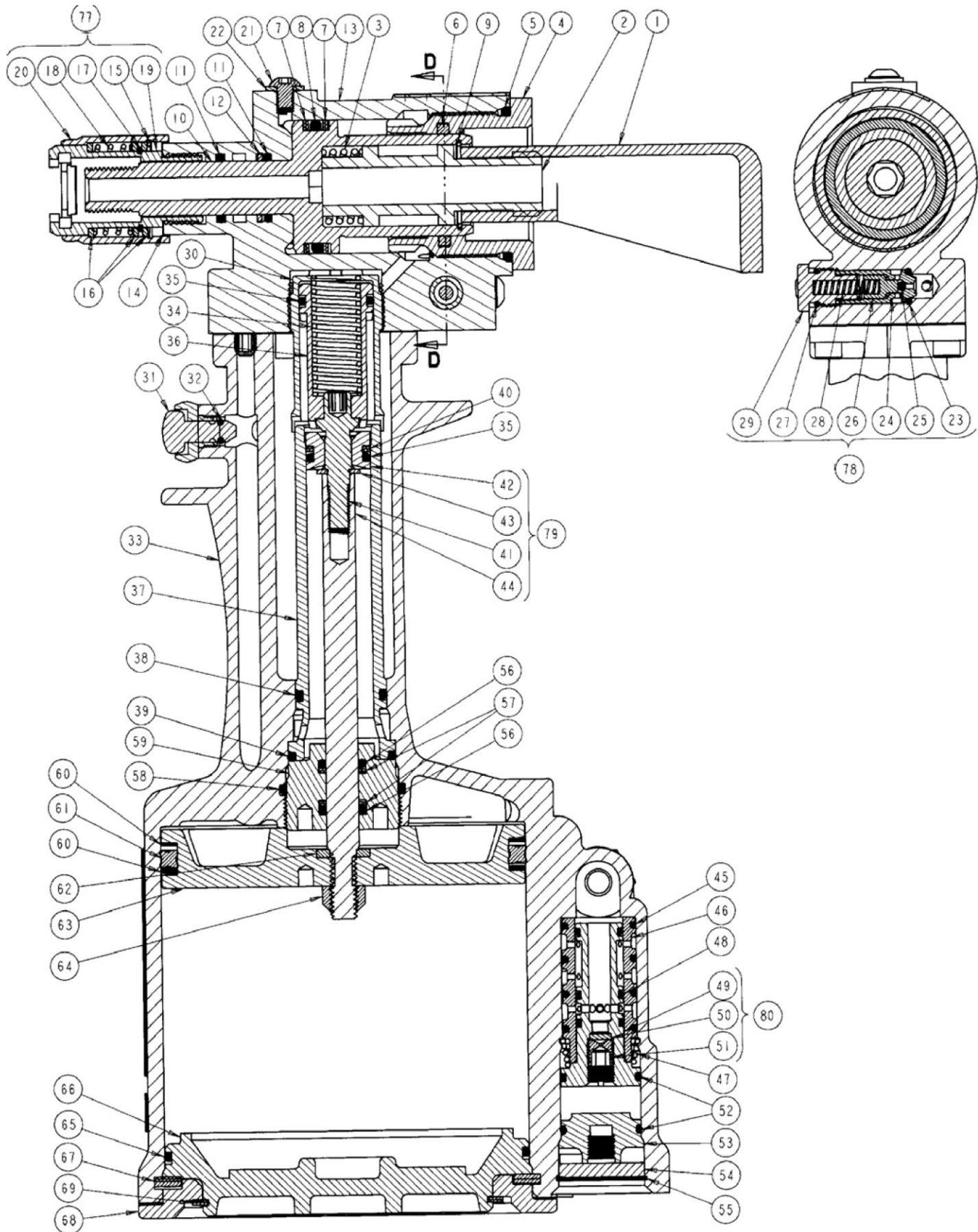

## PART LIST

### Model No.: G84 (P/N 744-090)

ITEM NO.	PART NO.	DESCRIPTION	QTY
<b>744-092 SUB-ASSEMBLY- HEAD</b>			
1	530A16	DEFLECTOR. PIN	1
2	560A17	FITTING, DEFLECTOR	1
3	530A20-1	SPRING	1
4	744-083	CAP, END	1
5	P-1252	O-RING	1
6	P-1389	RING. QUAD	1
7	P-1390	RING. BACK-UP	2
8	P-196	O-RING	1
9	P-300	RING. RETAINING	1
10	744-093	PISTON, HEAD	1
11	P-568	O-RING	2
12	P-242	RING. BACK-UP	1
13	744-096	CYLINDER. HEAD	1
14	700-258	SHIM. STEEL	A/R
<b>77 700-211 SUB ASSEMBLY, ADAPTER</b>			
	15	P-699 RING. RETAINING	1
	16	700-257 SPACER. ADAPTER	3
	17	P-957 RING. RETAINING	1
	18	P-1372 SPRING	1
	19	700-255 EXTENSION. HEAD	1
	20	700-256 SLEEVE, LOCKING	1
21	P-573	SCREW. BUTTON HD CAP, 10.32 X 1/4	3
22	P-572	STAT-O-SEAL	3
<b>78 700-214 SUB-ASSEMBLY. RELIEF VALVE</b>			
	23	P-111 O-RING	1
	24	700-215 SEAT. BALL	1
	25	P-688 BALL (3/32)	1
	26	700-217 PISTON. VALVE	1
	27	P-383 O-RING	1
	28	P-1366 SPRING	1
	29	700-218 SEAT SPRING	1
30	744-085	CYLINDER. RETURN	1
<b>744-091 SUB-ASSEMBLY. HANDLE</b>			
<b>31 703A33 SUB-ASSEMBLY. TRIGGER (includes P-223)</b>			
	32	P-223 O-RING	1
33	740R3	HANDLE	1
34	P-1391	SPRING	1
35	P-508	O-RING	2
36	744-084	PISTON, RETURN	1

ITEM NO.	PART NO.	DESCRIPTION	QTY
37	744-089	CYLINDER. POWER	1
38	P-833**	O-RING. DISOGRIN	1
39	P-892**	O-RING, DISOGRIN	1
40	P-908	RING. BACK-UP	1
<b>79 744-088 SUB-ASSEMBLY, POWER PISTON AND ROD</b>			
	41	744-087 CAP. PISTON ROD	1
	42	740A9 PISTON. POWER	1
	43	740A12 STOP. PISTON	1
	44	744-086 ROD. POWER PISTON	1
45	P-268	O-RING	4
46	740B14	SLEEVE. VALVE	1
47	740A18	SPRING	1
48	P-891**	O-RING, DISOGRIN	3
<b>80 740A15 SUB-ASSEMBLY. VALVE SPOOL</b>			
	49	740B15-1* SPOOL. VALVE	1
	50	700A18* FILTER	1
	51	700A69* SCREW. METERING	1
52	P-848	O-RING	2
53	740B16	PLUG. VALVE	1
54	740A17	MUFFLER	1
55	P-321	RING RETAINING	1
56	P-838**	O-RING. DISOGRIN	2
57	P-115	RING. BACK-UP	2
58	P-889	O-RING	1
59	740B13	PLUG. PACKING	1
60	P-909	RING. BACK-UP	2
61	P-887	RING. QUAD	1
62	744-095*	WASHER (inc w/Air Piston)	1
63	744-094	PISTON. AIR	1
64	P-1392	NUT. CONELOK. 5/16-18	1
65	P-890	O-RING	1
66	740C4	BASE. HANDLE	1
67	P-886	RING. RETAINING	1
68	740B5	COVER. BASE	1
69	P-884	RING. RETAINING	1
70	530A34	SWIVEL	1
71	P-195	O-RING	2
72	530A35	BOLT. SWIVEL	1
73	P-1505	PRESSURE REGULATOR	1
74	P-832**	O-RING. DISOGRIN	1
75	700A22	GASKET	1
76	P-73	SCREW, SOC HD CAP. 10-24 x 5/8	4

\* NOT SOLD SEPARATELY

\*\*NO SUBSTITUTIONS

**EXPLODED VIEW OF G84**

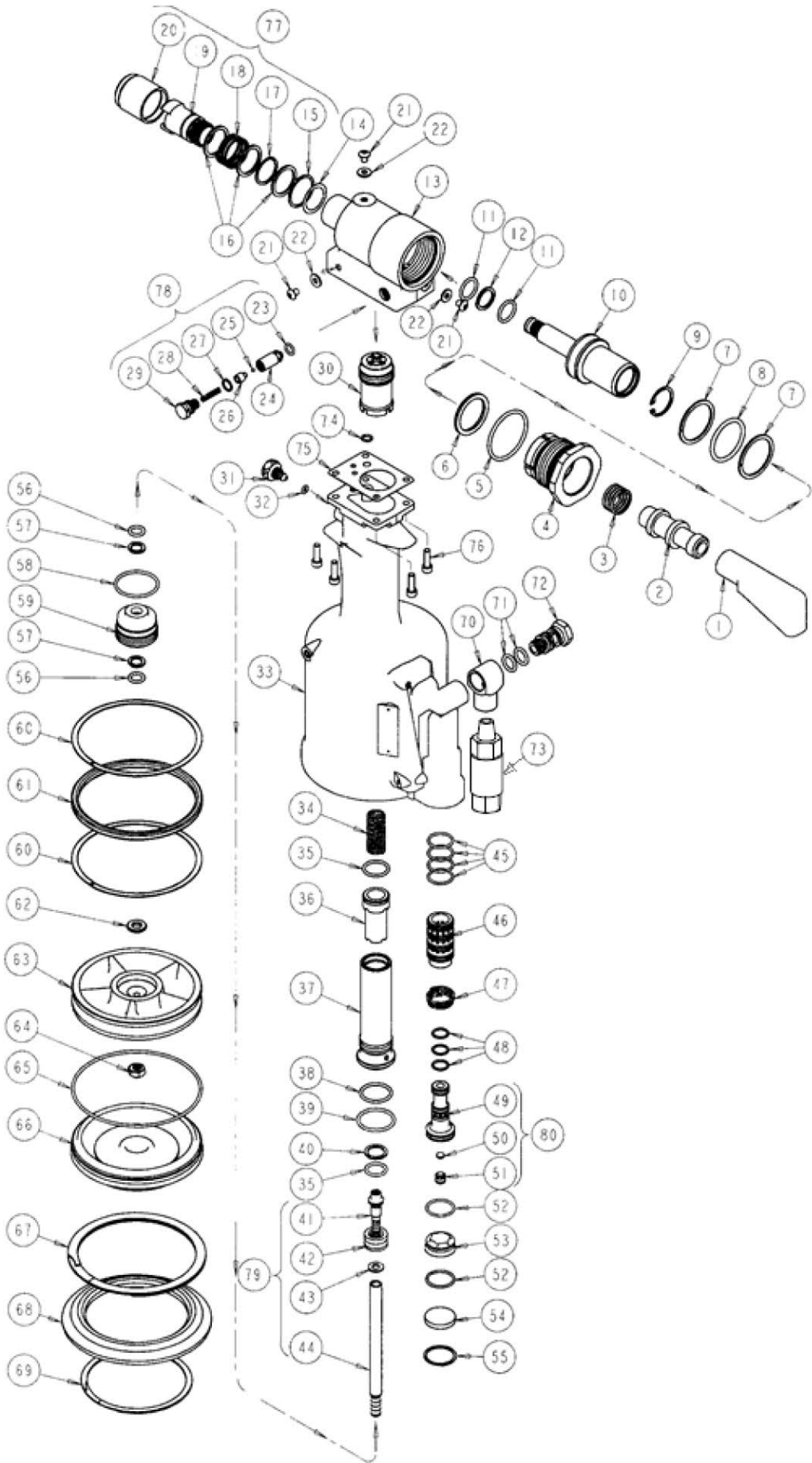



## Declaration of Conformity

We, **Cherry Aerospace**

Located at **1224 East Warner Avenue, Santa Ana, CA 92705-0157, USA,**

In accordance with the provisions of

### **Machine Directive 2006/42/EC**

Hereby declare under our sole responsibility that:

Equipment: Pneumatic Hydraulic Hand Riveter

**Model Number: G-84**

Serial Number: \_\_\_\_\_

Is in conformity with the applicable requirements of the following standards:

- EN ISO 12100:2010 Safety of Machinery; General Principles for design; Risk Assessment and Reduction
- ISO/TR 14121-1&2:2007 Safety of Machinery, Risk assessment
- EN 792-1:2000 + A1:2008 Safety requirements; Assembly power tools for non-threaded mechanical fasteners
- ISO 8662-11 Hand-held portable power tools -- Measurement of vibrations at the handle
- ISO 3744 Acoustics – Determination of sound power levels of noise sources
- ISO 4413:2010. Hydraulic fluid power - General Rules of safety
- ISO 4414:2010. Pneumatic fluid power - General Rules of safety

Signed by  \_\_\_\_\_

Cris Cobzaru,

Master of Science in Mechanical Engineering

Sr. Technical Services / Installation Tooling Engineer

**The Technical documentation for the machinery is available from:**

**Name: Karl-Heinz Beckers**

Position: CE Representative and Western Europe Sales Manager

Address: Maternusstrasse 14, D-52538, Gangelt, Germany

Mobile Phone +49 –(0) 171 31 88020