



ORIGINAL INSTRUCTIONS

G87D

NSN 5130-00-760-1360

Lockbolt® Power Tool

 **Instruction Manual** 
Pass on to user to read and keep for reference

M
A
N
U
A
L



CHERRY®
AEROSPACE



Aerospace

THE G87D TOOL

TABLE OF CONTENTS

Description 2

Specifications 2

Safety Warnings 2

Putting the tool in service 3

How to Use the G87D 3

Maintenance and Repair 4

Fill and Bleed Instructions 4

Troubleshooting Guide 5

Overhaul 5

 Air Valve 6

 Head Sub-Assembly 6

 Handle Sub-Assembly 6

Cross Section Drawing..... 7

Parts List 8

Exploded View 9

Pulling Heads 10

Declaration of Conformity Back Cover

WARRANTY

Seller warrants the goods conform to applicable specifications and drawings and will be manufactured and inspected according to generally accepted practices of companies manufacturing industrial or aerospace fasteners. In the event of any breach of the foregoing warranty, Buyer's sole remedy shall be to return defective goods (after receiving authorization from Seller) for replacement or refund of the purchase price, at the Seller's option. Seller agrees to any freight costs in connection with the return of any defective goods, but any costs relating to removal of the defective or nonconforming goods or installation of replacement goods shall be Buyer's responsibility. SELLER'S WARRANTY DOES NOT APPLY WHEN ANY PHYSICAL OR CHEMICAL CHANGE IN THE FORM OF THE PRODUCT IS MADE BY BUYER.

THE FOREGOING EXPRESS WARRANTY AND REMEDY ARE EXCLUSIVE AND ARE IN LIEU OF ALL OTHER WARRANTIES AND REMEDIES; ANY IMPLIED WARRANTY AS TO QUALITY, FITNESS FOR PURPOSE, OR MERCHANTABILITY IS HEREBY SPECIFICALLY DISCLAIMED AND EXCLUDED BY SELLER. THIS WARRANTY IS VOID IF SELLER IS NOT NOTIFIED IN WRITING OF ANY REJECTION OF THE GOODS WITHIN ONE (1) YEAR AFTER INITIAL USE BY BUYER OF ANY POWER RIVETER OR NINETY (90) DAYS AFTER INITIAL USE OF ANY OTHER PRODUCT.

Seller shall not be liable under any circumstances for incidental, special or consequential damages arising in whole or in part from any breach by Seller, AND SUCH INCID

For more information please contact our Technical Services Department at Tel. 714-850-6022

LOCTITE® is a registered trademark of Henkel Corporation
DEXRON® is a registered trademark of GM corporation.
PARKER® is a trademark of Parker Hannifin Corporation
LUBRRIPATE® is a trademark of Fiske Brothers Refining Co.

USATCO U.S. Air Tool Company, Inc.

Info@usatco.com

Eastern Division60 Fleetwood Ct, Ronkonkoma, NY 11779-6907 tel: (631) 471-3300 fax: (631) 471-3308
Western Division1219 W. Mahalo Place, Rancho Dominguez, CA 90220-5446 tel: (310) 632-5400 fax: (310) 632-3900

Aerospace

DESCRIPTION

The Cherry G87D pneumatic-hydraulic Lockbolt® Installation Tool is a heavy duty production tool designed for high-speed reliable installation of the most popular sizes of aircraft lock-bolts.

This powerful tool, designed with many ergonomic features weighs only 10-3/4 lbs. (4.875 kg.) and fits comfortably in the operator's hand. By bending the rubber pin deflector (1) sideways, 1-1/2" additional clearance can be obtained.

This tool can also be used to install blind bolts and other fastener types by using the appropriate pulling heads.

SPECIFICATIONS FOR G87D

The Cherry Aerospace® (CHERRY®) policy is one of continuous development. Specifications shown in this document may be subject to changes which may be introduced after publication. For the latest information always consult us.

AIR PRESSURE	90 PSI (6.2 bar) Min. / 110 PSI (7.6 bar) Max.
STROKE	9/16 inch (14.3 mm)
PULLING FORCE	9,500 lbs. (42.3 kN) @ 90 PSI (6,2 bar),
WEIGHT	10.75 lbs. (4,875 kg)
NOISE LEVEL	74.2 dB (A)
VIBRATION	less than 2.5 m/s ²
AIR CONSUMPTION	0.60 SCF/cycle (17 L/cycle)

SAFETY WARNINGS

- Do not use beyond the design intent; do not use substitute components for repair.
- Operating this tool with a damaged or missing stem deflector, or using the deflector as a handle, may result in severe personal injury. Rotate the pin deflector facing away from the operator
- Wear proper PPE when operating, repairing, or overhauling this tool (🧤👁️👂🛑)
- Any modification will void warranty and shall be at the customer's entire responsibility.
- Maintain the tool in a safe working condition at all times and examined at regular intervals for damage.
- Before disassembling the tool for repair, refer to the maintenance instructions. All repairs shall be undertaken only by personnel trained in Cherry installation tools.
- Disconnect the air line from the tool inlet before servicing, adjusting, fitting or removing any accessory.
- Ensure that the vent holes do not become blocked or clogged and the hoses are in good condition.
- Wash thoroughly after handling the fluid; excessive contact could cause rashes.
- Operating air pressure not to exceed 110 psi (7.6 bar); use of a pre-set regulator (P-1505) is recommended
- Do not operate the tool without the pulling head in place.
- All retaining rings, screwed end caps, air fittings, trigger valves and pulling heads should be attached securely and examined at the end of each working shift.
- Do not pull rivet in the air or directed at any person.
- Do not pound on the rear of the tool head to force rivets into holes as this will damage the tool.
- Safety warnings must be explained all operators as part of training.

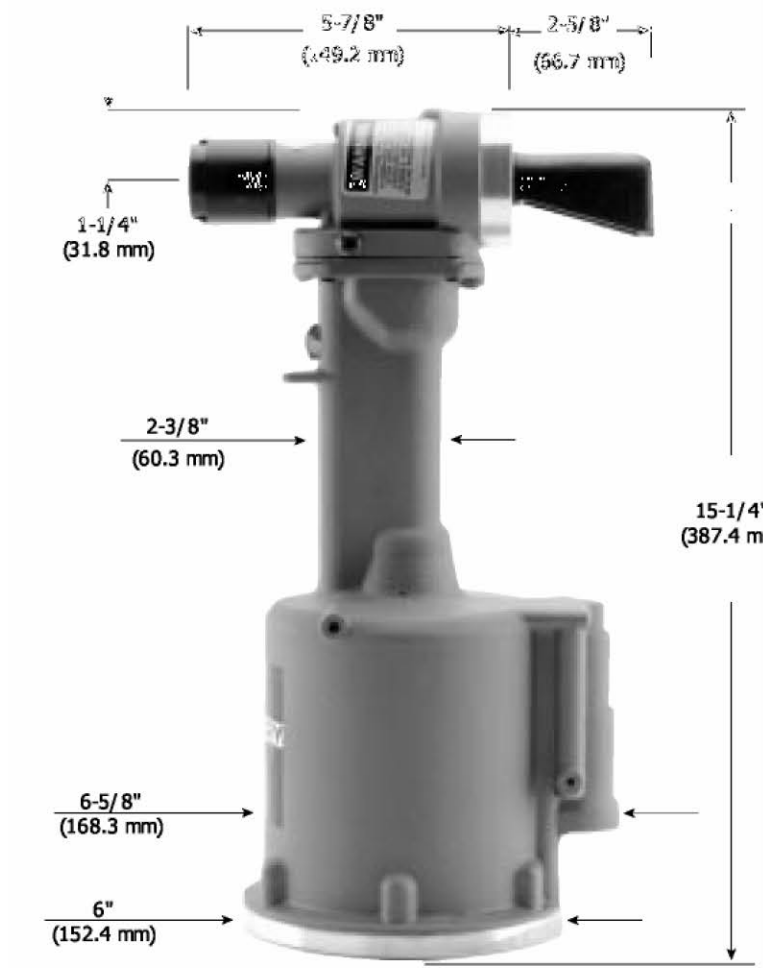

Aerospace

PUTTING THE TOOL IN SERVICE

The tool must be used with an air pressure regulator. Even if your shop air pressure is below the maximum recommended range, pressure spikes in your airlines could cause serious damage to the tool or cause safety concerns.

Tools with an integral Air Pressure Regulator (P-1505), may be attached to any shop airline.

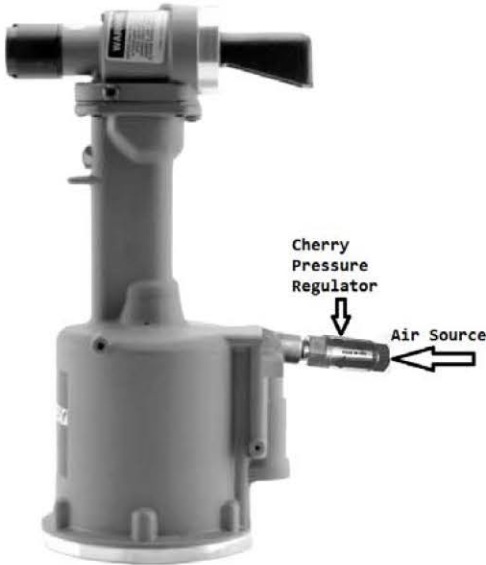

USATCO U.S. Air Tool Company, Inc.

Info@usatco.com

Eastern Division60 Fleetwood Ct., Ronkonkoma, NY 11779-6907 tel: (631) 471-3300 fax: (631) 471-3308
 Western Division1219 W. Mahalo Place, Rancho Dominguez, CA 90220-5446 tel: (310) 632-5400 fax: (310) 632-3900

Aerospace



HOW TO USE THE G87D



LOCKBOLT INSTALLATION

After selecting the proper pulling head and attaching it securely to the G84, connect the air line to the tool.

FOR LOCKBOLTS: Place the lockbolt pin into the workpiece and place the collar over the pintail.

While holding the back end of the lockbolt in place, push the pulling head onto the serrated area of the stem.

- Caution:** When using a non-self-releasing pulling head once the tool is placed onto the serrated end, it cannot be removed unless going through the installation cycle which breaks the serrated end of the bolt. The broken part (pintail) will eject through the rear of the riveter when using a straight pulling head and through the rear of the active area of the tool for when using offset pulling heads.

If the tool does not release the swaged collar after installation, it can be adjusted by adding shims behind the pulling head collet. If the tool still does not release, see troubleshooting instructions on page: See pulling head installation instructions.

BLIND BOLTS AND RIVETS

- Insert the rivet into the application, place the riveter over the serrated stem and pull the trigger to activate the tool. Upon release of the trigger, the stem will eject to the rear of the riveter when using straight pulling heads, and from the rear of the active area of the tool when using offset pulling head. Right angle pulling heads eject the stems through the front.

USATCO U.S. Air Tool Company, Inc.

Info@usatco.com

Eastern Division60 Fleetwood Ct, Ronkonkoma, NY 11779-6907 tel: (631) 471-3300 fax: (631) 471-3308
 Western Division1219 W. Mahalo Place, Rancho Dominguez, CA 90220-5446 tel: (310) 632-5400 fax: (310) 632-3900

Aerospace

MAINTENANCE AND REPAIR

This riveter has been manufactured to give maximum service with minimum care. For optimum function:



1. The hydraulic system to be full of oil and free from air at all times.
2. Use clean and dry air to prevent premature wear and clogging of the air components.
3. Inspect the riveter for fluid leaks routinely

Use automatic transmission fluid (ATF) type "A" (no substitutes). Cherry® Aerospace recommends using, Dexron® III ATF.

FIRST AID

Skin: Wash thoroughly with soap and water as soon as possible. Casual contact requires no immediate attention. If irritation develops, consult a physician.

Ingestion: Seek medical attention immediately. **DO NOT INDUCE VOMITING.**

Eyes: Flush with copious amounts of water. If irritation develops, consult a physician.

Inhalation: No significant adverse health effects are expected to occur on short term exposure. Remove from contaminated area. Apply artificial respiration if needed. If unconscious, consult physician.

FIRE

Suitable extinguishing media: CO2, dry powder, foam or water fog. **DO NOT** use water jets.

ENVIRONMENT

Waste Disposal: In accordance with local, state and federal regulations.

Spillage: Prevent entry into drains, sewers and water courses. Soak up with diatomaceous earth or other inert material.

Store the spent fluid in appropriate containers for disposal.

HANDLING

Eye protection required. Protective gloves recommended. Chemically resistant boots and apron recommended. Use in well-ventilated area.

COMBUSTIBILITY

It is slightly combustible when heated above flash point. It will release flammable vapors which can burn in open or be explosive in confined spaces if exposed to source of ignition.

STORAGE

Avoid storage near open flame or other sources of ignition.

PROPERTIES

<i>Specific gravity</i>	0.863
<i>Weight per gallon</i>	7.18 lbs.
<i>Open flash point</i>	>200°C (392°F)

FILL AND BLEED INSTRUCTIONS

Priming the tool- After service or overhauling, the riveter needs to be primed with fluid.

What is needed: a 1/8" Allen Wrench; the 700A77 Bleed Bottle with adaptor 700A86

-After completing the assembly of the Handle Subassembly (744-091),

Air Bleeding (air removal and fluid refill)

What is needed:, a 1/8" Allen Wrench; the 700A77 Bleed Bottle with adaptor 700A86

- Remove screw 29 and attach the bleed bottle bottom up (see picture). Cycle several times until no more bubbles surface inside of bottle. When the tool is being primed, make sure to cycle enough times to properly



TROUBLESHOOTING GUIDE

PROBLEM	POSSIBLE REASONS / SOLUTIONS
Piston does not move after depressing Trigger	- No air supply is connected: Connect to a clean, filtered air source at 90 to 110 psi (6,2 to 7,6 bar).
	- Faulty trigger: Remove and replace trigger assembly.
	- Broken power piston: Service the Handle Subassembly.
Short stroke or low pull force	- Significant fluid loss: Bleed the system to purge the air out. If performance doesn't improve, or excessive leakage continues, see below.
Head Cylinder Fluid leakage	- Leaks around the seals or fittings indicate that they are not tightened to seal properly: Tighten until no more leaks are observed.
	- Leaks at the front or back of head cylinder indicate worn/ damaged seals Service head cylinder per instructions provided herein
Air leakage at the spool valve	- Broken or dislodged valve spring.
	- Worn or damaged valve spool seals: Disassemble and service air valve per Air Sub-Assembly Overhaul Instructions.
Head piston is slow or seizes	- Piston or seal damage: Service head cylinder.
	- Oil bypassing due to power piston displacement off its seat: Service Handle Subassembly per instructions provided below.
	- Clogged air muffler or filter Clean thoroughly with solvent and back-blow with compressed air.
Head Piston (64) does not return fully forward even after system bleeding	- Pressure relief valve (85) malfunction: Remove head assembly and items 22 through 27. Clean thoroughly and reassemble; these items may need replacement.
	- Return Cylinder Spring (31) is damaged or broken: Remove head sub-assy and replace the damaged spring. Re-assemble, fill and bleed per page 5.



TOOL OVERHAUL

Tool overhaul is needed in case of tool malfunction, massive fluid loss or as part of your routine maintenance program.

- Tools needed:
 - **G85KT** – tool kit,
 - **Needle Nose Pliers**,
 - Replacement parts:
 - **G85D/G87D-KS** – service kit:
- Not shown, but included in the tool kit:
836B530 Valve Spring Installation Tool,
837B530 Valve Sleeve Removal Tool.

THE G85KT TOOL KIT

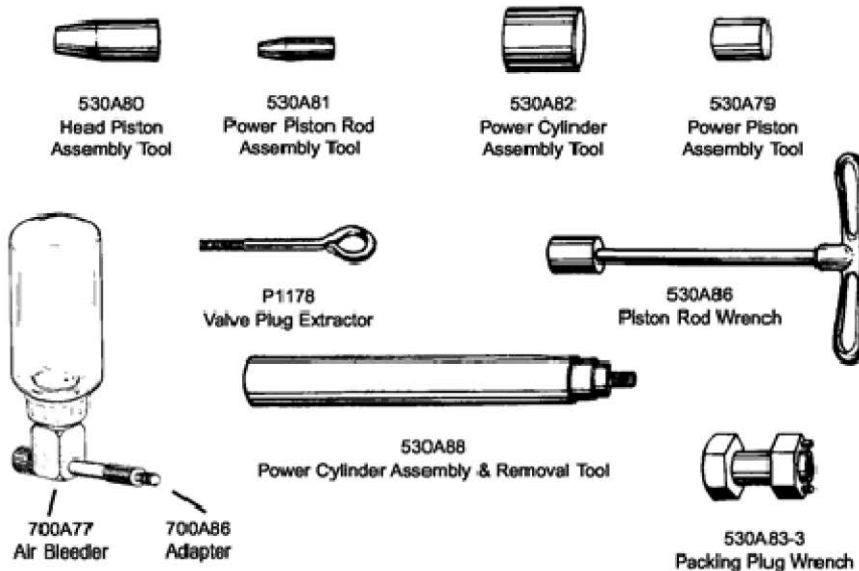

Aerospace

AIR VALVE

Disassembly Instructions:

- Remove retaining ring (62) and muffler (61).
- Insert the valve plug extractor P1178 into the end of valve plug (59) and pull it out.
- Pull out the valve spool subassembly (83) the same way.
- **Note:** In the unlikely event the valve sleeve (52) is irreversibly clogged, remove it as follows:
 - Grab one end of spring (49) with needle-nose pliers and turn/pull to dislodge it from its groove
 - After spring removal, pull out the valve sleeve (52) by using the removal tool 837B530.

Assembly Instructions: Reverse the above procedures; after replacement, lubricate all seals before re-assembling.

Caution: Install valve sleeve (47) carefully with your fingers: gently push and wiggle it to allow O-rings to slip in. Install spring (49); use tool 837B530 to push it firmly into the groove.

Make sure the Retaining Ring is snapped in securely to avoid a hazardous condition.

HEAD SUB-ASSEMBLY

Disassembly Instructions:

- Remove the pulling head and disconnect tool from air hose.
- Remove the screws adjoining the head to the handle (5); drain the fluid into a pan and dispose of it according to regulations.
- Remove the screws (5) adjoining head cap (6) to the Head Assembly; pull the piston out with the help of tool 530A80
- Remove the seals and back-up rings using a bent hook.
- Remove the pressure relief valve sub-assembly (22) through (27) from the head cylinder (14).
- Carefully unscrew the ball seat (23) from the head cylinder (14); if damaged, replace. Clean all parts and dry thoroughly.

Assembly Instructions: Reverse the above procedures; after replacement, lubricate all seals before re-assembling.

- To prime the system, fill the handle (42) just before replacing the head sub-assembly onto the handle.
- Tighten the six socket-head cap screws (5) uniformly to prevent leakage around the gasket (39).
- Bleed per instructions on page 4.

HANDLE SUB-ASSEMBLY

Disassembly Instructions:

- Remove the screws adjoining the head to the handle (5); drain the fluid into a pan and dispose of it according to regulations.
- Remove the screws (78) from bottom of base and pry the handle base (77) carefully out, using a screwdriver
- Remove the cotter pin (74); remove nut (73) with the help 9/16" socket wrench, while holding the power piston assembly (84) with wrench 530A86.
- Pull the air piston (71) out of the base with tool 530A88
- Push the power piston assembly (84) out through top by pushing it with tool 530A81 from the bottom.
- Remove the packing plug (68) with tool 530A83-and a 1-1/16" socket wrench
- Insert Tool 530A88 into top end of the power cylinder (43) and force it out of bottom of tool.
- Remove and replace all seals, back-up rings and gaskets; lubricate moving parts.
- To re-assemble, reverse the above instructions, using the appropriate tools.
- Tighten the slotted nut (73) at a torque around 50 - 59 Lb-in. (5.65 - 6.67 N-m)

Aerospace

G87D CROSS SECTION

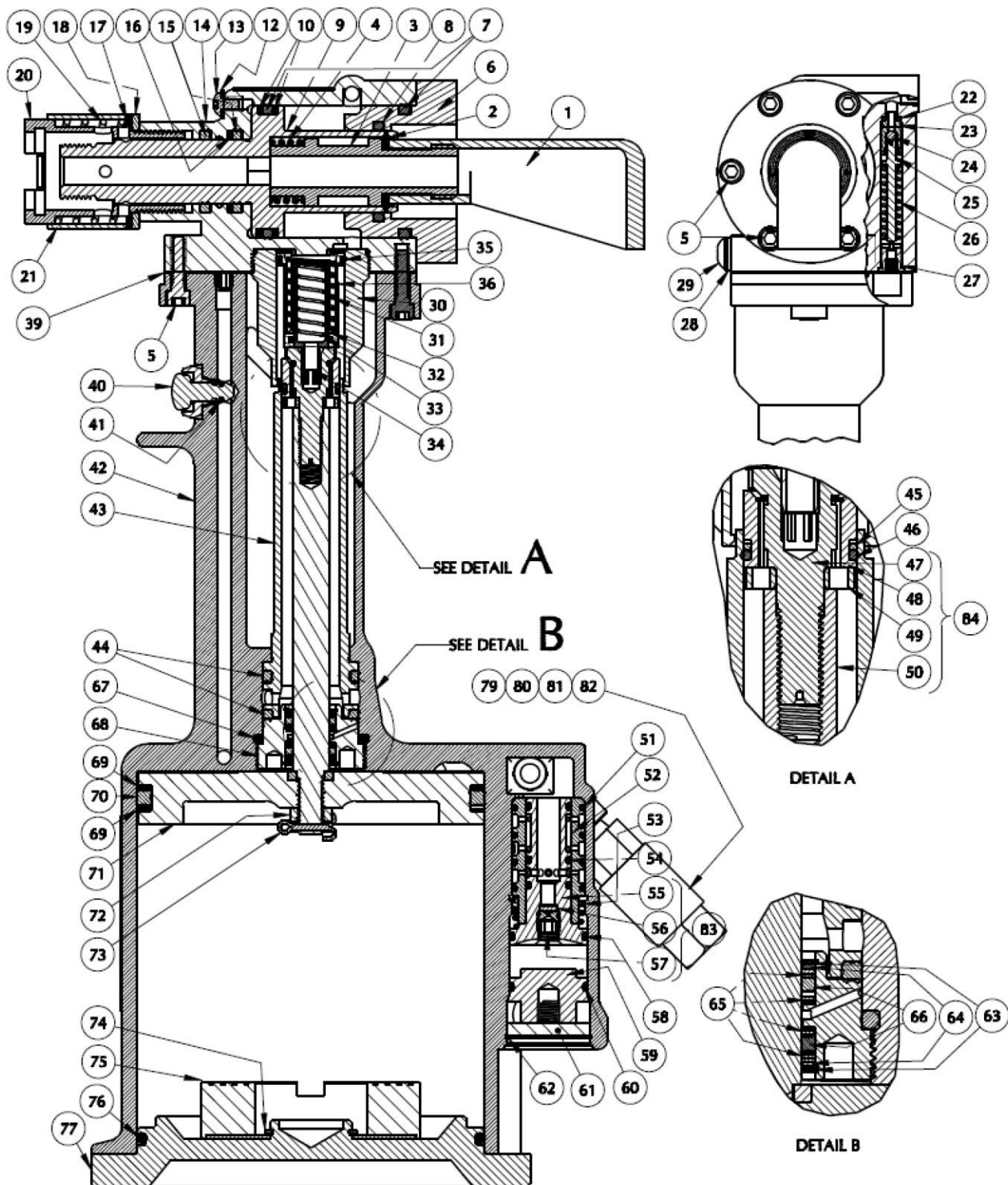

PART LIST FOR THE G87D (560D1C) RIVETER ASSEMBLY

ITEM NO	PART NO	DESCRIPTION	QTY
560C 139 HEAD SUB-ASSEMBLY			
1	530A 16	DEFLECTOR, PIN	1
2	P-300	RING, RETAINING (INT., 0.938 DIA.)	1
3	560A 17	FITTING, DEFLECTOR	1
4	530A20-1	SPRING	1
5	P-64	SOCKET. HD. CAP SCREW	12
6	560B7	CAP	1
7	P-221	QUAD RING (1762, 1484, .139)	2
8	P-299	O-RING (1387, 1.109, .139)	1
9	560B4	PISTON, HEAD	1
10	P-212	RING, BACK-UP (1742, 1500, .121)	2
11	P-370	SEAL PLUG, 1/16-27 NPTF	1
12	P-693	STAT-O-SEAL (.385, .164, .110)	1
13	P-413	SCREW, BUTTON HD. CAP, 8-32 X 1/4	1
14	530C2B	HEAD	1
15	P-217	QUAD RING (1137, .859, .139)	2
16	P-210	BACK-UP RING (1117, .875, .121)	1
* BAYONETTE MOUNT ASSEMBLY			
17	530A6	LOCKING SLEEVE	1
18	530A5	HEAD EXT ENSION	1
19	530A42	SPRING, LOCKING	1
20	P-236	RETAINING RING (INT. 1.456 DIA.)	1
21	530A40	THRUST WASHER	1
22	P-595	O-RING (.254, .114, .070)	1
23	530A22-2	VALVE SEAT	1
24	P-164	STEEL BALL, 1/8 DIA.	1
25	530A47	SPRING GUIDE	1
26	530A20-3	SPRING	1
27	530A48	PLUG, 5/16-24	1
28	530A21-1	WASHER	1
29	P-225	BUTTON HD SCREW, 1/4-20 X 3/8	1
30	560A9B	CYLINDER, RETURN	1
31	560A55	SPRING	1
32	560A54	HOLDER, SPRING	1
33	560A56	SPRING	1
34	560A53	PISTON, INNER	1
35	P-269	O-RING (.941, .801, .070)	1
36	560B52	PISTON, RETURN	1
37	P-298	O-RING (.566, .426, .070)	1
38	P-194	O-RING (.441, .301, .070)	1
39	530B8	HEAD GASKET	1

ITEM NO	PART NO	DESCRIPTION	QTY
560D 147 HANDLE SUB-ASSEMBLY			
40	703A33	TRIGGER ASSEMBLY (INCLUDES P-223)	1
	41 P-223	O-RING (.285, .145, .070)	1
42	530R 140	HANDLE	1
43	560A 13B	POWER CYLINDER	1
44	P-218	QUAD RING (1324, 1046, .139)	2
45	P-270	BACK-UP RING (.776, .670, .053)	1
46	P-268	O-RING (.816, .676, .070)	1
84	560A60	PISTON ROD ASSEMBLY	1
	47 560A65**	CAP, PISTON ROD	1
	48 560A64**	PISTON, POWER	1
	49 560A63**	STOP, PISTON	1
	50 560A61**	ROD, POWER PISTON	1
51	P-848	O-RING (.941, .801, .070)	4
52	530B 179	VALVE SPOOL	1
53	530A 178	SPRING	1
54	P-701	O-RING (.629, .489, .070)	3
83	530B 143	VALVE SPOOL ASSEMBLY	1
	55 530B 143-1**	SPOOL, VALVE	1
	56 700A 18**	FILTER	1
	57 700A69**	METERING SET SCREW	1
58	P-244	O-RING (1.066, .926, .070)	1
59	530A 144	PLUG	1
60	P-723	O-RING, 90 SHORE A	1
61	530A 145	MUFFLER	1
62	P-699	RETAINING RING (INT. 1.125 DIA.)	1
63	P-204	RETAINING RING (INT. .687 DIA.)	2
64	530A21-3	WASHER	2
65	P-213	BACK-UP RING (.676, .500, .088)	1
66	P-215	QUAD RING (.693, .487, .103)	2
67	P-196	O-RING (1.574, 1.296, .139)	1
68	530B 14	PACKING PLUG	1
69	P-214	BACK-UP RING (4.745, 4.375, .185)	2
70	P-222	QUAD RING (4.770, 4.350, .210)	1
71	530B 15	AIR PISTON	1
72	P-302	SLOTTED NUT 3/8-16	1
73	P-301	COTTER PIN, 3/32 DIA. X 3/4	1
74	P-537	RETAINING RING (EXT. 1.125 DIA.)	1
75	530B92	BONDED CUSHION	1
76	P-197	O-RING (4.762, 4.484, .139)	1
77	530C 141	BASE HANDLE	1
78	P-700	SCREW, CAP, FLAT HD, 5/16-18 X 1	6
79	530A34	SWIVEL	1
80	P-195	O-RING (.630, .424, .103)	2
81	530A35	SWIVEL BOLT	1
82	P-1505	PRESET PRESSURE REGULATOR	1

Shim 530A50 may be necessary to align the bayonette mount assembly as desired.

**Not sold separately

USATCO U.S. Air Tool Company, Inc.

Eastern Division60 Fleetwood Ct., Ronkonkoma, NY 11779-6907 tel: (631) 471-3300 fax: (631) 471-3308

Western Division1219 W. Mahalo Place, Rancho Dominguez, CA 90220-5446 tel: (310) 632-5400 fax: (310) 632-3900

Info@usatco.com

**G87D
EXPLODED
VIEW**

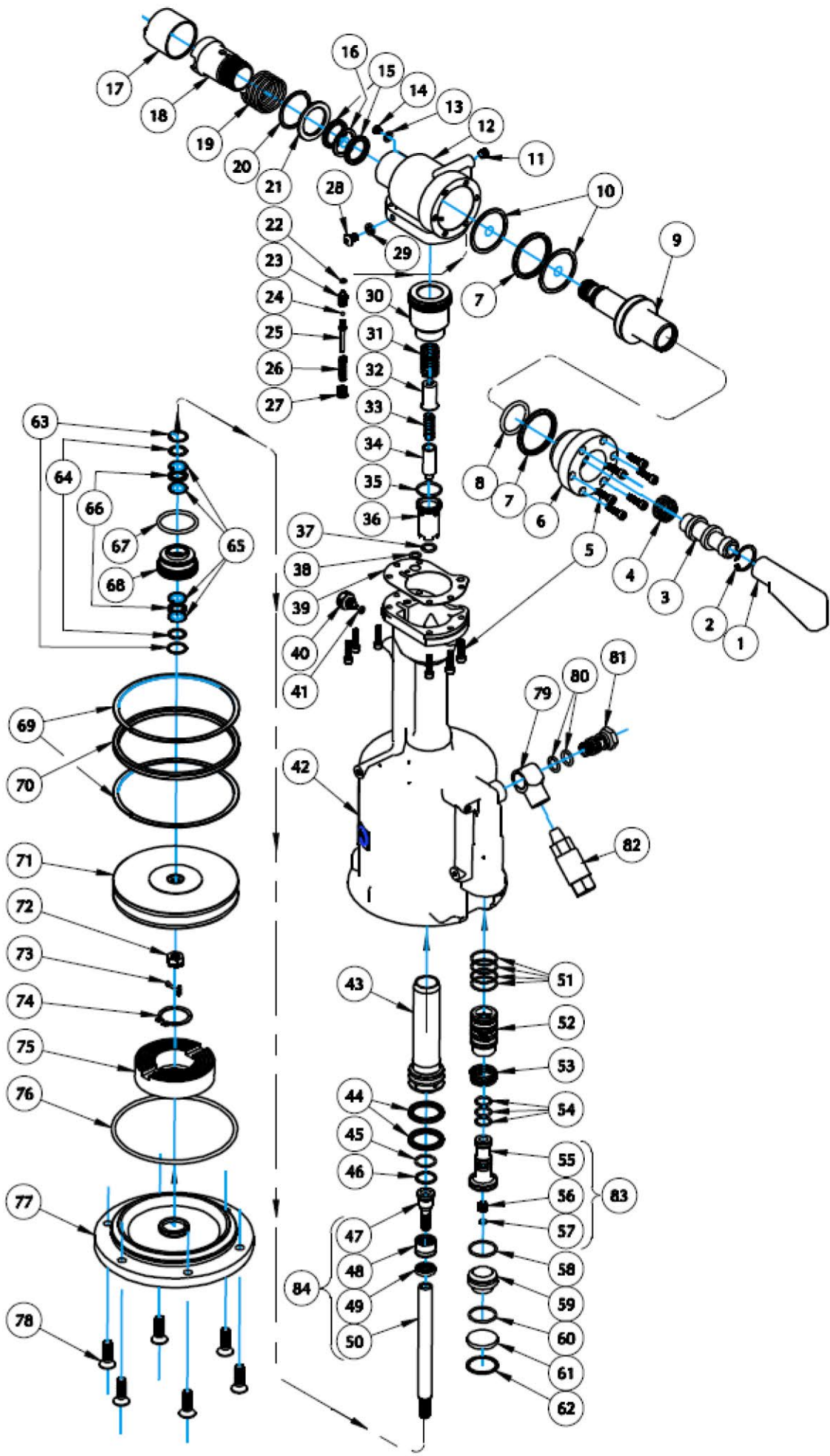

PULLING HEADS

NOSE ASSEMBLIES

Nose assemblies are not furnished and must be ordered separately. Make certain the nose assembly is kept clean as adhesives, chips, sealants, etc., will clog up the serrations of the jaws and may cause the stem to slip. Please refer to the pulling head charts below for the proper selection. All Huck pulling heads suitable for the 353 style tool will fit directly on this tool.

LOCKBOLT DIAMETER	LENGTH FROM TOOL FACE (EXCEPT COLUMN 3)	1. STRAIGHT NOSE			2. CHISEL NOSE	3. OFFSET
		SHORT PINTAIL	SWIVEL	SWIVEL SELF-RELEASING	SWIVEL SELF-RELEASING	
1/8"	2"	H513-04-20*	-	-	-	H563-4B*
	3-1/2"	H513-04-35*	-	-	-	H563SP-4B*
	6"	H513-04-60*	-	-	-	-
5/32"	2"	-	H513S-05-20*	H513SR-05-20*	H513SRC-05-20*	H563-5B*
	3-1/2"	H513-05-35*	H513S-05-35	H513SR-05-35	H513SRC-05-35*	H563SP-5B*
	6"	H513-05-60*	-	-	-	-
3/16"	2"	H513-06-20*	H513S-06-20*	H513S-06-20*	H513S-06-20*	H563-6B*
	2-3/8"	-	H513S-06-24	H513S-06-24	-	H562-6B
	3-1/2"	-	H513S-06-35*	H513S-06-35*	H513S-06-35*	H563SP-6B*
	4-13/16"	-	H513S-06-48	H513S-06-48	-	-
	6"	H513-06-60*	-	-	-	-
1/4"	2-3/8"	-	H513S-08-24	H513S-08-24	-	H562-8B
	3-1/2"	H513-08-35*	H513-08-35*	-	-	-
	4-13/16"	-	H513S-08-48	H513S-08-48	H513S-08-48	-
5/16"	2-11/16"	-	H513S-10-27	H513S-10-27	-	-
	4-3/16"	-	H513S-10-42	H513S-10-42	-	-
3/8"	2-11/16"	-	H513S-12-27	H513S-12-27	-	-
	4-3/16"	-	H513S-12-42	H513S-12-42	-	-

*These parts require the 552 adapter when used on Cherry G87D, G85D or Huck 353. Parts with an asterisk fit directly on the Cherry G83 or Huck 352 tools.

NOTES:

Parts with no asterisk fit directly on Cherry G87D, G85D and Huck 353 tools.

After the H513 in part numbers, S = Swivel, R = Self Releasing

C = Chisel Nose Straight Lockbolt pulling head part numbers

indicate pulling head length and diameter.

Example: In Part No. H513-05-35 the -05 indicates 5/32 diameter and -35 indicates that the pulling head extends 3-1/2" beyond gun line.

After H563, SP = Short Pintail

	PART NO.	CHERRYMAX	ADAPTER
OFFSET	H827-8	-8	560-070
RIGHTANGLE	H828-8	-8	560-070

	PART NO.	MAXIBOLT DIA.	ADAPTER
STRAIGHT PULLING HEADS	H652-8MB	-8	-
	H83-5MB	-5	552
	H83-6MB	-6	552
MAXIBOLT PULLING HEADS	H744-5MB	-5	560-070
	H744-6MB	-6	560-070
OFFSET	H856-6MB	-6	560-070
RIGHT ANGLE	H828-5MB	-5	560-070
	H828-6MB	-6	560-070
	H828-56MBP	-5 AND -6	560-070

CHERRYMAX® PULLING HEADS AND ADAPTER

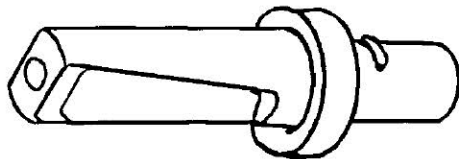

H513 STRAIGHT PULLING HEADS

The H513 series pulling heads are available to accommodate the 1/8" diameter through 3/8" diameter Lockbolts® in varying lengths. The pictured head assembly is swivel, self-releasing, chisel nose.

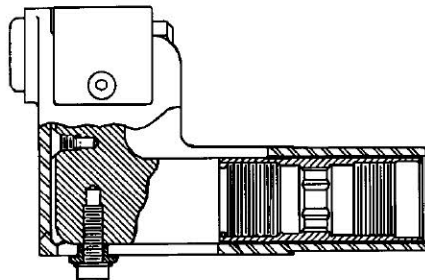

H562-6B LOCKBOLT® OFFSET PULLING HEAD

The offset nose assemblies permit the installation of the -6 and -8 diameter lockbolts in many applications that are inaccessible to a straight head. They are of heavy cast stainless steel construction with a replaceable insert anvil. See the "Tool Sheet" enclosed with the pulling head for instructions.



Declaration of Conformity

We, Cherry Aerospace

Located at 1224 East Warner Avenue, Santa Ana, CA 92705-0157, USA,

In accordance with the provisions of

Machine Directive 2006/42/EC

Hereby declare under our sole responsibility that:

Equipment: **Pneumatic Hydraulic Hand Riveter**

Model Number: **G87D**

Serial Number: _____

Is in conformity with the applicable requirements of the following standards:

EN ISO 12100:2010	Safety of Machinery; General Principles for design; Risk Assessment and Reduction
ISO/TR 14121-1&2:2007	Safety of Machinery, Risk assessment
EN 792-1:2000 + A1:2008	Safety requirements; Assembly power tools for non-threaded mechanical fasteners
ISO 8662-11	Hand-held portable power tools -- Measurement of vibrations at the handle
ISO 3744	Acoustics – Determination of sound power levels of noise sources
ISO 4413:2010.	Hydraulic fluid power - General Rules of safety
ISO 4414:2010.	Pneumatic fluid power - General Rules of safety

Signed by: _____

Cris Cobzaru,
Master of Science in Mechanical Engineering
Sr. Technical Services / Installation Tooling Engineer

The Technical documentation for the machinery is available from:

Name: Karl-Heinz Beckers

Position: CE Representative and Western Europe Sales Manager

Address: Maternusstrasse 14, D-52538, Gangelt, Germany

Mobile Phone +49 –(0) 171 31 88020