



20-128-4S

Snake Drill Attachment

Important

This snake drill attachment was produced entirely in the U.S.A., using the highest quality materials available. The following information is provided to help keep your tool in top condition. All attachments are right hand drive only. Maximum RPM 2,500. Do not force cutting action with dull tooling, abuse will ruin gears.

Lubrication

This tool is now greased with a quality gear lubricant (Dotco or equal). Lubricate gears and drive shaft occasionally to extend life of these parts.

Note: Angle head (index #1) and retainer bearing (index #7) are removed by turning right hand.

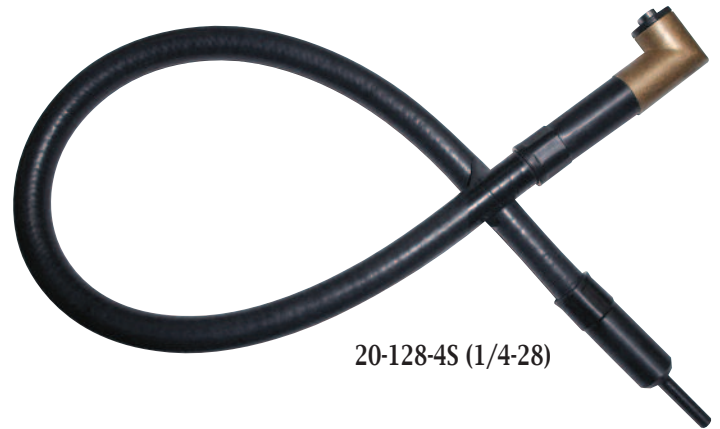

20-128-4S (1/4-28)

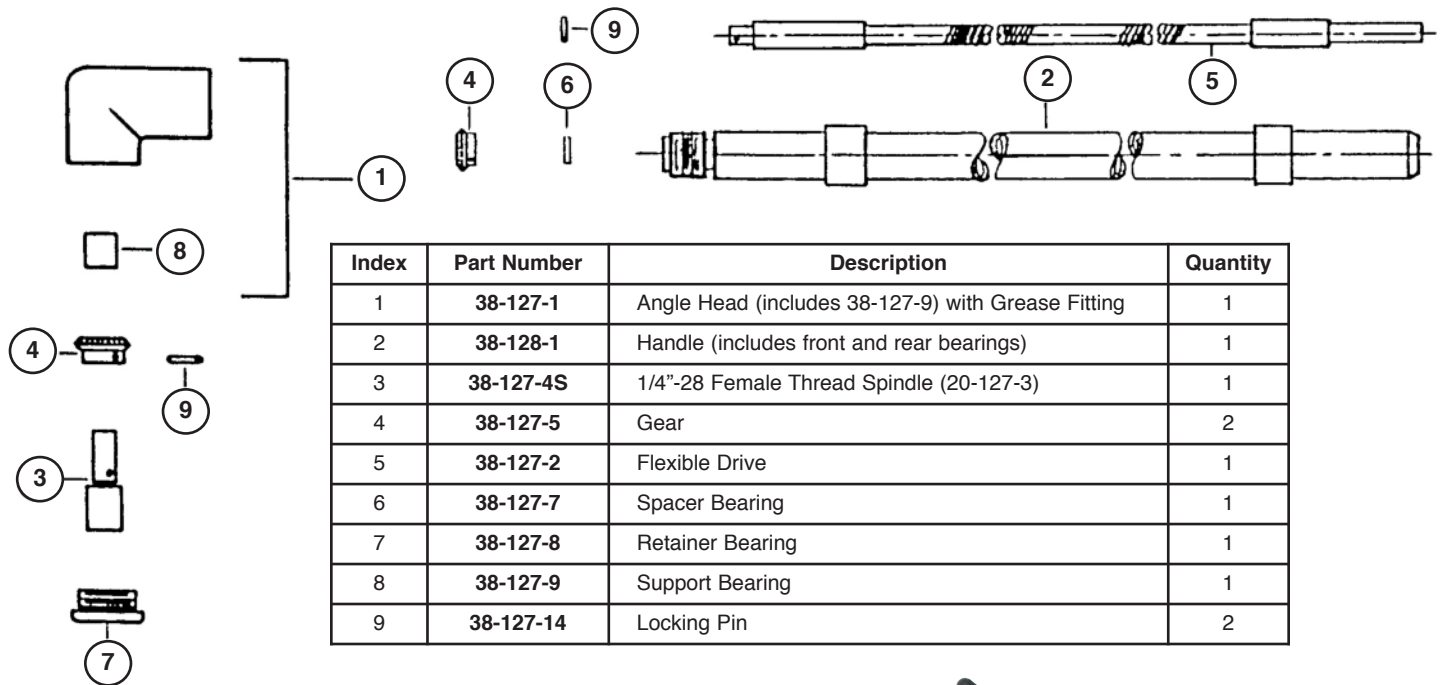

Also Available:

53-77 Angle Drill Conversion Assembly
 Convert any 1/4-28 angle or snake drill to convenient keyed chuck mode. Includes adapter & 5/32" capacity chuck with chuck key.



Toll Free Nationwide & Canada: **800-645-8180**

USATCO\U.S. AIR TOOL COMPANY, INC. www.USATCO.COM NEW YORK • CALIFORNIA

Rev0515

Threaded Shank Adapter Drills

High Speed Steel Adapter Drills

Drills are manufactured to NAS 965 Type 'B' construction with 135° split points. Great for drilling general to medium duty, low tensile strength materials in confined areas.

Cobalt Adapter Drills

Drills are manufactured to NAS 965 Type 'D' construction with 135° heavy duty split points and surface treated. Made from M42 8% cobalt high speed steel. Great for drilling hard, tough high tensile strength materials in confined areas. When drilling low tensile strength materials these drills will have a significantly greater tool life than standard H.S.S., resulting in a much lower cost per drill.



Note: Carbide drills, PCD drills, & custom drill sizes also available, please inquire.

Adapter Drills, 1/4"-28 Shank Thread							
Drill Size	Decimal Equivalent	H.S.S. Stubby 3/4" OAL	H.S.S. Short 1-1/4" OAL	H.S.S. Long 2-1/8" OAL	Cobalt Stubby 3/4" OAL	Cobalt Short 1-1/4" OAL	Cobalt Long 2-1/8" OAL
2.3 mm	.0906"	02-2924-2.3	02-2964-2.3	02-2974-2.3	02-2924-2.3C	02-2964-2.3C	02-2974-2.3C
3/32"	.0938"	02-2921-3/32	02-2961-3/32	02-2971-3/32	02-2921-3/32C	02-2961-3/32C	02-2971-3/32C
40	.0980"	02-2922-40	02-2962-40	02-2972-40	02-2922-40C	02-2962-40C	02-2972-40C
3.17 mm	.1248"	02-2924-3.17	02-2964-3.17	02-2974-3.17	02-2924-3.17C	02-2964-3.17C	02-2974-3.17C
1/8"	.1250"	02-2921-1/8	02-2961-1/8	02-2971-1/8	02-2921-1/8C	02-2961-1/8C	02-2971-1/8C
30	.1285"	02-2922-30	02-2962-30	02-2972-30	02-2922-30C	02-2962-30C	02-2972-30C
27	.1440"	02-2922-27	02-2962-27	02-2972-27	02-2922-27C	02-2962-27C	02-2972-27C
3.96 mm	.1559"	02-2924-3.96	02-2964-3.96	02-2974-3.96	02-2924-3.96C	02-2964-3.96C	02-2974-3.96C
5/32"	.1562"	02-2921-5/32	02-2961-5/32	02-2971-5/32	02-2921-5/32C	02-2961-5/32C	02-2971-5/32C
21	.1590"	02-2922-21	02-2962-21	02-2972-21	02-2922-21C	02-2962-21C	02-2972-21C
20	.1610"	02-2922-20	02-2962-20	02-2972-20	02-2922-20C	02-2962-20C	02-2972-20C
16	.1770"	02-2922-16	02-2962-16	02-2972-16	02-2922-16C	02-2962-16C	02-2972-16C
4.76 mm	.1874"	02-2924-4.76	02-2964-4.76	02-2974-4.76	02-2924-4.76C	02-2964-4.76C	02-2974-4.76C
3/16"	.1875"	02-2921-3/16	02-2961-3/16	02-2971-3/16	02-2921-3/16C	02-2961-3/16C	02-2971-3/16C
11	.1910"	02-2922-11	02-2962-11	02-2972-11	02-2922-11C	02-2962-11C	02-2972-11C
10	.1935"	02-2922-10	02-2962-10	02-2972-10	02-2922-10C	02-2962-10C	02-2972-10C
3	.2130"	02-2922-3	02-2962-3	02-2972-3	02-2922-3C	02-2962-3C	02-2972-3C
7/32"	.2188"	02-2921-7/32	02-2961-7/32	02-2971-7/32	02-2921-7/32C	02-2961-7/32C	02-2971-7/32C
D	.2460"	02-2923-D	02-2963-D	02-2973-D	02-2923-DC	02-2963-DC	02-2973-DC
1/4"	.2500"	02-2921-1/4	02-2961-1/4	02-2971-1/4	02-2921-1/4C	02-2961-1/4C	02-2971-1/4C
6.35 mm	.2500"	02-2924-6.35	02-2964-6.35	02-2974-6.35	02-2924-6.35C	02-2964-6.35C	02-2974-6.35C
F	.2570"	02-2923-F	02-2963-F	02-2973-F	02-2923-FC	02-2963-FC	02-2973-FC
G	.2610"	02-2923-G	02-2963-G	02-2973-G	02-2923-GC	02-2963-GC	02-2973-GC
17/64"	.2656"	02-2921-17/64	02-2961-17/64	02-2971-17/64	02-2921-17/64C	02-2961-17/64C	02-2971-17/64C
J	.2770"	02-2923-J	02-2963-J	02-2973-J	02-2923-JC	02-2963-JC	02-2973-JC
9/32"	.2812"	02-2921-9/32	02-2961-9/32	02-2971-9/32	02-2921-9/32C	02-2961-9/32C	02-2971-9/32C
5/16"	.3125"	02-2921-5/16	02-2961-5/16	02-2971-5/16	02-2921-5/16C	02-2961-5/16C	02-2971-5/16C
8 mm	.3150"	02-2924-8	02-2964-8	02-2974-8	02-2924-8C	02-2964-8C	02-2974-8C
3/8"	.3750"	02-2921-3/8	02-2961-3/8	02-2971-3/8	02-2921-3/8C	02-2961-3/8C	02-2971-3/8C

USATCO\U.S. Air Tool Company, Inc.

Eastern Division60 Fleetwood Ct., Ronkonkoma, NY 11779-6907 tel: (631) 471-3300 fax: (631) 471-3308

Western Division1219 W. Mahalo Place, Rancho Dominguez, CA 90220-5446 tel: (310) 632-5400 fax: (310) 632-3900