

700A77 CHERRY® AIR BLEEDER

INSTRUCTION SHEET



CHERRY®
AEROSPACE

PURPOSE

To keep Cherry® hydraulic riveters operating at peak efficiency, it is absolutely essential that the hydraulic systems be kept full of fluid and free of air.

Based on the same principle used in bleeding the hydraulic brake system of an automobile, the 700A77 Cherry Air Bleeder will quickly and easily remove all air and assure the complete filling of the system with hydraulic fluid. It may be used in the tool crib or right on the production line, since it requires but a few minutes to perform this vital function. The air bleeder is a small item, but does a really big job...it *prevents downtime*.

The bottle is molded from pure polycarbonate, the toughest of all thermoplastic materials, and is virtually unbreakable. All other components are precision machined for long life. Replacement parts may be obtained in case of loss or damage.

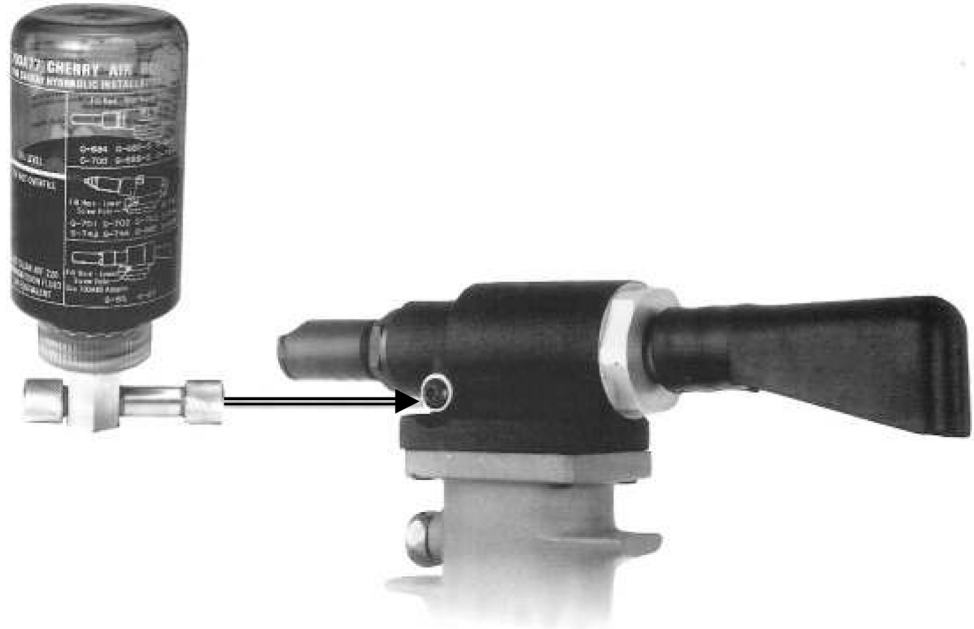

THE 700A77 CHERRY® AIR BLEEDER MAY BE USED ON ANY OF THE FOLLOWING RIVETERS

G85D	G87D
(Use 700A86 adapter, furnished on request)	

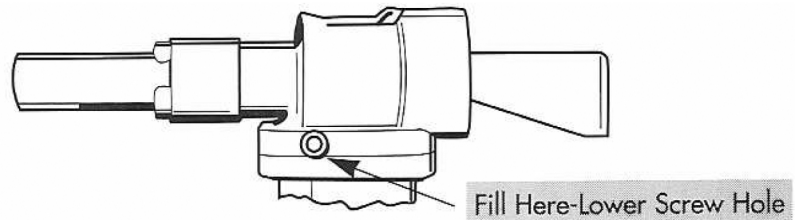

G684	G686B-S	G700
G685B-S	G689	G784

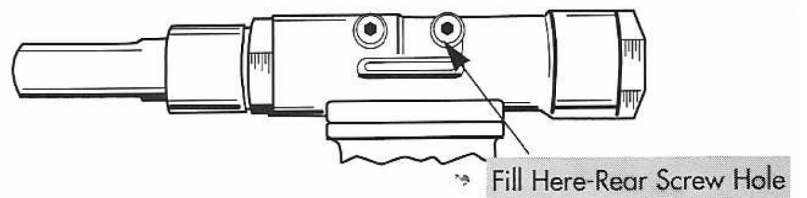

G701A	G702	G704B
G740A	G744	G746
G747	G83	G845
G846		

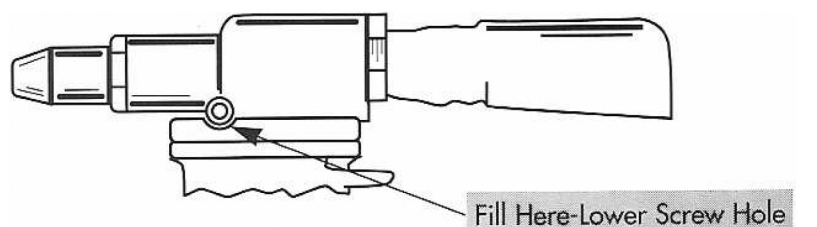

USATCO U.S. Air Tool Company, Inc.

Eastern Division60 Fleetwood Ct., Ronkonkoma, NY 11779-6907 tel: (631) 471-3300 fax: (631) 471-3308
Western Division1219 W. Mahalo Place, Rancho Dominguez, CA 90220-5446 tel: (310) 632-5400 fax: (310) 632-3900

700A77 CHERRY® AIR BLEEDER

INSTRUCTION SHEET



CHERRY®
AEROSPACE

OPERATING INSTRUCTIONS



1. Fill Air Bleeder bottle (10) to oil level line with clean, automatic transmission fluid (ATF)*.
2. Connect installation tool to air supply with a minimum of 90 psi pressure.
3. Refer to sketches on other side of this sheet and select correct filling screw hole. Remove that screw only.
4. Remove knob (9) from Air Bleeder valve and attach Air Bleeder to filler hole by turning knurled thumb screw (1). Make sure Stat-O-Seal washers are in place to prevent leakage.
5. With the riveter standing upright, turn Air Bleeder bottom side up as shown in photo.
6. Pull the riveter trigger, hold it for 2 or 3 seconds, and release. Wait 2 or 3 seconds and repeat. Do this about 20 times.
7. Observe action inside Air Bleeder. Initially, there will be some air bubbles vigorously emitted in the bottle, but as the procedure continues a noticeable "perking" of air-free oil will occur.
8. **Release trigger.** Remove Air Bleeder. Remove other screw from heat to permit any excess fluid to drain out. Wait about two minutes then replace both screws and washers, tightening them snugly.

* Cherry recommends using Mobil's Multi-Purpose, General Motors Dexron® or an equivalent ATF also may be used. **DO NOT USE ATF TYPE F.**

PARTS LIST

REF. NO.	PART NO.	DESCRIPTION	QTY.
1	700A90	Thumb Screw	1
2	P-572	Stat-O-Seal	3
3	P-899	Hex Nut	1
4	P-898	Steel Washer	1
5	700B84-2	Cap & Bottle	1
6	P-900	Seal Washer	1
7	700A89	Block	1
8	700A88	Sleeve	1
9	700A87	Knob	1
10	700B84-1	Bottle	1
11*	700A86	Adapter	1
12*	P-293	O-Ring	1

* Must be ordered separately for use with G85D and G87D

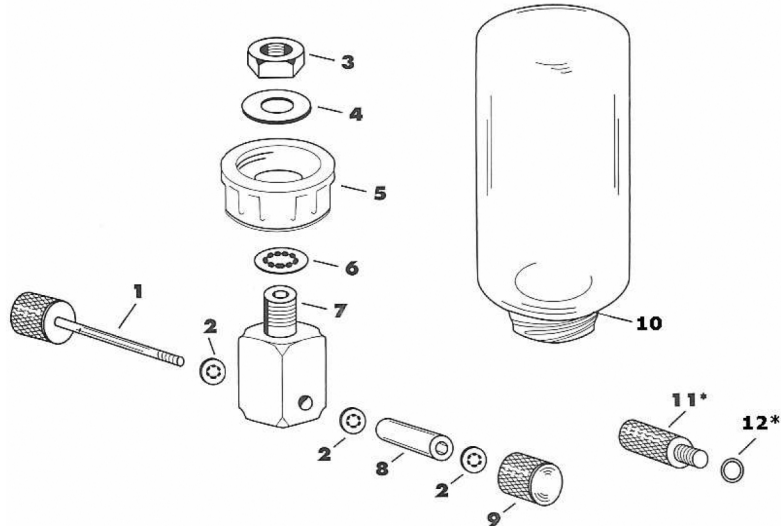

WARRANTY

Seller warrants the goods conform to applicable specifications and drawings and will be manufactured and inspected according to generally accepted practices of companies manufacturing industrial or aerospace fasteners. In the event of any breach of the foregoing warranty, Buyer's sole remedy shall be to return defective goods (after receiving authorization from Seller) for replacement or refund of the purchase price, at the Seller's option. Seller agrees to any freight costs in connection with the return of any defective goods, but any costs relating to removal of the defective or nonconforming goods or installation of replacement goods shall be Buyer's responsibility. SELLER'S WARRANTY DOES NOT APPLY WHEN ANY PHYSICAL OR CHEMICAL CHANGE IN THE FORM OF THE PRODUCT IS MADE BY BUYER. THE FOREGOING EXPRESS WARRANTY AND REMEDY ARE EXCLUSIVE AND ARE IN LIEU OF ALL OTHER WARRANTIES AND REMEDIES; ANY IMPLIED WARRANTY AS TO QUALITY, FITNESS FOR PURPOSE, OR MERCHANTABILITY IS HEREBY SPECIFICALLY DISCLAIMED AND EXCLUDED BY SELLER. This warranty is void if seller is not notified in writing of any rejection of the goods within ninety (90) days after receipt of the goods by buyer.

Seller shall not be liable under any circumstances for incidental, special or consequential damages arising in whole or in part from any breach by Seller, AND SUCH INCIDENTAL, SPECIAL, OR CONSEQUENTIAL DAMAGES ARE HEREBY EXPRESSLY EXCLUDED.

Our policy is one of continuous development. Specifications shown in this document may be subject to changes introduced after publication.

NOTE: The properties, strength, dimensions, installed characteristics and all other information in these materials are for guidance only to aid in the correct selection of the products described herein and is not intended or implied as part of the above warranty. All applications should be evaluated for functional stability and available samples of the described parts can be requested for installed tests, suitability and evaluations.

USATCO U.S. Air Tool Company, Inc.

Eastern Division60 Fleetwood Ct., Ronkonkoma, NY 11779-6907 tel: (631) 471-3300 fax: (631) 471-3308

Western Division1219 W. Mahalo Place, Rancho Dominguez, CA 90220-5446 tel: (310) 632-5400 fax: (310) 632-3900