

H753A-249NP

RIVETLESS NUT PLATE® RIGHT ANGLE PULLING HEAD

Technical Data Sheet, Page 1 of 2

DIMENSIONAL DATA

(see figure, all measurements in Inches)

- Tool weight (without riveter): 1.20 Lbs (0.540 Kg).

CHOICE OF RIVETERS

- **G704B** Cherry® Riveter
- **G800** Cherry® Hand Riveter

MOUNTING INSTRUCTIONS

- Attach riveter to air source for correct piston positioning; for hand powered riveters (G750A), make sure that the pressure has been released and that the correct adaptors are used.
- Push the collet bolt assembly forward (see Figure 1) before mounting.
- While holding collet bolt in a forward position, engage 1 or 2 threads of drawbolt (18) onto riveter head piston before threading adapter fitting (19) into end of riveter head cylinder; turn clockwise until snug.
- Rotate pulling head to desired position and tighten jam nut (20) to secure pulling head orientation.
- Cycle the tool to make sure it is functional.

USAGE

- The H753A-249NP pulling head will install Rivetless Nutplates for metallic structures in holes $\varnothing.249$ min.

BEFORE USE, MAKE SURE THAT:

- Proper air source is connected.
- The sleeve and pilot are in proper working condition; any sign of damage is an indication that components need to be replaced. No installations should be made if tooling is worn or damaged.

DURING OPERATION

- Inspect the active area of the sleeve and pilot regularly.
- Keep the tool clean, especially the pilot, sleeve and jaws; pay special attention when sealants are used.
- If stem slippage occurs, the jaws need to be either cleaned or replaced.

PREVENTATIVE MAINTENANCE

- Clean the sleeve, pilot, jaw set and collet every 1,000 installations or when failures occurs; use a wire brush to clean the copper deposited inside the jaw set.
- Lubricate outside of the jaw set with Lubriplate® or similar light lubricant.

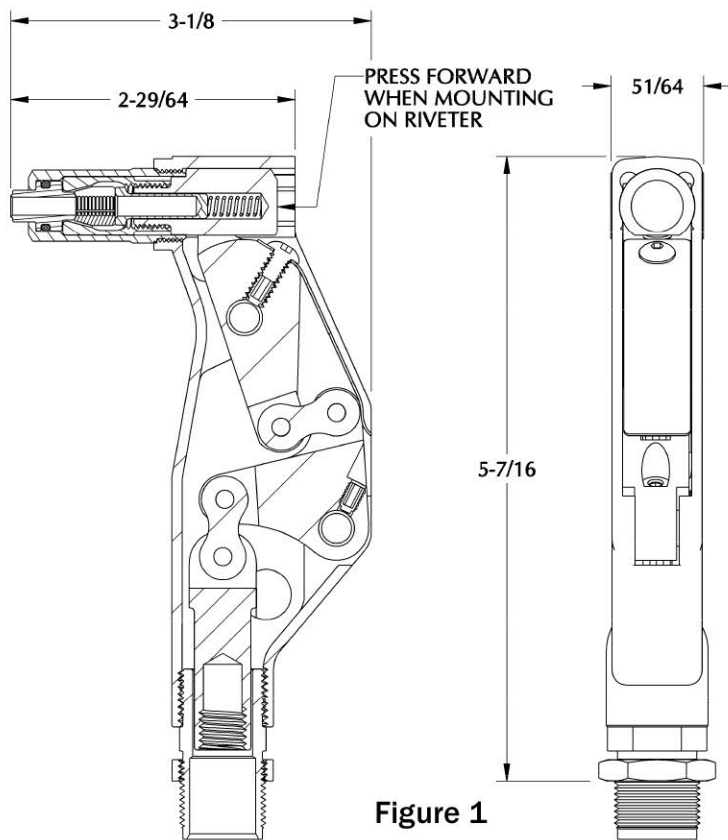

Figure 1

USATCO U.S. Air Tool Company, Inc.

Eastern Division60 Fleetwood Ct., Ronkonkoma, NY 11779-6907 tel: (631) 471-3300 fax: (631) 471-3308

Western Division1219 W. Mahalo Place, Rancho Dominguez, CA 90220-5446 tel: (310) 632-5400 fax: (310) 632-3900

Info@usatco.com

H753A-249NP

RIVETLESS NUT PLATE® RIGHT ANGLE PULLING HEAD



Technical Data Sheet, Page 2 of 2

PARTS LIST

20	671A16	JAM NUT	1
19	975-020	ADAPTER FITTING	1
18	975-021	DRAWBOLT	1
17	753A11	GUIDE PIN	1
16	753A9	LINK PIN	4
15	P-954	LINK	8
14	753B6	BELL CRANK	1
13	P-930	SET SCREW	2
12	753A10	PIVOT PIN	2
11	753B5	LEVER	1
10	753A16	GUARD	1
9	P-413	BUTTON HEAD SCREW	1
8	975-018	COLLET BOLT	1
7	P-1319	SPRING	1
6	975-017	JAW FOLLOWER	1
5	975-014	JAW SET	1
4	753A13A	COLLET	1
3	975-019	FRAME	1
2	975-046	PILOT INSERT	1
1	975-045	SLEEVE	1
ITEM No.	PART NUMBER	DESCRIPTION	QTY. PER

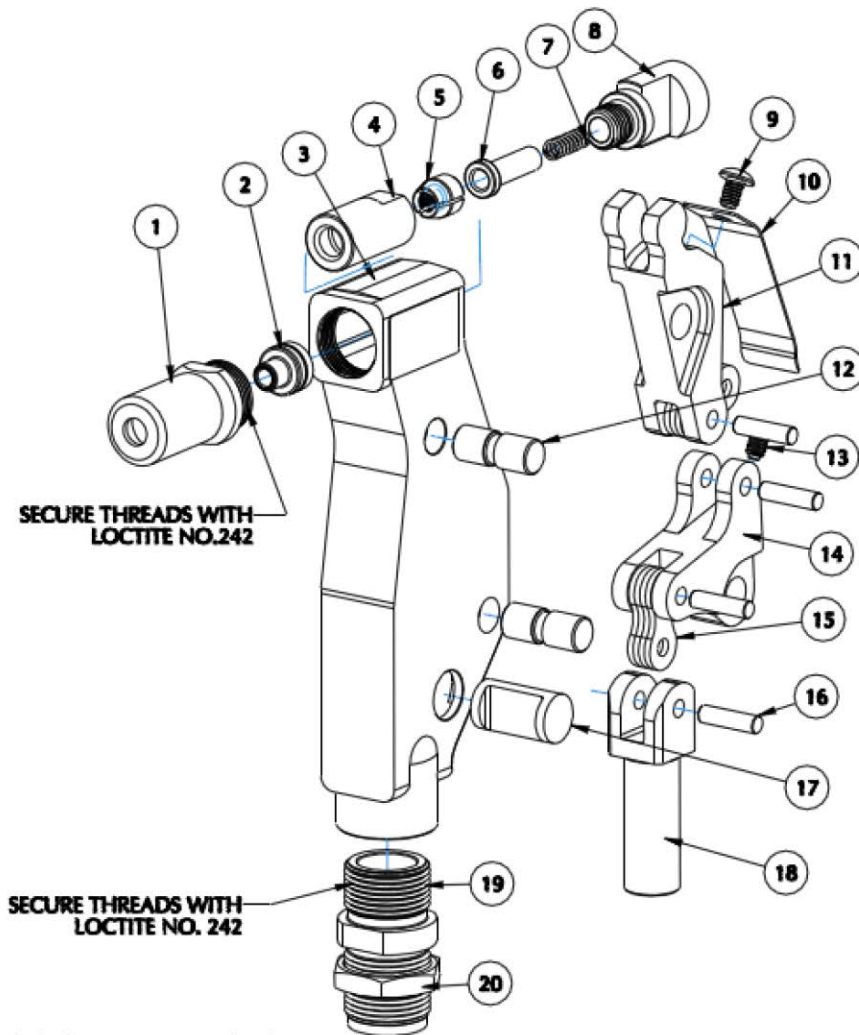

WHEN RE-ASSEMBLING:

- Lubricate outside of pilot insert with O-ring lubricant or equivalent.
- Oil or grease heavily all sliding surfaces with Lubriplate® or equivalent.
- Use Loctite® 242 (removable) on sleeve and collet threads.

GENERAL / TECHNICAL QUESTIONS

1224 E. Warner Avenue
 Santa Ana, CA 92705 USA
 1-714-850-6022 (Phone)
 1-714-850-6093 (Fax)

LOCTITE® is a registered trademark of Henkel Corporation.
 LUBRIPLATE® is a registered trademark of Fiske Brothers Refining Co.

WARRANTY

Seller warrants the goods conform to applicable specifications and drawings and will be manufactured and inspected according to generally accepted practices of companies manufacturing industrial or aerospace fasteners. In the event of any breach of the foregoing warranty, Buyer's sole remedy shall be to return defective goods (after receiving authorization from Seller) for replacement or refund of the purchase price, at the Seller's option. Seller agrees to any freight costs in connection with the return of any defective goods, but any costs relating to removal of the defective or nonconforming goods or installation of replacement goods shall be Buyer's responsibility. SELLER'S WARRANTY DOES NOT APPLY WHEN ANY PHYSICAL OR CHEMICAL CHANGE IN THE FORM OF THE PRODUCT IS MADE BY BUYER. THE FOREGOING EXPRESS WARRANTY AND REMEDY ARE EXCLUSIVE AND ARE IN LIEU OF ALL OTHER WARRANTIES AND REMEDIES; ANY IMPLIED WARRANTY AS TO QUALITY, FITNESS FOR PURPOSE, OR MERCHANTABILITY IS HEREBY SPECIFICALLY DISCLAIMED AND EXCLUDED BY SELLER. This warranty is void if seller is not notified in writing of any rejection of the goods within ninety (90) days after receipt of the goods by buyer.

Seller shall not be liable under any circumstances for incidental, special or consequential damages arising in whole or in part from any breach by Seller, AND SUCH INCIDENTAL, SPECIAL, OR CONSEQUENTIAL DAMAGES ARE HEREBY EXPRESSLY EXCLUDED.

Our policy is one of continuous development. Specifications shown in this document may be subject to changes introduced after publication.

NOTE: The properties, strength, dimensions, installed characteristics and all other information in these materials are for guidance only to aid in the correct selection of the products described herein and is not intended or implied as part of the above warranty. All applications should be evaluated for functional stability and available samples of the described parts can be requested for installed tests, suitability and evaluations.

For more information please contact our Technical Services Department at tel. 714-850-6022

USATCO U.S. Air Tool Company, Inc.

Info@usatco.com

Eastern Division60 Fleetwood Ct., Ronkonkoma, NY 11779-6907 tel: (631) 471-3300 fax: (631) 471-3308

Western Division1219 W. Mahalo Place, Rancho Dominguez, CA 90220-5446 tel: (310) 632-5400 fax: (310) 632-3900