

53-400 Rivet Removal Tool

Parts List & Instructions For Use

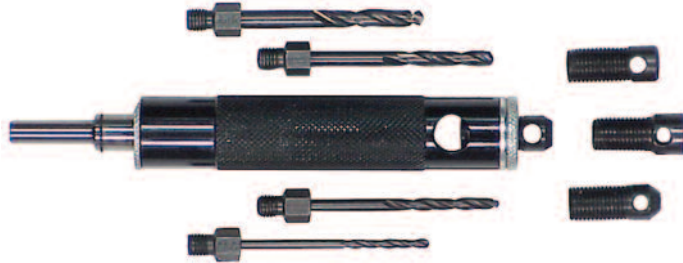

H.S.S. Replacement Bits	
Part Number	Size
02-2972-10	#10
02-2972-21	#21
02-2972-30	#30
02-2972-40	#40
53-2972	Set Of All Four Sizes

Changing & Replacing Bits

1. Back off knurled lock nut.
2. Remove drill guide.
3. Unscrew brass bushing at top of tool.
4. Remove drive shaft, spring & bit.
5. Remove bit from shaft and install desired bit.
6. Apply a drop of light machine oil on the drive shaft at the brass bushing.
7. Install drive shaft & spring in housing and tighten brass bushing.
8. Install knurled nut on corresponding drill guide (#40 bit with #40 drill guide, etc.)
9. Reinstall drill guide in housing.

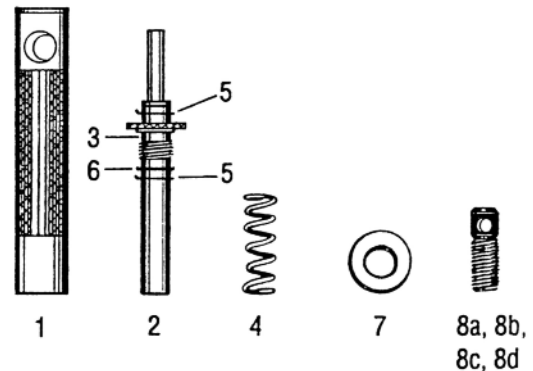

Bit Depth Adjustment

1. Disconnect power tool from air or power supply.
2. Install tool in drill chuck and tighten chuck.
3. Pull housing towards chuck and tight chuck.
4. Adjust guide to desired depth and tighten lock nut.
5. Reconnect tool to air or power supply and proceed.

Usage Recommendations

1. During use, frequently dip the bit in cutting fluid to keep cool & lubricated.
2. When drilling steel rivets or blind rivets with steel shank use a slow drill speed and higher feed pressure.
3. Care should be taken to keep nosepiece clear of metal chips during drilling .
4. Make sure to use properly sharpened bits.

Parts List			
Index	Part Number	Description	Qty.
1	38-4001	Housing	1
2	38-4002	Shaft	1
3	38-4003	Bushing	1
4	38-4004	Spring	1
5	38-4005	Retaining Ring	2
6	38-4006	Washer	1
7	38-4007	Threaded Washer	1
8a	38-4008	Nosepiece (#10)	1
8b	38-4009	Nosepiece (#21)	1
8c	38-4010	Nosepiece (#30)	1
8d	38-4011	Nosepiece (#40)	1

To reorder use part numbers listed above.

Toll Free Nationwide & Canada: **800-645-8180**

USATCO\U.S. AIR TOOL COMPANY, INC. WWW.USATCO.COM NEW YORK • CALIFORNIA

Rev0418