

# G744



**CHERRY**<sup>®</sup>  
AEROSPACE

CherryMAX<sup>®</sup> Power Riveter  
NSN 5130-01-151-1856



Instruction Manual **CE**

Pass on to user to read and keep for reference

# MANUAL



# THE G744 TOOL

## TABLE OF CONTENTS

Description .....	1
Specifications for G744 .....	1
Safety Warnings .....	2
How to Use the G744 .....	3
Maintenance and Repair .....	3
Fill and Bleed Instructions .....	4
Trouble Shooting .....	4
Overhaul .....	5
Air Valve .....	5
Head Sub-Assembly .....	5
Handle Sub-Assembly .....	6
G744 Pulling Heads .....	6
Installing Pulling Heads .....	7
Cross Section Drawing of G744 .....	8
Parts List for G744 Riveter .....	9
Exploded View of G744 .....	10
Declaration of Conformity .....	Back Cover

## DESCRIPTION

The Cherry G744 is a pneumatic-hydraulic tool designed specifically for the most efficient installation of 1/4" CherryMAX® rivets. However, with the proper pulling heads and adapter, this tool can install other sizes and types of rivets. This tool utilizes straight, offset and right-angle pulling heads. Extensions are available for extending the pulling heads to reach limited access areas. Refer to the pulling head section for the correct pulling head part number for the rivet to be installed.

Its all metal housing makes this tool extremely durable for use in a shop environment. It can be operated in any position with one hand. A stem catcher bag may be ordered separately and attached to eliminate costly clean-up.

## SPECIFICATIONS FOR G744

Cherry Aerospace' (CHERRY) policy is one of continuous development. Specifications shown in this document may be subject to change which may be introduced after publication. For the latest information always consult CHERRY.

AIR PRESSURE	90 to 110 PSI (6.2 to 7.6 bar)
STROKE	0.625 inch (15.88 mm)
PULLING FORCE	3800 Pounds (16.90 kN) @ 90 PSI (6.2 bar)
CYCLE TIME	Approximately one second
WEIGHT	7 Pounds (3.18 kg)
NOISE LEVEL	72 dB (A)
VIBRATION	Less than 2.5 m/s <sup>2</sup>
AIR CONSUMPTION	0.31 SCF/cycle (8.78 L/cycle)

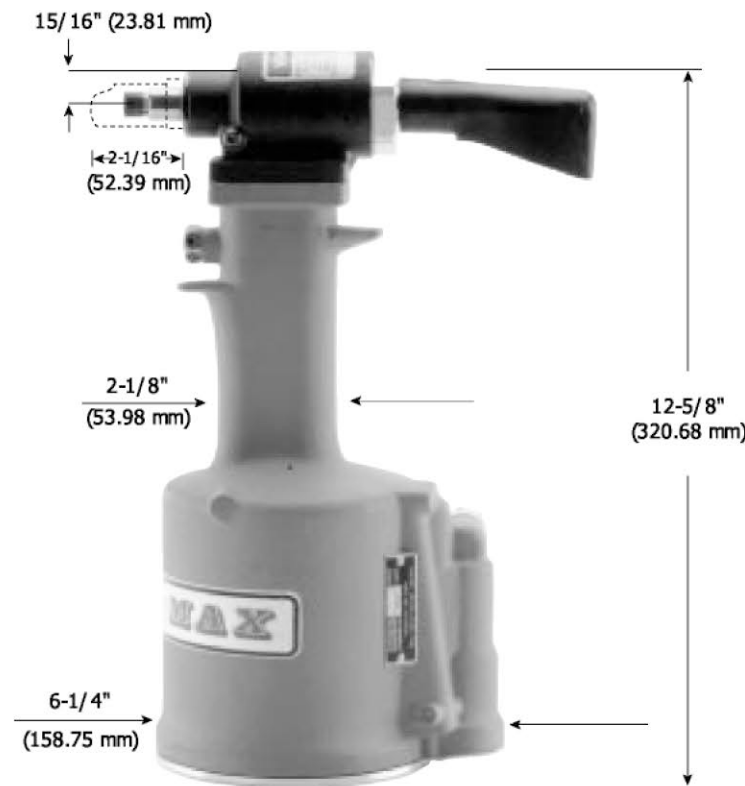

## **SAFETY WARNINGS**

- **Operating this tool with a damaged or missing stem deflector, or using the deflector as a handle, may result in severe personal injury. The pin deflector should be rotated until the aperture is facing away from the operator and other persons working in the vicinity.**
- **Approved eye protection should be worn when operating, repairing, or overhauling this tool.**
- **Do not use beyond the design intent.**
- **Do not use substitute components for repair.**
- **Any modification to the tool, pulling heads, accessories or any component supplied by CHERRY®, or their representatives, shall be the customer's entire responsibility. CHERRY® will be pleased to advise on any proposed modification.**
- **The tool must be maintained in a safe working condition at all times and examined at regular intervals for damage.**
- **Before disassembling the tool for repair, refer to the maintenance instructions. All repairs shall be undertaken only by personnel trained in CHERRY® installation tools. Contact CHERRY® with your training requirement.**
- **Always disconnect the air line from the tool inlet before attempting to service, adjust, fit or remove any accessory.**
- **Do not operate the tool when it is directed at any person.**
- **Ensure that the vent holes do not become blocked or covered and that air line hoses are always in good condition.**
- **Avoid excessive contact with the hydraulic fluid to minimize the possibility of skin rashes. Care should be taken to wash thoroughly.**
- **Operating air pressure should not exceed 110 psi (7.6 bar).**
- **Do not operate the tool without the pulling head in place.**
- **Do not operate the tool unless the handle base (25) is fully secured by the retaining ring (26).**
- **All retaining rings, screwed end caps, air fittings, trigger valves and pulling heads should be attached securely and examined at the end of each working shift.**
- **Do not pull rivet in the air.**
- **The precautions to be used when using this tool must be explained by the customer to all operators. Any questions regarding the correct operation of the tool and operator safety should be directed to CHERRY®.**
- **Do not pound on the rear of the tool head to force rivets into holes as this will damage the tool.**
- **Do not depress the trigger while disconnecting the air bleeder and replacing the cap screw when bleeding the tool.**

# HOW TO USE THE G744

After selecting the proper pulling head and attaching it securely to the G744, connect the air line to the tool. Insert the rivet stem into the pulling head until the head of the rivet is in contact with the pulling head sleeve. This will ensure full engagement between the jaws and the rivet stem and will prevent slippage.

Once the rivet stem is inserted in the H744A-8 pulling head, the rivet must be installed. The "stem stop" in the pulling head will prevent the mandrel from moving back out the front of the head.

Insert the rivet into the application and pull the trigger to activate the tool. Upon the release of the trigger, the stem will eject to the rear of the tool (when using the H744A-8 straight pulling head). When using the H827-8 offset pulling head, the stem will eject through offset pulling head to the rear. When using the H828-8 right angle pulling head, the stem will eject out the front.

## MAINTENANCE AND REPAIR

The G744 Power Riveter has been manufactured to give maximum service with minimum care. In order that this may be accomplished, the following recommendations should be followed:

1. The hydraulic system should be full of fluid and free from air at all times.
2. Keep excessive moisture and dirt out of air supply to prevent wear of air valve, air cylinder and air piston.
3. Tool should be routinely inspected for fluid leaks.
4. Do not pound the rear of the tool head to force rivets into holes as this will damage the tool.
5. Make sure the pulling head is correctly and securely attached.

Use automatic transmission fluid Type "A" (no substitutes). Cherry Aerospace recommends using ATF, Dexron III fluid.

## DEXRON III FLUID SAFETY DATA

### FIRST AID

*Skin:* Wash thoroughly with soap and water as soon as possible. Casual contact requires no immediate attention. If irritation develops, consult a physician.

*Ingestion:* Seek medical attention immediately. DO NOT INDUCE VOMITING.

*Eyes:* Flush with copious amounts of water. If irritation develops, consult a physician.

*Inhalation:* No significant adverse health effects are expected to occur on short term exposure. Remove from contaminated area. Apply artificial respiration if needed. If unconscious, consult physician.

### FIRE

*Suitable extinguishing media:* CO<sub>2</sub>, dry powder, foam or water fog. DO NOT use water jets.

### ENVIRONMENT

*Waste Disposal:* In accordance with local, state and federal regulations.

*Spillage:* Prevent entry into drains, sewers and water courses. Soak up with diatomaceous earth or other inert material. Store in appropriate container for disposal.

### HANDLING

Eye protection required. Protective gloves recommended. Chemically resistant boots and apron recommended. Use in well ventilated area.

### COMBUSTIBILITY

Slightly combustible when heated above flash point. Will release flammable vapor which can burn in open or be explosive in confined spaces if exposed to source of ignition.

### STORAGE

Avoid storage near open flame or other sources of ignition.

### PROPERTIES

<i>Specific gravity</i>	0.863
<i>Weight per gallon</i>	7.18 lbs.
<i>Open flash point</i>	>200°C (392°F)

## FILL AND BLEED INSTRUCTIONS

Bleeding replaces a small amount of fluid in the tool and eliminates any air from the system : connect the tool to the air line, remove cap screw (14). (CAUTION: Do not depress trigger without cap screw or air bleeder attached.) Attach the Cherry air bleeder (700A77), and slowly cycle tool several times. This will ensure the removal of any air from the hydraulic system and its replacement with fluid.

Should it become necessary to completely refill the tool (such as would be required after the tool has been dismantled and re-assembled), take the following steps:

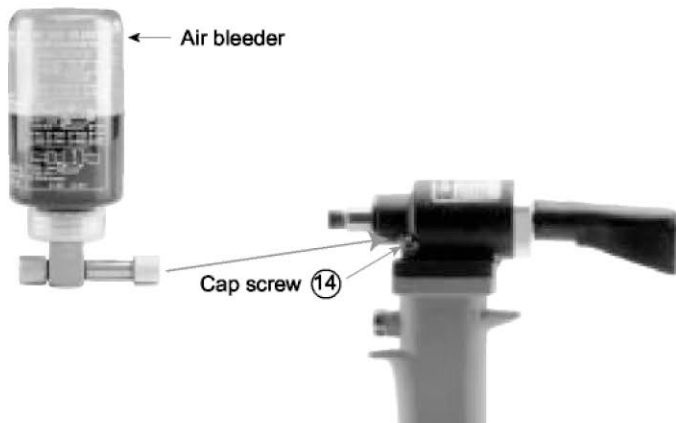

After removing head assembly, fill handle assembly (31) with the recommended fluid to within 1/8" (3 mm) of the top of the handle casting.

Replace head assembly (1) on the handle (31), being sure gasket (53) and O-ring (52) are properly in place. Tighten cap screws (54) uniformly to prevent leakage around gasket.

Remove the cap screw (14), attach Cherry Air Bleeder (700A77). Bleeder (700A77) should not be filled past safety line on bottle.

Connect tool to air line, purge system of air by cycling ten times slowly or until bottle is free of air bubbles to fully circulate fluid through the hydraulic system

DO NOT depress trigger while disconnecting the Air Bleeder and replacing the cap screw (14).

## TROUBLESHOOTING

1. Check the airline for correct pressure at the tool. It must be 90 to 110 PSI (6.2 to 7.6 bar).

2. Check for fluid leakage:

- Fluid leaking around the cap screw (14) in the head indicates that the screw is loose or the Stat-O-Seal (13) needs replacing.
- If fluid should leak through the by-pass hole at the base of the handle (31) the O-ring (34) is worn or damaged.
- Fluid leaking from the front of the head (1) indicates that O-rings (2) are worn or damaged. Replace.

3. Check for excessive air leakage from the air valve:

- If spring (40) is broken or dislodged, air will bleed directly through the bottom of the air valve and the head piston retreats to its full stroke without returning. See air valve instructions on Page 5.
- If O-ring (45) on plug (46) is worn or damaged, replace.
- If O-rings (41) on valve spool (42) are worn or damaged, replace.

4. Check movement of the head piston (4). If it does not move freely or is slow in operation:

- O-rings (2), (5), (7) and (8) may be damaged and require replacement.
- Piston (4) may be mechanically locked due to damaged parts.
- Muffler (47) or air filter (43) inside valve spool (42) may be plugged with dirt. Clean them thoroughly with normal solvent and back-blow with compressed air.
- Hole in metering screw (44) in valve spool (42) may be blocked or damaged. Hole diameter should be .028" (.71 mm). Clear and size or replace valve spool assembly (56). Metering screw (44) and filter (43) are not sold separately.

5. Rivet stem sticks in the pulling head:

- Pulling head components need maintenance. Disassemble the pulling head, clean and replace worn parts. Reassemble following instructions on page 7.
- Spent rivet stems are wedged side by side in the pulling head. Disassemble the pulling head, remove stems and reassemble following the instructions on page 7.

USATCO U.S. Air Tool Company, Inc.

Eastern Division .....60 Fleetwood Ct., Ronkonkoma, NY 11779-6907 tel: (631) 471-3300 fax: (631) 471-3308  
Western Division .....1219 W. Mahalo Place, Rancho Dominguez, CA 90220-5446 tel: (310) 632-5400 fax: (310) 632-3900

Info@usatco.com

## OVERHAUL

**CAUTION:** Always disconnect the air supply before any overhaul or maintenance.

The disassembly and reassembly procedures can be accomplished by following the instructions below and the drawings on pages 8 & 10.

**Use extreme care during disassembly and reassembly not to mar, nick or burr any smooth surface that comes in contact with sealing elements.** Before installing O-rings, be sure to apply an O-ring lubricant, such as Lubriplate® 630-A.

It is recommended that special assembly tools, which can be ordered under part number G740KT, be used to overhaul this tool.

For a complete overhaul, order Service Kit G744KS which contains a complete set of O-rings, back-up rings, screws, washers and gaskets.

## THE G740KT TOOL KIT



836B740  
Valve Spring Installation Tool



837B740  
Valve Sleeve Removal Tool



740A43  
Power Cylinder Tool



700A61  
Piston Rod Wrench

### Not shown, but included: 740A42 Seal Guide

Virtually all of the moving parts in this tool ride on O-rings, protected by back-up rings where high pressure dictates. This means no metal to metal wear. By use of close tolerances and low micro-inch surfaces against which the O-rings seal, a long life can be expected before any overhaul becomes necessary.



700B65  
Packing Plug Wrench



P1178  
Valve Plug Extractor



740A42  
Seal Guide



700A77  
Air Bleeder

## AIR VALVE

- Disconnect tool from air supply. Remove retaining ring (48) and muffler (47). Insert a valve plug extractor (P1178), or a 5/16-18 threaded rod or bolt, into end of valve plug (46) and pull it out. Using the same procedure, pull out spool assembly (56).

**NOTE:** It should never be necessary to remove valve sleeve (39) unless the ports in the sleeve are plugged up tightly from contaminated air. O-rings on this sleeve are static and hence do not wear. If it is suspected that the ports are plugged, use the following procedure:

- Use needle nose pliers to grasp the end of the spring (40), turn clockwise and pull out to dislodge from groove in handle.
- With spring removed, valve sleeve (39) can be pulled out using the valve sleeve removal tool (837B740).

To re-assemble, reverse the above procedures being certain that all O-rings are properly lubricated. To avoid damaging the O-rings (38), carefully install sleeve (39) with your finger. Gently push and wiggle sleeve to allow O-rings to slip past inner ports.

Spring (40) is best installed using a valve spring installation tool (836B740) to push the large diameter coil into the groove.

This requires care as the tool will not operate if the spring is not anchored firmly.

## HEAD SUB-ASSEMBLY

- Disconnect air supply and remove the complete pulling head from the tool before attempting to disassemble the head assembly.
- Remove the four socket head cap screws (54). Lift head assembly from the handle (31). Remove O-ring (52) and gasket (53). Empty the fluid into a container by pouring from the handle. Dispose of the fluid according to environmental regulations.
- Remove end cap (9). Push against threaded end of head piston (4) and slide it out of head body (1). Be careful not to damage threads or cause burrs on polished head piston rod surface.
- O-rings (2) and back-up ring (3) can now be removed using a bent hook. O-ring (8) can be removed in the same manner.
- Upon re-assembly, be sure to install O-rings and back-up rings carefully to avoid cutting them. Always lubricate all O-rings. Just prior to placing the head sub-assembly onto the handle, see Fill and Bleed Instructions. Also make sure to place O-ring (52) and the gasket (53) on the top of the handle, and that they are properly oriented.
- Tighten the four socket-head cap screws (54) uniformly to prevent leakage around the gasket.
- Purge system of air using Cherry air bleeder (700A77) according to the "Fill and Bleed Instructions".

## HANDLE SUB-ASSEMBLY

- Disconnect tool from air supply. Remove parts (24) through (28).
- Holding tool upright, remove four socket-head cap screws (54). Lift head assembly from handle (31) and set aside O-ring (52) and gasket (53). Empty all fluid into a container by pouring from handle.
- Place piston rod wrench (700A61) down into the top of the handle (31), into the hex socket in the head of the power piston rod (37). While holding this wrench remove the locknut (23) using the 7/16" socket in packing plug wrench (700B65).
- Still holding the piston wrench, remove the air piston (22) using the packing plug wrench (700B65) by turning counterclockwise. When air piston is completely freed from the piston rod, tap or push on the piston rod wrench to eject the piston from bottom of handle.
- Slide power piston rod (37) back up to the end of its travel. Using the packing plug wrench (700B65), remove packing plug (18). It may be necessary to hold the handle upside down in a vise while removing the packing plug.
- Power cylinder (32) can be tapped out by lowering power cylinder tool (740A43) down into the top of the handle onto top of cylinder. The O-rings (15) and back-up rings (16) are best removed and replaced by using a thin bent hook.

To re-assemble the handle, reverse the above procedure, being certain that all the O-rings are properly lubricated before installation. Attach the seal guide (740A60) to the piston rod (37) and with a mallet, tap the piston rod through the packing plug (18). When re-assembling a replacement air piston, items (19) through (23), follow the instructions given below:

- Clamp piston rod wrench (700A61) in a vise with the hex shaft pointed up.
- Turn the handle upside down and place the hex end of the piston rod (37) onto the wrench (700A61). Push handle casting down until it stops.
- Assemble seal (20) and back-up rings (19) to air piston (22).
- Place the air piston (22) into the handle bore. Be sure that the smooth side of the air piston (22) is facing towards you.
- Thread the locknut (23) onto the piston rod and tighten between 50 in.-lb (5.65 N-m) and 59 in.-lb (6.67 N-m) of torque.

## G744 PULLING HEADS

Pulling Heads are not furnished with riveter and must be ordered separately.

See the appropriate Tool Sheet for mounting, maintenance and operation instructions of particular pulling heads.

Pulling Head	Type	Adapter	Rivet	Rivet Diameters	Maximum Grip
H744A-8	Straight	-	Bulbed CherryMAX® Wiredraw CherryMAX®	1/4 1/4	All -4 <sup>1</sup>
H828-8	Right Angle	-	Bulbed CherryMAX® Wiredraw CherryMAX®	1/4 1/4	All -4 <sup>1</sup>
H827-8	Offset	-	Bulbed CherryMAX® Wiredraw CherryMAX®	1/4 1/4	All -4 <sup>1</sup>
H846-456	Straight	-	Bulbed CherryMAX® Wiredraw CherryMAX®	1/8, 5/32, 3/16 <sup>2,3</sup> 1/8, 5/32, 3/16 <sup>3</sup>	All -4 <sup>1</sup>
H701B-456	Straight	744A20	Bulbed CherryMAX® Wiredraw CherryMAX®	1/8, 5/32, 3/16 <sup>2,3</sup> 1/8, 5/32, 3/16 <sup>3</sup>	All -6 <sup>1</sup>
H753A-456	Right Angle	744A20	Bulbed CherryMAX® Wiredraw CherryMAX®	1/8, 5/32, 3/16 <sup>2,3</sup> 1/8, 5/32, 3/16 <sup>3</sup>	All -4 <sup>1</sup>
H781-456	Offset	744A20	Bulbed CherryMAX® Wiredraw CherryMAX®	1/8, 5/32, 3/16 <sup>2,3</sup> 1/8, 5/32, 3/16 <sup>3</sup>	All -4 <sup>1</sup>
H782-( )	Offset	744A20	Various Fasteners (see Tool Sheet)	Various sizes (see Tool Sheet)	
H744-5MB H744-6MB	Straight	-	"S" Type Maxibolt®	5/32, 3/16	All
H828-5MB H828-6MB	Right Angle	-	"S" Type Maxibolt®	5/32 3/16	All
H828-56MBP	Right Angle	-	Maxibolt® Plus	5/32 3/16	All
H856-6MB	Offset	-	"S" Type Maxibolt®	3/16	All

1. On the first stroke.

2. Nominal and oversize.

3. No 3/16 aluminum, Alloy steel and Monel only.



# CROSS SECTION OF G744

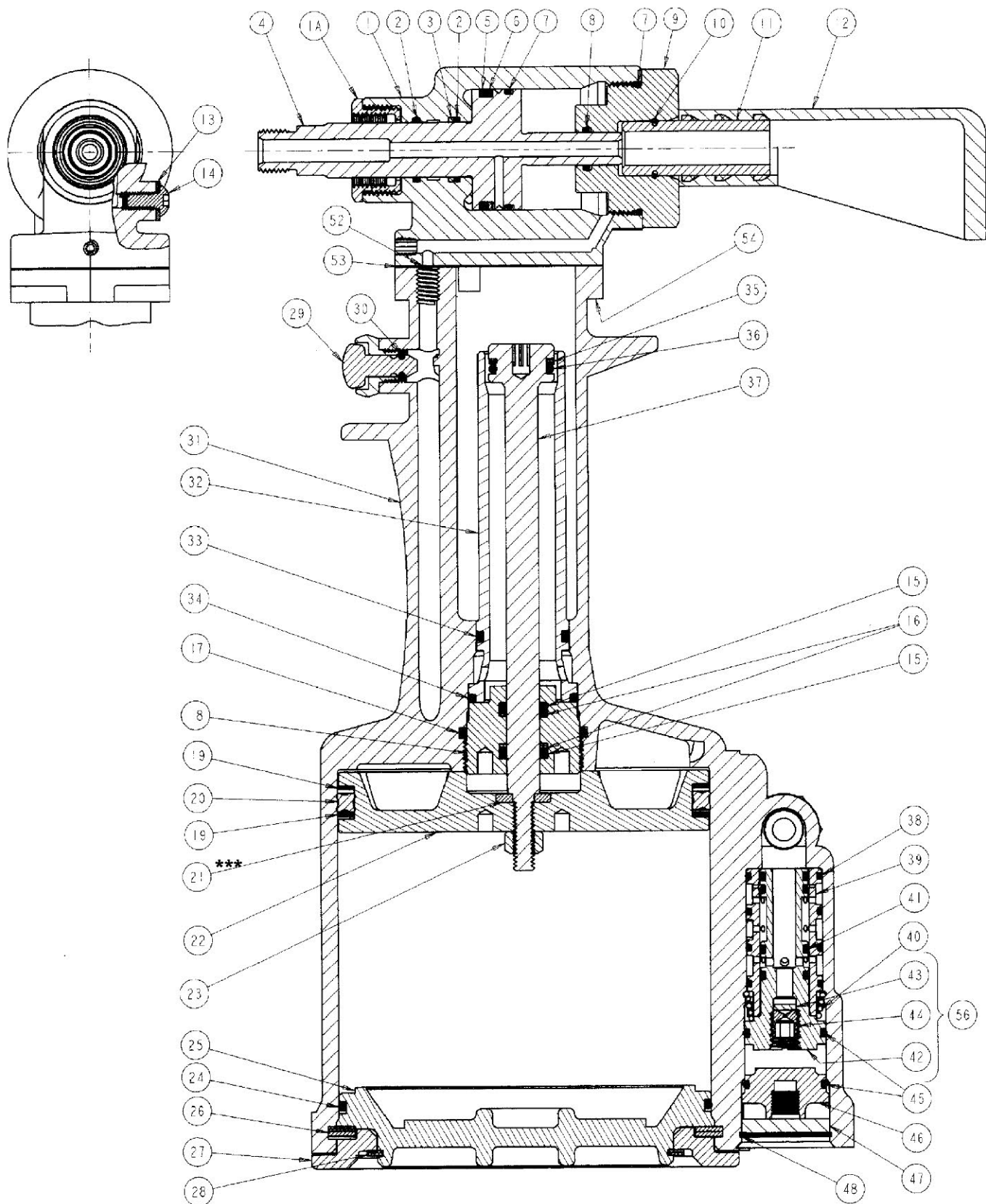

# PART LIST FOR THE G744 (744-081) RIVETER ASSEMBLY

ITEM	PART NO	DESCRIPTION	QTY	
744B5 SUB-ASSEMBLY, HEAD				
744B6 SUB-ASSEMBLY, HEAD CYLINDER				
1	744D2	CYLINDER, HEAD	1	
1A	744B7	FITTING, NOSE	1	
2	P-621	O-RING	2	
3	P-1119	RING, BACK-UP	1	
4	744C3	PISTON, HEAD	1	
5	P-877	O-RING	1	
6	P-878	RING, BACK-UP	1	
7	P-553	O-RING	2	
8	P-112	O-RING	1	
9	744B4	CAP, HEAD	1	
10	P-880	RING, RETAINING (NON-STANDARD)	1	
11	703A13	FITTING, DEFLECTOR	1	
12	530A16	DEFLECTOR, PIN	1	
13	P-572	STAT-O-SEAL	1	
14	P-881	SCREW, BUTTON HD. SOC. (10-32 x 3/8)	1	
744-C34 SUB-ASSEMBLY, HANDLE				
15	P-838**	O-RING, DISOGRIN	2	
16	P-115	RING, BACK-UP	2	
17	P-889	O-RING	1	
18	740B13	PLUG, PACKING	1	
19	P-909	RING, BACK-UP	2	
20	P-887	RING, QUAD	1	
21	700A21	WASHER (REF.)***	1	
22	740B6	PISTON, AIR (INCLUDES 700A21)	1	
23	P-737	NUT, CONELOK 1/4-20	1	
24	P-890	O-RING	1	
25	740C4	BASE, HANDLE	1	
26	P-886	RING, RETAINING	1	
27	740B5	COVER, BASE	1	
28	P-884	RING, RETAINING	1	
29	703A33	ASSEMBLY, TRIGGER (INCLUDES P-223)	1	
30	P-223	O-RING	1	
31	743A11	HANDLE	1	
32	740C7	CYLINDER, POWER	1	
33	P-833**	O-RING, DISOGRIN	1	
34	P-892**	O-RING, DISOGRIN	1	
35	P-908	RING, BACK-UP	1	
36	P-508	O-RING	1	
37	740A8	ROD, POWER PISTON	1	
38	P-268	O-RING	4	
39	740B46	SLEEVE, VALVE	1	
40	740A18	SPRING	1	
41	P-891	O-RING	4	
56	740A44 SUB-ASSEMBLY, VALVE SPOOL		1	
	42	740B45***	SPOOL, VALVE	1
	43	700A18***	FILTER	1
	44	700A69***	SCREW, METERING	1
45	P-848	O-RING	2	
46	740B16	PLUG, VALVE	1	
47	740A17	MUFFLER	1	
48	P-321	RING, RETAINING (INT. Ø1.000)	1	
49	530A34	SWIVEL	1	
50	P-195	O-RING (.630, .424, .103)	2	
51	530A35	BOLT, SWIVEL	1	
52	P-832**	O-RING, DISOGRIN	1	
53	700A22	GASKET	1	
54	P-91	SCREW, SOC HD. CAP, 10-24 X 1/2	4	
55	670A20*	BAG, STEM CATCHER	1	

\*Not furnished with riveter; must be ordered separately if desired.

\*\*No substitutions.

\*\*\* Not sold separately.

Note: Use Loctite® #271 or equivalent when assembling items 1 and 1A.

# EXPLODED VIEW OF G744

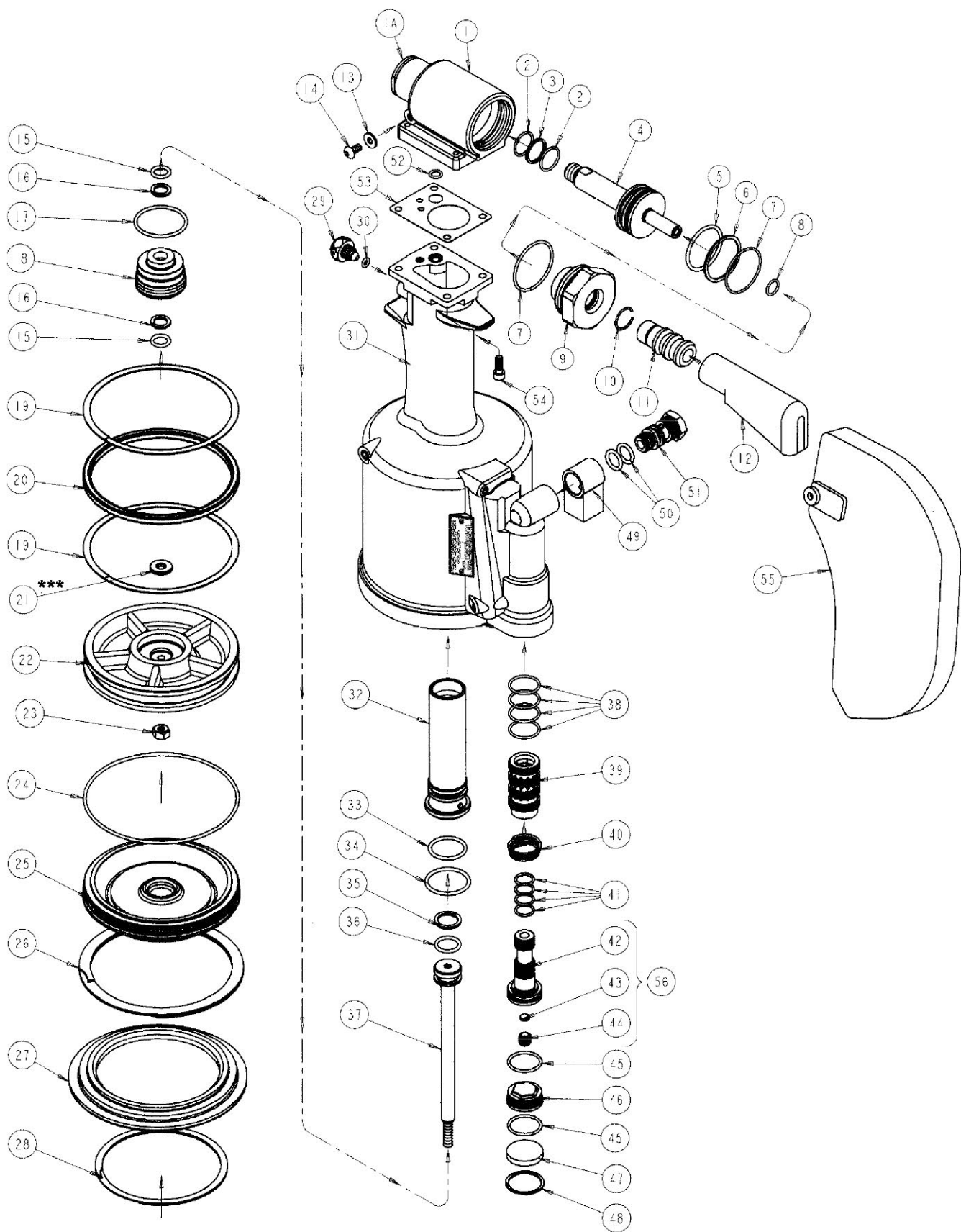

# Declaration of Conformity

We, Cherry® Aerospace, 1224 E. Warner Ave., Santa Ana, CA 92705

declare under our sole responsibility that the product

type **G744**

Serial No.-

to which this declaration relates is in conformity with the following standards

EN292 part 1 and part 2  
ISO 8662 Part 1  
ISO 3744

following the provisions of the Machine Directive 89/392/EEC  
(as amended by Directive 91/368/EEC) and 93/68/EEC

Santa Ana, CA -  
date of issue

Original certification and signatures on file

## WARRANTY

Seller warrants the goods conform to applicable specifications and drawings and will be manufactured and inspected according to generally accepted practices of companies manufacturing industrial or aerospace fasteners. In the event of any breach of the foregoing warranty, Buyer's sole remedy shall be to return defective goods (after receiving authorization from Seller) for replacement or refund of the purchase price, at the Seller's option. Seller agrees to any freight costs in connection with the return of any defective goods, but any costs relating to removal of the defective or nonconforming goods or installation of replacement goods shall be Buyer's responsibility. SELLER'S WARRANTY DOES NOT APPLY WHEN ANY PHYSICAL OR CHEMICAL CHANGE IN THE FORM OF THE PRODUCT IS MADE BY BUYER.

THE FOREGOING EXPRESS WARRANTY AND REMEDY ARE EXCLUSIVE AND ARE IN LIEU OF ALL OTHER WARRANTIES AND REMEDIES; ANY IMPLIED WARRANTY AS TO QUALITY, FITNESS FOR PURPOSE, OR MERCHANTABILITY IS HEREBY SPECIFICALLY DISCLAIMED AND EXCLUDED BY SELLER. THIS WARRANTY IS VOID IF SELLER IS NOT NOTIFIED IN WRITING OF ANY REJECTION OF THE GOODS WITHIN ONE (1) YEAR AFTER INITIAL USE BY BUYER OF ANY POWER RIVETER OR NINETY (90) DAYS AFTER INITIAL USE OF ANY OTHER PRODUCT.

Seller shall not be liable under any circumstances for incidental, special or consequential damages arising in whole or in part from any breach by Seller. AND SUCH INCIDENTAL, SPECIAL, OR CONSEQUENTIAL DAMAGES ARE HEREBY EXPRESSLY EXCLUDED.

For more information please contact our Technical Services Department at Tel. 714-850-6022

*LOCTITE® is a registered trademark of Henkel Corporation  
DEXRON® is a registered trademark of GM corporation.  
PARKER® is a trademark of Parker Hannifin Corporation  
LUBRRPLATE® is a trademark of Fiske Brothers Refining Co.*



**USATCO U.S. Air Tool Company, Inc.**

**Info@usatco.com**

**Eastern Division** .....60 Fleetwood Ct., Ronkonkoma, NY 11779-6907 tel: (631) 471-3300 fax: (631) 471-3308

**Western Division** .....1219 W. Mahalo Place, Rancho Dominguez, CA 90220-5446 tel: (310) 632-5400 fax: (310) 632-3900