

HLS79 SERIES  
2" EXTENDED SOCKET  
(USE TABLE 1)

HLS80 SERIES  
4" EXTENDED SOCKET  
(USE TABLE 2)

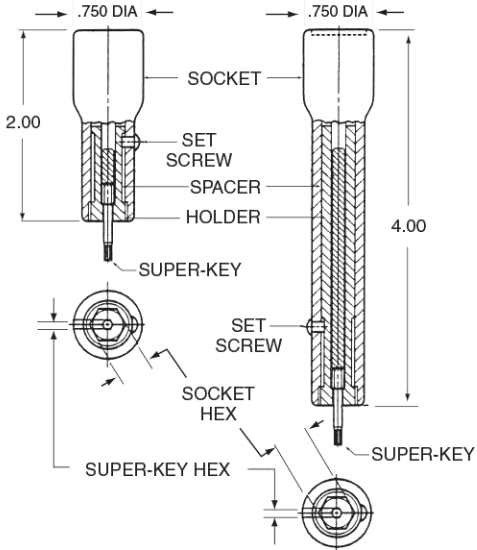

# INSTALLATION TOOLING SUPER HLA1051

**Straight Driver Assembly  
with Extended Socket  
and Super-Key™ (T-Series)**

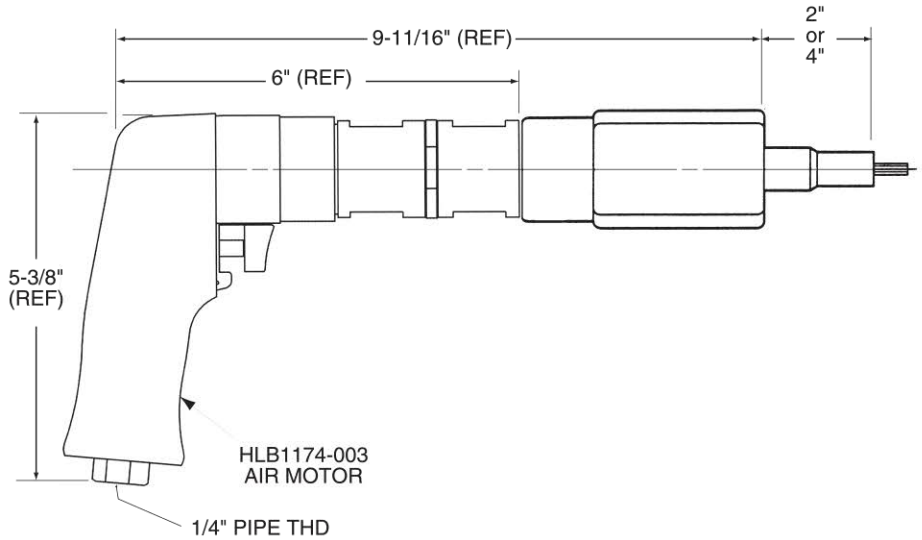

DRIVER BASIC PART NO.  
**HLA1051-312(X)-078-T**

SOCKET HEX REF. TABLE 1 OR 2

SOCKET LENGTH: X = 4.0", NO LETTER = 2.0"

SUPER-KEY HEX REF. TABLE 1 OR 2.

SUPER-KEY (T-SERIES)

Example: complete driver assy. part no.

### ORDERING INFORMATION

1. Match pin and collar hexes with Super-Key Hex and Socket Hex.
2. See tables 1 & 2 for corresponding complete driver assy part no.

### TECHNICAL DATA

Operating Pressure .....	90 PSIA	Horsepower Rating .....	0.70
<b>MAX. TORQUE RATING</b> .....	300 in. lb (Motor) @ 90 PSIA	Air Consumption .....	22 scfM
Socket Speed .....	250 RPM	Weight .....	3.8 lb

**TABLE 1**

**TABLE 2**

COLLAR DRIVING HEX (Matches Socket Hex)	PIN RECESS HEX (Matches Super-Key Hex)	COMPLETE DRIVER ASSY. PART NO. w/ HLS79 Series 2" Extended Socket	COLLAR DRIVING HEX (Matches Socket Hex)	PIN RECESS HEX (Matches Super-Key Hex)	COMPLETE DRIVER ASSY. PART NO. w/ HLS80 Series 4" Extended Socket
7/32	1/16	HLA1051-218-062T	7/32	1/16	HLA1051-218X-062T
1/4		HLA1051-250-062T	1/4		HLA1051-250X-062T
9/32		HLA1051-281-062T	9/32		HLA1051-281X-062T
5/16		HLA1051-312-062T	5/16		HLA1051-312X-062T
11/32	5/64	HLA1051-343-062T	11/32	5/64	HLA1051-343X-062T
7/32		HLA1051-218-078T	7/32		HLA1051-218X-078T
1/4		HLA1051-250-078T	1/4		HLA1051-250X-078T
9/32		HLA1051-281-078T	9/32		HLA1051-281X-078T
5/16		HLA1051-312-078T	5/16		HLA1051-312X-078T
11/32		HLA1051-343-078T	11/32		HLA1051-343X-078T
3/8		HLA1051-375-078T	3/8		HLA1051-375X-078T
5/16		3/32	HLA1051-312-094T		5/16
11/32	HLA1051-343-094T		11/32	HLA1051-343X-094T	
3/8	HLA1051-375-094T		3/8	HLA1051-375X-094T	
7/16	HLA1051-437-094T		7/16	HLA1051-437X-094T	

USATCO U.S. Air Tool Company, Inc.

Info@usatco.com

Eastern Division .....60 Fleetwood Ct., Ronkonkoma, NY 11779-6907 tel: (631) 471-3300 fax: (631) 471-3308

Western Division .....1219 W. Mahalo Place, Rancho Dominguez, CA 90220-5446 tel: (310) 632-5400 fax: (310) 632-3900

# HLG101

## Gear Housing Assembly

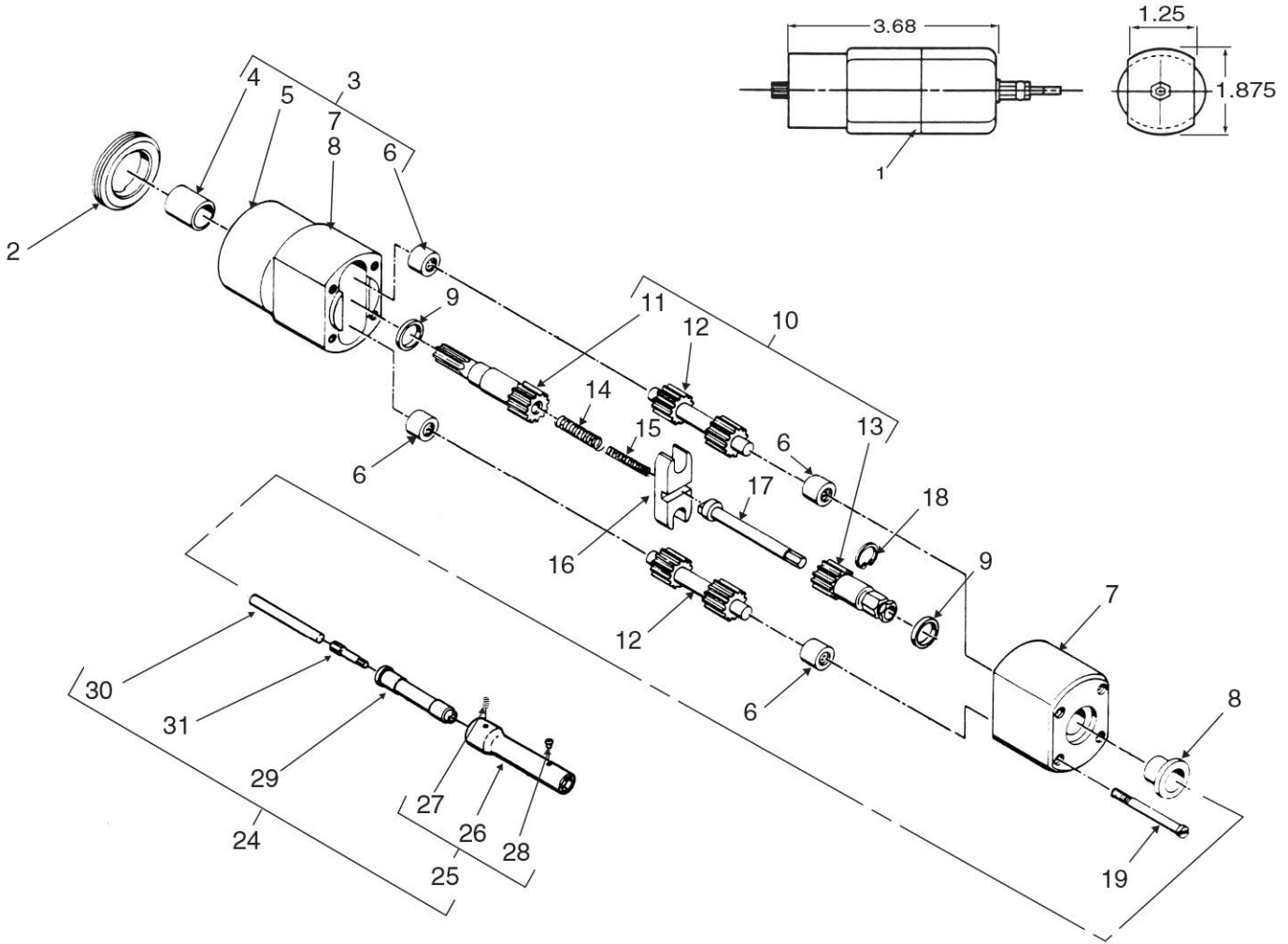

ITEM	PART NO	DESCRIPTION	QTY	ITEM	PART NO	DESCRIPTION	QTY
1	HLG101	Gear housing assy	1	19	AN500-6-24	. Screw	4
2	HLB112	. Nut, jam	1	24	HLS79-(-)(-T	.. Socket assy. (2 in)	1
2a	8-32 x 3/16	. Set screw (use on parts prior to 1-01-2002)	2	24	HLS80-(-)(-T	.. Socket assy. (4 in)	1
3	HLB184	. Housing assy.	1	25	HLS23-(-)	... Socket sub-assy (2 in)	1
4	Boston B68-5	.. Bearing (press fit)	1	25	HLS24-(-)	... Socket sub-assy (4 in)	1
5	HLB184-5	.. Housing, rear	1	26	965050-(-)	.... Socket (2 in)	1
6	B45	.. Bearing (Torrington)	4	26	965052-(-)	.... Socket (4 in)	1
7	HLB184-3	.. Housing, front	1	27	8-32 x 3/16	..... Set screw, Nylok	1
8	HLB185	.. Bearing (press fit)	1	28	6-32 x 5/32	.... Screw, btn hd cap	1
9	HLB181	. Washer, thrust	2	29	HLB1653-(-)	... Holder (2 in)	1
10	HLB63	. Spur gear assy	1	29	HLB1638-(-)	... Holder (4 in)	1
11	HLB464	.. Gear, rear spur	1	30	HLB1616H	... Spacer (2 in)	1
12	HLB465	.. Gear, center spur	2	30	HLB1616J	... Spacer (4 in)	1
13	HLB466	.. Gear, socket drive	1	31	HLT140K-(-)	... Super-Key	1
14	HLB182	. Spring	1				
15	HLB183	. Spring	1				
16	HLB178	. Guide plate	1				
17	HLB180	. Extension	1				
18	HLB186	. Retaining ring	1				

USATCO U.S. Air Tool Company, Inc.

Info@usatco.com

Eastern Division .....60 Fleetwood Ct., Ronkonkoma, NY 11779-6907 tel: (631) 471-3300 fax: (631) 471-3308

Western Division .....1219 W. Mahalo Place, Rancho Dominguez, CA 90220-5446 tel: (310) 632-5400 fax: (310) 632-3900