



04-256-F 37° Double & Single Lap Tube Flaring Tool

*Manufactured
in the USA
by USATCO!*



04-256-F Includes
Double Lap Flaring Tool, Four
Setting Gauges & Fitted Case

**Also Available: Flaring
Tool Kit (shown above)**
53-256-FK Includes
Double Lap Flaring Tool, Four
Setting Gauges, Tubing Cutter
(02-512), Inner-Outer Reamer
(02-208-FSS) & Fitted Case

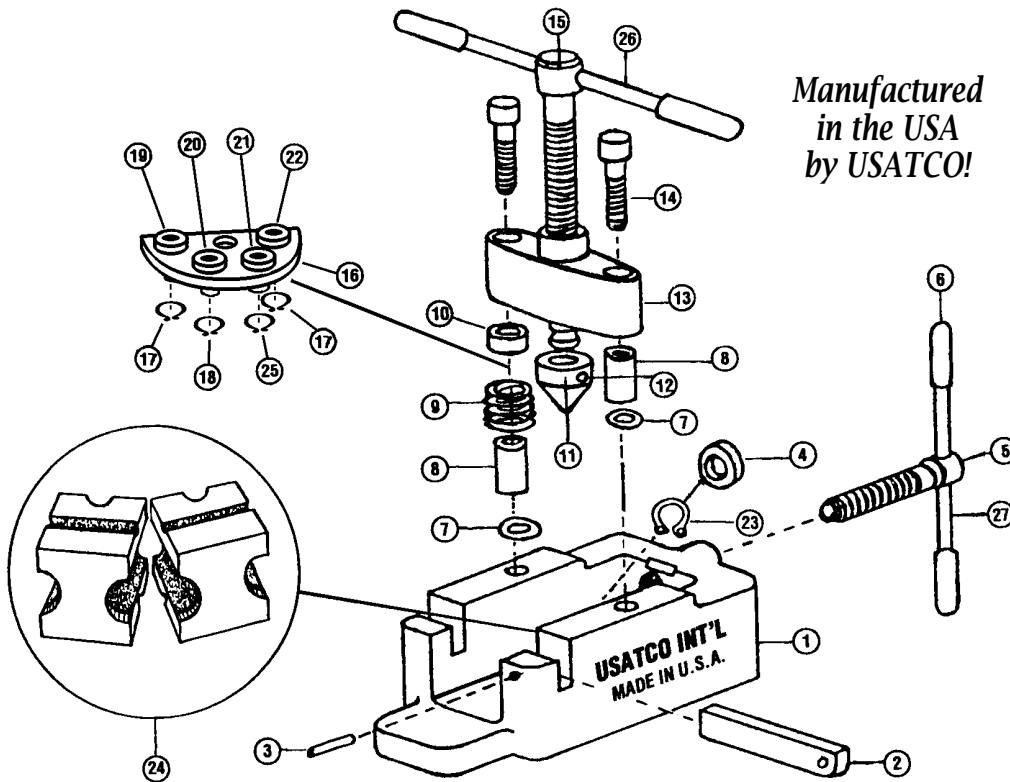

Index	Part No.	Description	Qty.
1	38-93013	Frame	1
2	38-93014	Gate	1
3	38-93015	Pivot Pin	1
4	38-93016	Contact Block	1
5	38-93017	Flare Block Screw	1
6	38-93018	Cap	4
7	38-93019	Spacer, Lower	2
8	38-93020	Post	2
9	38-93021	Spring	1
10	38-93022	Spacer, Upper	1
11	38-93023	Cone	1
12	38-93024	Lock Screw	1
13	38-93025	Bridge	1
14	38-93026	Lock Bolt	2
15	38-93027	Flare Screw	1

Index	Part No.	Description	Qty.
16	38-93028	Turret	1
17	38-93029	Retaining Ring	2
18	38-93030	Retaining Ring	1
19	38-93031	Flare Set - 5	1
20	38-93032	Flare Set - 6	1
21	38-93033	Flare Set - 8, 3	1
22	38-93034	Flare Set - 4	1
23	38-93035	Retaining Ring	1
24	38-93036	Tube Flare Block	2
25	38-93038	Retaining Ring	1
26	38-93039	T Handle Flare	1
27	38-93040	T Handle Flare	1
28	38-93041	Setting Gauges	4
—	—	—	—
—	—	—	—

Toll Free Nationwide & Canada: **800-645-8180**

USATCO\U.S. AIR TOOL COMPANY, INC. www.USATCO.com NEW YORK • CALIFORNIA

Instructions For Operation

Note: It is suggested that the user practice flaring according to the following instructions using scrap or spare tubing.

This precision Double Lap Flaring Tool provides a quick and convenient method making accurate 37° double & single flares which conform to aviation standard MS33583 on soft aluminum tubing. It can also be used for making single flares on soft aluminum tubing. Flares 3/16", 1/4", 5/16", 3/8", 1/2" O.D. tubing.

Before Making Flare, be sure end of tubing has been cut off squarely*, then remove burr from inside and outside edges**. Tubing should also be chamfered on the outside edge. The chamfer helps to guide the tubing in the first forming operation.

The clamping screw, compressor screw and adapter faces should be well lubricated at all times with an oil similar to S.A.E. 20.

To Make Double Lap Flares:

1. Affix TOOL TAB in vise.
2. Back off compressor screw sufficiently to enable adapter plate to clear (do not back off beyond this point).
3. Rotate the adapter plate into neutral position then open the latch bar and remove the die blocks as shown in **figure 1**.
4. Select the proper dies for the size of tubing to be flared and insert the blocks into the body of the tool. Then close the latch bar.
5. Select the adapter corresponding to the size of the tubing to be flared and rotate into position over opening in dies (note that sizes of adapter are marked on the top edge of the adapter plate).
6. Insert tubing in the opening of die blocks and continue pushing tube upward to a distance equal to the height of proper gauge which is marked

with the same identifier as the die blocks. Tighten clamping screw to hold tubing securely in this position.

7. Turn down compressor screw until bottom edge of the adapter is flush with the top of the die blocks (**figure 2**). This first operation prepares tubing for next step.

8. Retract compressor screw and rotate adapter carrier into neutral position. Again turn screw down firmly and double-flare is completed (**figure 3**). **Do not overtighten.**

9. To remove tubing after completing flare, loosen clamping screw and work tubing in a motion from clamp to latch and grip will be broken so that tubing can be slipped out.

10. burnish flared end with abrasive cloth. Form cloth into cone shape, rotate inside, on top and side of flare. Then **you must** thoroughly wash and blow out entire tube to remove any contaminant.

11. For making single flares, position adapter carries in neutral position, insert tubing approximately 1/32" to 1/16" above die blocks and clamp securely. Follow steps 6 and 7 above.

12. **It is extremely important** that the cone rotate freely during all phases of the flaring process. If frozen, loosen allen screw one turn and remove by backing out compressor screw until the cone detaches. Then clean up any burrs on screw end with fine emery cloth until cone fits on and rotates freely. Lubricate with a small amount of grease or oil. When tightening allen screw, do so lightly until contact is made with compressor screw end. Then, back off 1/2 turn to allow free rotation.

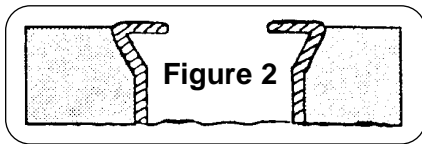
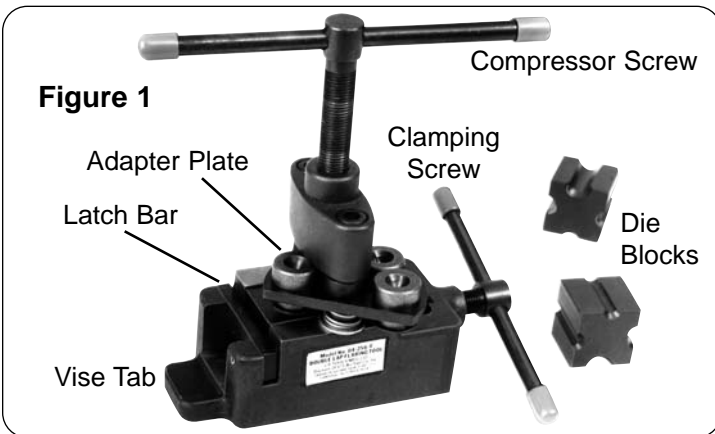

Caution
Clean tubing before installation. No oils or greases with oxygen lines!

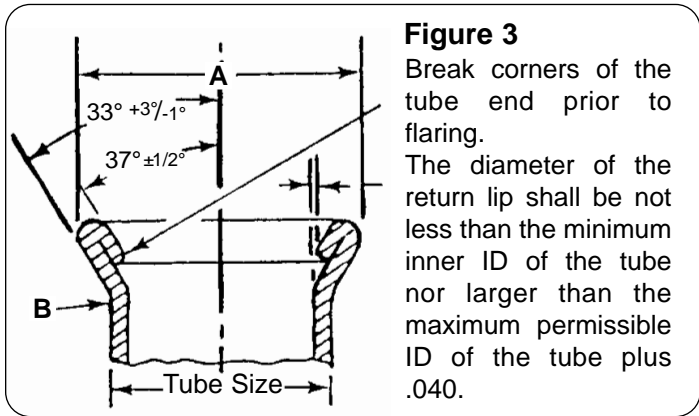
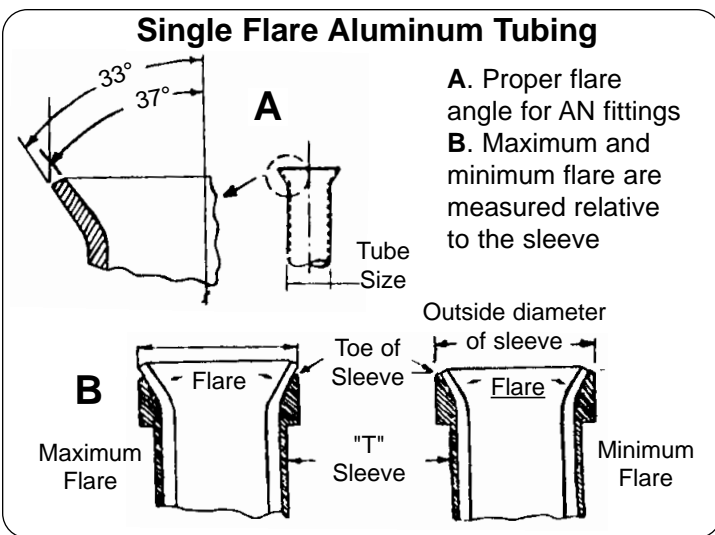

Figure 3
Break corners of the tube end prior to flaring. The diameter of the return lip shall be not less than the minimum inner ID of the tube nor larger than the maximum permissible ID of the tube plus .040.



Standard MS33583 Dimensions For 37° Double Flared Tubing

Tube Size Nominal O.D. In.	A +.000 -.010 Dia. Inches	B +.010 Radius Inches	Wall Thickness Inches	Minimum I.D. Inches
1/4"			.028"	.178"
			.035"	.159"
5/16"		.032"	.035"	.224"
			.049"	.198"
3/8"		.046"	.028"	.310"
			.035"	.288"
			.049"	.261"



*Use our Tubing Cutter, **02-0274**



Use our Inner Outer Reamer, **02-208-FSS

USATCO\U.S. Air Tool Company, Inc.

Eastern Division60 Fleetwood Ct., Ronkonkoma, NY 11779-6907 tel: (631) 471-3300 fax: (631) 471-3308

Western Division1219 W. Mahalo Place, Rancho Dominguez, CA 90220-5446 tel: (310) 632-5400 fax: (310) 632-3900