



DIMENSIONAL DATA (all measurements in Inches, see figure 1)

- Tool Weight (without riveter): 0.4 Lbs (0.181 Kg).

CHOICE OF RIVETERS

- **G704B** Cherry[®] Riveter;
- **G747** Cherry[®] Riveter
- **G750A** Cherry[®] Hand Riveter with adaptor 750A-088;

Note: May require double triggering when used with G747.

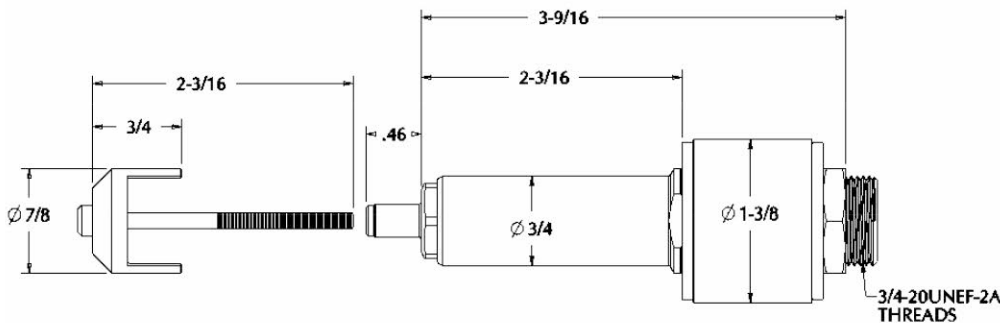

Figure 1

MOUNTING INSTRUCTIONS

- Attach riveter to air source for correct piston positioning; on the hand riveters, make sure that the pressure has been released and that the correct adaptors are used.
- Push against the riveter piston and thread pulling head onto both piston and housing of the riveter at the same time.
- DO NOT tamper with the jam nut, as it controls the removal load.

USAGE

- This tool was designed to remove rivetless nut plate fasteners installed in \varnothing 0.358/0.365 holes

BEFORE USE, MAKE SURE THAT:

- The correct removal tool is used and is properly mounted on the recommended riveter.
- Proper air source is connected (see riveter specification for recommended pressure).
- Make sure that the tool is clean and in good working condition
- Make sure that the nut is snug against the load control element (item 5); do not over-tighten.

DURING OPERATION

- Inspect the active area of the nosepiece regularly.
- Keep the tool clean, especially the nosepiece and jaws; pay special attention sealants are used.
- If stem slippage occurs, the jaws need to be either cleaned or replaced.

REMOVAL PROCESS

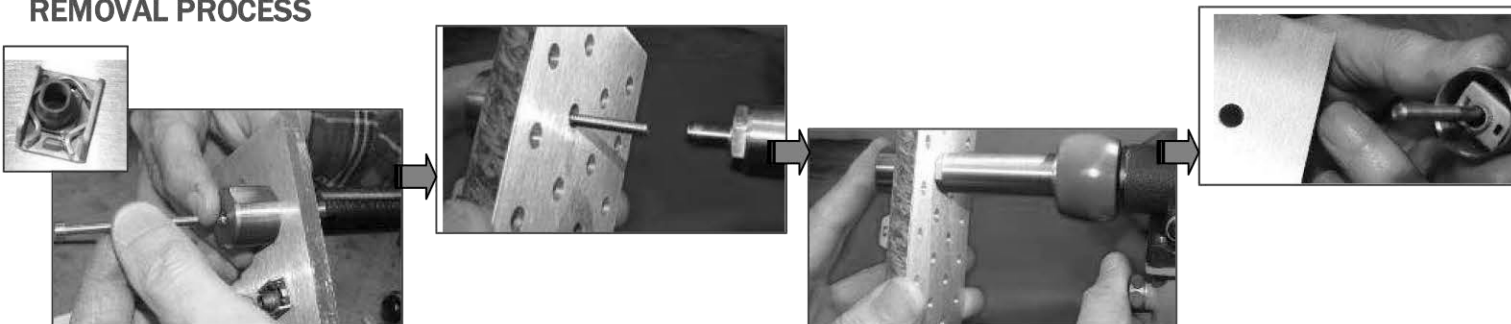

USATCO U.S. Air Tool Company, Inc.

Eastern Division60 Fleetwood Ct., Ronkonkoma, NY 11779-6907 tel: (631) 471-3300 fax: (631) 471-3308
Western Division1219 W. Mahalo Place, Rancho Dominguez, CA 90220-5446 tel: (310) 632-5400 fax: (310) 632-3900

Info@usatco.com

R721-5-12

RIVETLESS NUT PLATE REMOVAL TOOL

Technical Data Sheet, Page 2 of 2



CHERRY
AEROSPACE

PREVENTATIVE MAINTENANCE

- Clean the insert, jaws and jaw cavity every 1,000 installations, or whenever failures occurs.
- Lubricate outside configuration of the Jaws with Lubriplate® or similar light lubricant.
- Inspect regularly and keep the active area clean and in good working condition.
- Replace worn or broken components.
- At assembly, tighten jam nut (item 7) snug against the load control element (item 5). Do not over-tighten and use Loctite® to lock the jam nut in place.

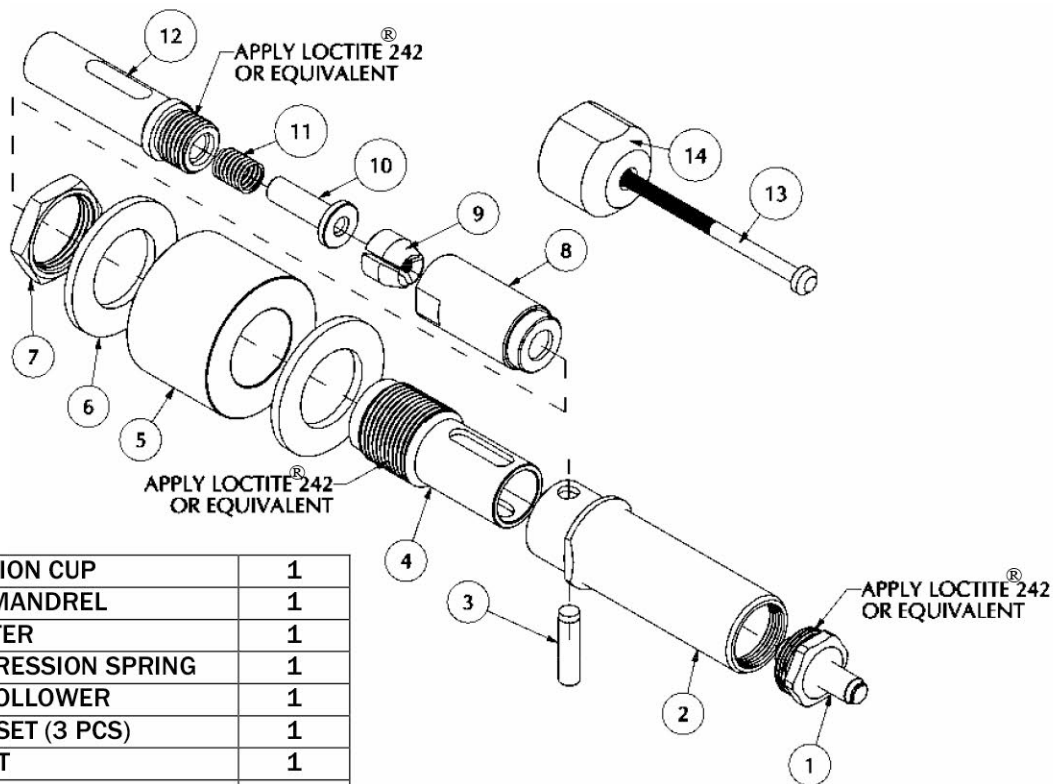

PARTS LIST

14	747-076	REACTION CUP	1
13	747-075	PULL MANDREL	1
12	747-088	ADAPTER	1
11	P-1423	COMPRESSION SPRING	1
10	747-049	JAW FOLLOWER	1
9	563C35	JAWS SET (3 PCS)	1
8	747-048	COLLET	1
7	671A16	JAM NUT	1
6	P-1437	WASHER	2
5	747-102	LOAD CONTROL ELEMENT	1
4	747-090	SLEEVE EXTENSION	1
3	P-143	DOWEL PIN	1
2	747-089	SLEEVE	1
1	747-098	NOSEPIECE, INSERT	1
ITEM NUMBER	PART NUMBER	DESCRIPTION	QTY. PER ASSY.

GENERAL / TECHNICAL QUESTIONS

1224 E. Warner Avenue
Santa Ana, CA 92705 USA
1-714-850-6022 (Phone)
1-714-850-6093 (Fax)

LOCTITE® is a registered trademark of Henkel Corporation.

LUBRIPLATE® is a registered trademark of Fiske Brothers Refining Co.

WARRANTY

Seller warrants the goods conform to applicable specifications and drawings and will be manufactured and inspected according to generally accepted practices of companies manufacturing industrial or aerospace fasteners. In the event of any breach of the foregoing warranty, Buyer's sole remedy shall be to return defective goods (after receiving authorization from Seller) for replacement or refund of the purchase price, at the Seller's option. Seller agrees to any freight costs in connection with the return of any defective goods, but any costs relating to removal of the defective or nonconforming goods or installation of replacement goods shall be Buyer's responsibility. SELLER'S WARRANTY DOES NOT APPLY WHEN ANY PHYSICAL OR CHEMICAL CHANGE IN THE FORM OF THE PRODUCT IS MADE BY BUYER. THE FOREGOING EXPRESS WARRANTY AND REMEDY ARE EXCLUSIVE AND ARE IN LIEU OF ALL OTHER WARRANTIES AND REMEDIES; ANY IMPLIED WARRANTY AS TO QUALITY, FITNESS FOR PURPOSE, OR MERCHANTABILITY IS HEREBY SPECIFICALLY DISCLAIMED AND EXCLUDED BY SELLER. This warranty is void if seller is not notified in writing of any rejection of the goods within ninety (90) days after receipt of the goods by buyer.

Seller shall not be liable under any circumstances for incidental, special or consequential damages arising in whole or in part from any breach by Seller, AND SUCH INCIDENTAL, SPECIAL, OR CONSEQUENTIAL DAMAGES ARE HEREBY EXPRESSLY EXCLUDED.

Our policy is one of continuous development. Specifications shown in this document may be subject to changes introduced after publication.

NOTE: The properties, strength, dimensions, installed characteristics and all other information in these materials are for guidance only to aid in the correct selection of the products described herein and is not intended or implied as part of the above warranty. All applications should be evaluated for functional stability and available samples of the described parts can be requested for installed tests, suitability and evaluations.

For more information please contact our Technical Services Department at tel. 714-850-6022

USATCO U.S. Air Tool Company, Inc.

Info@usatco.com

Eastern Division60 Fleetwood Ct., Ronkonkoma, NY 11779-6907 tel: (631) 471-3300 fax: (631) 471-3308

Western Division1219 W. Mahalo Place, Rancho Dominguez, CA 90220-5446 tel: (310) 632-5400 fax: (310) 632-3900