



# G747

Lightweight CherryMAX® Power Tool



**CHERRY®**  
AEROSPACE

 Instruction Manual   
Pass on to user to read and keep for reference

# MANUAL



USATCO U.S. Air Tool Company, Inc.

Eastern Division .....60 Fleetwood Ct., Ronkonkoma, NY 11779-6907 tel: (631) 471-3300 fax: (631) 471-3308  
Western Division .....1219 W. Mahalo Place, Rancho Dominguez, CA 90220-5446 tel: (310) 632-5400 fax: (310) 632-3900

**Info@usatco.com**

# TABLE OF CONTENTS

Description .....	2
Specifications for G747 .....	2
Safety Warnings .....	3
How to Use the G747 .....	4
Maintenance and Repair .....	4
Fill and Bleed Instructions .....	5
Trouble Shooting .....	5
Overhaul .....	6
Air Valve .....	6
Head Sub-Assembly .....	6
Handle Sub-Assembly .....	6
Pulling Heads .....	7
Cross Section Drawing Of G747 .....	8
Parts List for G747 Riveter .....	9
Exploded View of G747 .....	10
Declaration of conformity .....	Back Cover

# DESCRIPTION

The Cherry® G747 is a pneumatic-hydraulic tool designed specifically for the most efficient installation of CherryMAX® rivets and nut-plate rivets but not limited to them. A durable, all metal housing makes this extremely robust tool ideal for use in rugged shop environments. It has many ergonomic features: very light weight, comfortable fit in the operators hand and it can be operated in any position with one hand. This tool utilizes straight, offset and right-angle pulling heads, all of which can install -4, -5, and -6 diameter CherryMAX® bulb type rivets in all head styles, materials and grip lengths. Extensions are available for extending the pulling heads to reach limited access areas. See the section on pulling heads for the correct pulling head part number.

## SPECIFICATIONS FOR G747

Cherry® Aerospace (CHERRY®) policy is one of continuous development. Specifications shown in this document may be subject to change which may be introduced after publication. For the latest information always consult CHERRY®.

AIR PRESSURE	90 PSI (6.2 bar) Min. / 110 PSI (7.6 bar) Max.
STROKE	0.437 inch (11.1 mm)
PULLING FORCE	2100 Pounds (9.34 kN) @ 90 PSI (6.2 bar)
CYCLE TIME	Approximately One Second
WEIGHT	3.5 Pounds (1.59 kg)
NOISE LEVEL	71 dB (A)
VIBRATION	less than 2.5 m/s <sup>2</sup>
AIR CONSUMPTION	0.09 SCF/cycle (2.55 L/cycle)

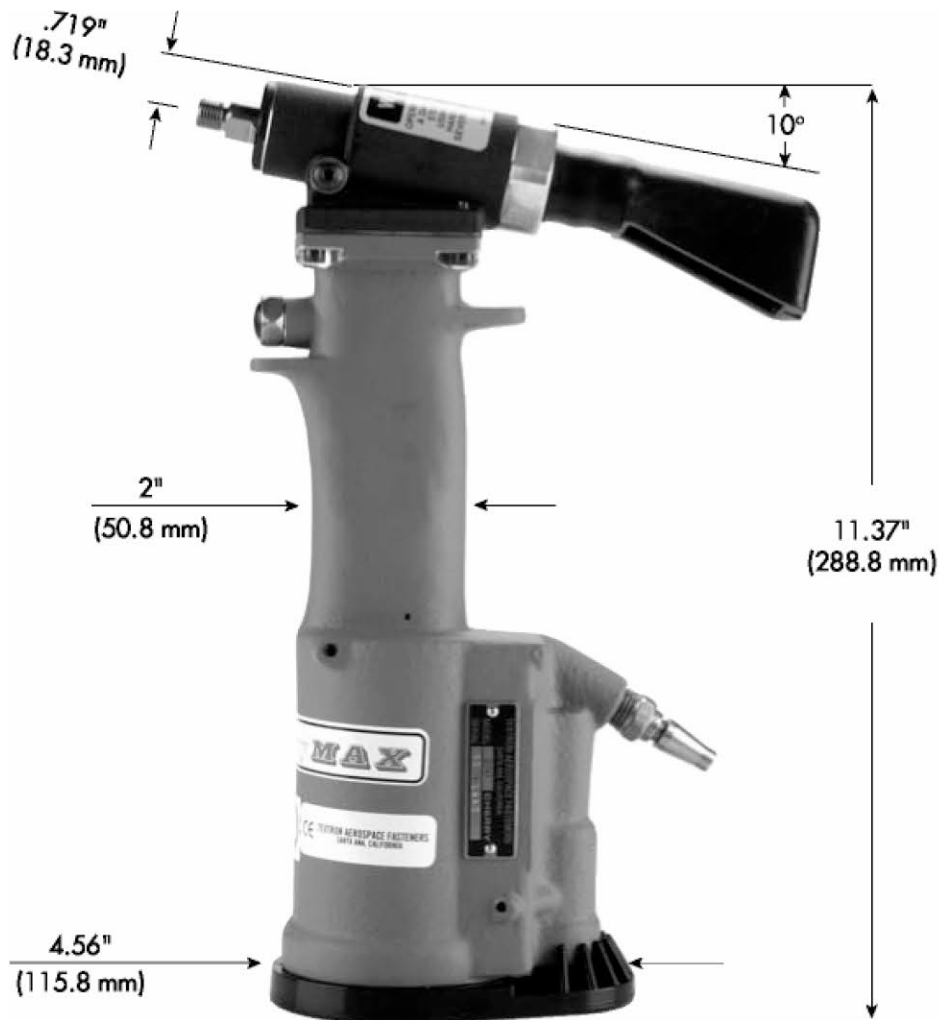

## SAFETY WARNINGS

- Operating this tool with a damaged or missing stem deflector, or using the deflector as a handle, may result in severe personal injury. The pin deflector should be rotated until the aperture is facing away from the operator and other persons working in the vicinity.
- Approved eye protection should be worn when operating, repairing, or overhauling this tool.
- Do not use beyond the design intent.
- Do not use substitute components for repair.
- Any modification to the tool, pulling heads, accessories or any component supplied by CHERRY®, or their representatives, shall be the customer's entire responsibility.  
**CHERRY® will be pleased to advise on any proposed modification.**
- The tool must be maintained in a safe working condition at all times and examined at regular intervals for damage.
- Before disassembling the tool for repair, refer to the maintenance instructions. All repairs shall be undertaken only by personnel trained in CHERRY/Cherry installation tools.  
**Contact CHERRY® with your training requirement.**
- Always disconnect the air line from the tool inlet before attempting to service, adjust, fit or remove any accessory.
- Do not operate the tool when it is directed at any person.
- Ensure that the vent holes do not become blocked or covered and that air line hoses are always in good condition.
- Excessive contact with the hydraulic oil should be avoided to minimize the possibility of rashes. Care should be taken to wash thoroughly.
- Operating air pressure should not exceed 110 psi (7.6 bar).
- Do not operate the tool without the pulling head in place.
- Do not operate the tool unless the handle base (25) is fully secured by the retaining rings (26) and (28) and base cover (27).
- All retaining rings, screwed end caps, air fittings, trigger valves and pulling heads should be attached securely and examined at the end of each working shift.
- Do not pull rivet in the air.
- The precautions to be used when using this tool must be explained by the customer to all operators.  
**Any questions regarding the correct operation of the tool and operator safety should be directed to CHERRY.**
- Do not pound on the rear of the tool head to force rivets into holes as this will damage the tool.
- Do not depress the trigger while disconnecting the air bleeder and replacing the cap screw when bleeding the tool.

# HOW TO USE THE RIVETER

After selecting the proper pulling head and attaching it securely to the riveter, connect the tool to an air line. Recommended air pressure is between 90 and 110 psi. Insert the rivet stem into the pulling head until the head of the rivet is in contact with the nosepiece. This will ensure full engagement between the jaws and the rivet stem and preventing slippage.

Insert the rivet into the application and depress the trigger to activate the tool. Upon the release of the trigger, the stem will eject to the rear of the tool when straight, pulling heads with no side eject feature are used. Other pulling heads (offset, right angle) will either captivate the stem or allow stem removal through the front only. See the appropriate tooling sheet for the selected pulling head.

If unclear, contact a CHERRY® representative.

## MAINTENANCE AND REPAIR

The G747 has been manufactured to give maximum service with minimum care. In order that this may be accomplished, the following recommendations should be followed:

1. The hydraulic system should be full of oil and free from air at all times.
2. Keep excessive moisture and dirt out of air supply to prevent wear of air valve, air cylinder and air piston.
3. Tool should be routinely inspected for oil leaks.

Use automatic transmission fluid Type "A" (no substitutes). CHERRY® recommends using Dexron® III ATF.

## DEXRON III OIL SAFETY DATA

### FIRST AID

*Skin:* Wash thoroughly with soap and water as soon as possible. Casual contact requires no immediate attention. If irritation develops, consult a physician.

*Ingestion:* Seek medical attention immediately. DO NOT INDUCE VOMITING.

*Eyes:* Flush with copious amounts of water. If irritation develops, consult a physician.

*Inhalation:* No significant adverse health effects are expected to occur on short term exposure. Remove from contaminated area. Apply artificial respiration if needed. If unconscious, consult physician.

### FIRE

*Suitable extinguishing media:* CO<sub>2</sub>, dry powder, foam or water fog. DO NOT use water jets.

### ENVIRONMENT

*Waste Disposal:* In accordance with local, state and federal regulations.

*Spillage:* Prevent entry into drains, sewers and water courses. Soak up with diatomaceous earth or other inert material. Store the spent fluid in appropriate containers for disposal.

### HANDLING

Eye protection required. Protective gloves recommended. Chemically resistant boots and apron recommended. Use in well ventilated area.

### COMBUSTIBILITY

It is slightly combustible when heated above flash point. It will release flammable vapors which can burn in open or be explosive in confined spaces if exposed to source of ignition.

### STORAGE

Avoid storage near open flame or other sources of ignition.

### PROPERTIES

<i>Specific gravity</i>	0.863
<i>Weight per gallon</i>	7.18 lbs.
<i>Open flash point</i>	>200°C (392°F)

# FILL AND BLEED INSTRUCTIONS

To replace a small amount of oil in the tool, remove cap screw (14), attach the Cherry air bleeder (700A77), connect the tool to the air line and cycle several times. This will ensure the removal of any air from the hydraulic system and its replacement with fluid.

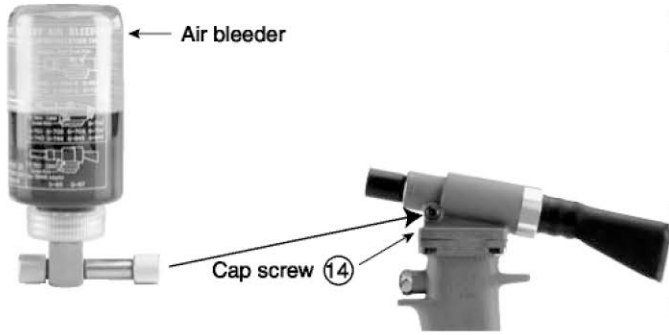

Should it become necessary to completely refill the tool (such as would be required after the tool has been dismantled and re-assembled), take the following steps?

1. Remove head assembly (1) from handle (31) by unscrewing cap screws (50).
2. Fill handle assembly (31) with the recommended oil to within 1/8" (3.175mm) of the top of the handle casting.
3. Place head assembly (1) on handle (31), being sure gasket (49), and O-ring (48), are properly in place. Tighten cap screws (50) uniformly to prevent leakage around gasket.
4. Remove cap screw (14) and attach the Cherry air bleeder (700A77). Connect the tool to the air line and cycle a number of times. This will ensure the removal of any air from its hydraulic system and its replacement with fluid.

## TROUBLESHOOTING

1. Check the air line for correct pressure at the tool. It must be 90 to 110 psi (6.2 to 7.6 bar).
2. Check the tool for lack of oil (see Fill and Bleed instructions).
3. Check for oil leakage:
  - Oil leaking around the cap screw (14) in the head indicates that the screw is loose or the Stat-O-Seal (13) needs replacing.
  - If oil should leak through the by-pass hole at the base of the handle (31) the O-rings (33) are worn or damaged.
  - Oil leaking from the front of the head (1) indicates that O-rings (2) are worn or damaged.
4. Check for excessive air leakage from the air valve:
  - If spring (39) is broken or dislodged, air will bleed directly through the bottom of the air valve and the head piston retreats to its full stroke without returning. See air valve instructions on page 6.
  - If O-ring (44) on plug (45) is worn or damaged, replace.
  - If O-rings (35) on valve spool (41) are worn or damaged, replace.
5. Check movement of the head piston (4). If it does not move freely or is slow in operation:
  - O-rings (2), (5) and (7) may be damaged and require replacement.
  - Head piston (4) may be mechanically locked due to damaged parts.
  - The O-ring (35) on power piston rod (36) may be damaged; replace.
  - Muffler (46) or air filter (42) inside valve spool (41) may be plugged with dirt. Clean them thoroughly with normal solvent and back-blow with compressed air.
  - Hole in metering screw (42) in valve spool (41) may be blocked or damaged. Hole diameter should be .028" (.7112 mm). Clear and size or replace valve spool assembly (40).
6. Rivet stem sticks in the pulling head:
  - Pulling head components need maintenance. Disassemble the pulling head, clean and replace worn parts. Reassemble following instructions given in the corresponding Tool Sheet.
  - Spent rivet stems are wedged side by side in the pulling head. Disassemble the pulling head, remove stems and re-assemble following instructions given in the corresponding Tool Sheet.

USATCO U.S. Air Tool Company, Inc.

Eastern Division .....60 Fleetwood Ct., Ronkonkoma, NY 11779-6907 tel: (631) 471-3300 fax: (631) 471-3308  
Western Division .....1219 W. Mahalo Place, Rancho Dominguez, CA 90220-5446 tel: (310) 632-5400 fax: (310) 632-3900

**Info@usatco.com**

# OVERHAUL

# G701/G704KT TOOL KIT

The disassembly and re-assembly procedures can be accomplished by following the instructions below and the drawings on pages 8 & 10. **Use extreme care during disassembly and re-assembly not to mar, nick or burr any smooth surface that comes in contact with O-rings.** Before installing O-rings, be sure to apply an O-ring lubricant. It is recommended that special assembly tools, which can be ordered under part number **G701/G704KT**, be used to overhaul this tool. Service kit, **G747KS**, which contains a complete set of O-rings, back-up rings, screws, washers and gaskets should be ordered.



836B700  
Valve Spring Installation Tool



837B700  
Valve Sleeve Removal Tool



700A62  
Power Cylinder Tool



700A61  
Piston Rod Wrench

**Not shown, but included:** 701A67 Seal Guide, 702B62 Power Cylinder Tool, 703A53 Seal Guide, 702A64 Seal Guide.



700B65  
Packing Plug Wrench



P1178  
Valve Plug Extractor



700A60  
Seal Guide



700A77  
Air Bleeder

## AIR VALVE

- Remove retaining ring (47) and muffler (46). Insert a valve plug extractor (P1178) into end of valve plug (45) and pull it out. Using the same procedures, pull out valve spool sub-assembly (40).
- Use needle nose pliers to grasp the end of the spring (39), turn clockwise and pull out to dislodge from groove in handle.
- With spring removed, valve sleeve (38) can be pulled out using the valve sleeve removal tool (837B700).

To re-assemble, reverse the above procedures, being certain that all O-rings are properly lubricated. To avoid damaging the O-rings (37), carefully install sleeve (38) with your finger. Gently push and wiggle sleeve to allow O-rings to slip past inner ports. Spring (39) is best installed using a valve spring installation tool (836B700) to push the large diameter coil into the groove. This requires care as the tool will not operate if the spring is not anchored firmly.

## HEAD SUB-ASSEMBLY

- Disconnect the air supply and remove the complete pulling head from the tool before attempting to disassemble the head assembly.
- Remove the four socket head cap screws (50). Lift head assembly from the handle (31). Remove O-ring (48) and gasket (49). Empty the oil into a container by pouring from the handle. Dispose of the oil according to environmental regulations.
- Remove end cap (9). Push against threaded end of head piston (4) and slide it out of head cylinder (1). Be careful not to damage threads or cause burrs on polished head piston rod surface.
- O-rings (2) and back-up ring (3) can now be removed using a bent hook. O-ring (7) can be removed in the same manner.
- Upon re-assembly, be sure to install O-rings and back-up rings carefully to avoid cutting them. Always lubricate all O-rings. Just prior to placing the head sub-assembly onto the handle, see Fill and Bleed Instructions. Also make sure to place O-ring (51) on top of the handle in its groove, and then the gasket (49) over the O-ring (48).
- Tighten the four socket head cap screws (50) uniformly to prevent leakage around the gasket.
- Purge system of air using Cherry air bleeder (700A77) according to Fill & Bleed Instructions.

## HANDLE SUB-ASSEMBLY

- Disconnect tool from air supply and remove parts (24) through (28).
- Remove the head sub-assembly using the instructions in the head sub-assembly section.
- Place piston rod wrench (700A61) down into the top of the handle (31), into the hex socket in the head of the power piston rod (36). While holding this wrench, remove the locknut (23) using the 7/16" socket in packing plug wrench (700B65).
- Still holding the piston rod wrench, remove the air piston (21) using the packing plug wrench (700B65) by turning counterclockwise. When air piston is completely freed from the piston rod, tap or push on the piston rod wrench to eject the piston from bottom of handle.
- Slide power piston rod rod (36) back up to the end of its travel. Using the packing plug wrench (700B65), remove packing plug (18). It may be necessary to hold the handle upside down in a vise while removing the packing plug.
- Power cylinder (32) can be tapped out by lowering power cylinder tool (700A62) down into the top of the handle on to top of cylinder. The O-rings (15) and backup rings (16) are best removed and replaced by using a thin bent hook.

To re-assemble the handle, reverse the above procedure, being certain that all the O-rings are properly lubricated before installation. Attach the seal guide (700A60) to the piston rod (36) and with a mallet, tap the piston rod through the packing plug (18). When re-assembling a replacement air piston, items (19) through (22), follow the instructions given below:

- Clamp piston rod wrench (700A61) in a vise with the hex shaft pointed up.
- Turn the handle upside down and place the hex end of the power piston rod (36) onto the wrench. Push handle casting down until it stops.
- Assemble seal (19) to air piston (21).
- Place large washer (20) over the threaded end of the power piston rod (36).
- Place the air piston (21) into handle bore. **IMPORTANT:** Be sure that the radial pattern embossed on the side of air piston is facing downward towards the large washer (20) and the smooth side of the air piston is facing you.
- Place the small washer (22) over the threaded end of the power piston rod (36). Thread the locknut (23) onto the power piston rod sub-assembly (36) and tighten between 50 in-lb (5,65 N-m) and 59 in-lb (6,67 N-m).

## G747 PULLING HEADS

Pulling Heads are not furnished with riveter and must be ordered separately.

See the Tool Sheet. for mounting, maintenance and operation instructions of particular pulling heads.

Pulling Head	Type	Adapter	Rivet	Rivet Diameters	Maximum Grip <sup>1</sup>
H701 B-456	Straight	-	CherryMAX® Bulb	1/8, 5/32, 3/16 <sup>2,3</sup>	All
			CherryMAX® "A"	1/8, 5/32, 3/16 <sup>3</sup>	-3 <sup>1</sup>
			InterMAX	1/8, 5/32, 3/16	-3 <sup>1</sup>
H747-3NPR	Straight	-	Nut-plate	3/32	All
H753A-456	Right Angle	-	CherryMAX® Bulb	1/8, 5/32, 3/16 <sup>2,3</sup>	All
			CherryMAX® "A"	1/8, 5/32, 3/16 <sup>3</sup>	-3 <sup>1</sup>
			InterMAX	1/8, 5/32, 3/16	-3 <sup>1</sup>
H781-456	Offset	-	CherryMAX® Bulb	1/8, 5/32, 3/16 <sup>2,3</sup>	All
			CherryMAX® "A"	1/8, 5/32, 3/16 <sup>3</sup>	-3 <sup>1</sup>
			InterMAX	1/8, 5/32, 3/16	-3 <sup>1</sup>
H9015	Straight	704A9	MS <sup>4</sup>	3/32, 1/8, 5/32, 3/16	All
H955	Straight	-	CherryLock® "A"	3/32, 1/8, 5/32, 3/16	-3 <sup>1</sup>

<sup>1</sup>. On the first stroke.

<sup>2</sup>. Nominal and oversize.

<sup>3</sup>. No 3/16 aluminum, Alloy steel and Monel only.

<sup>4</sup>. Serrated stems only.



# CROSS SECTION OF G747

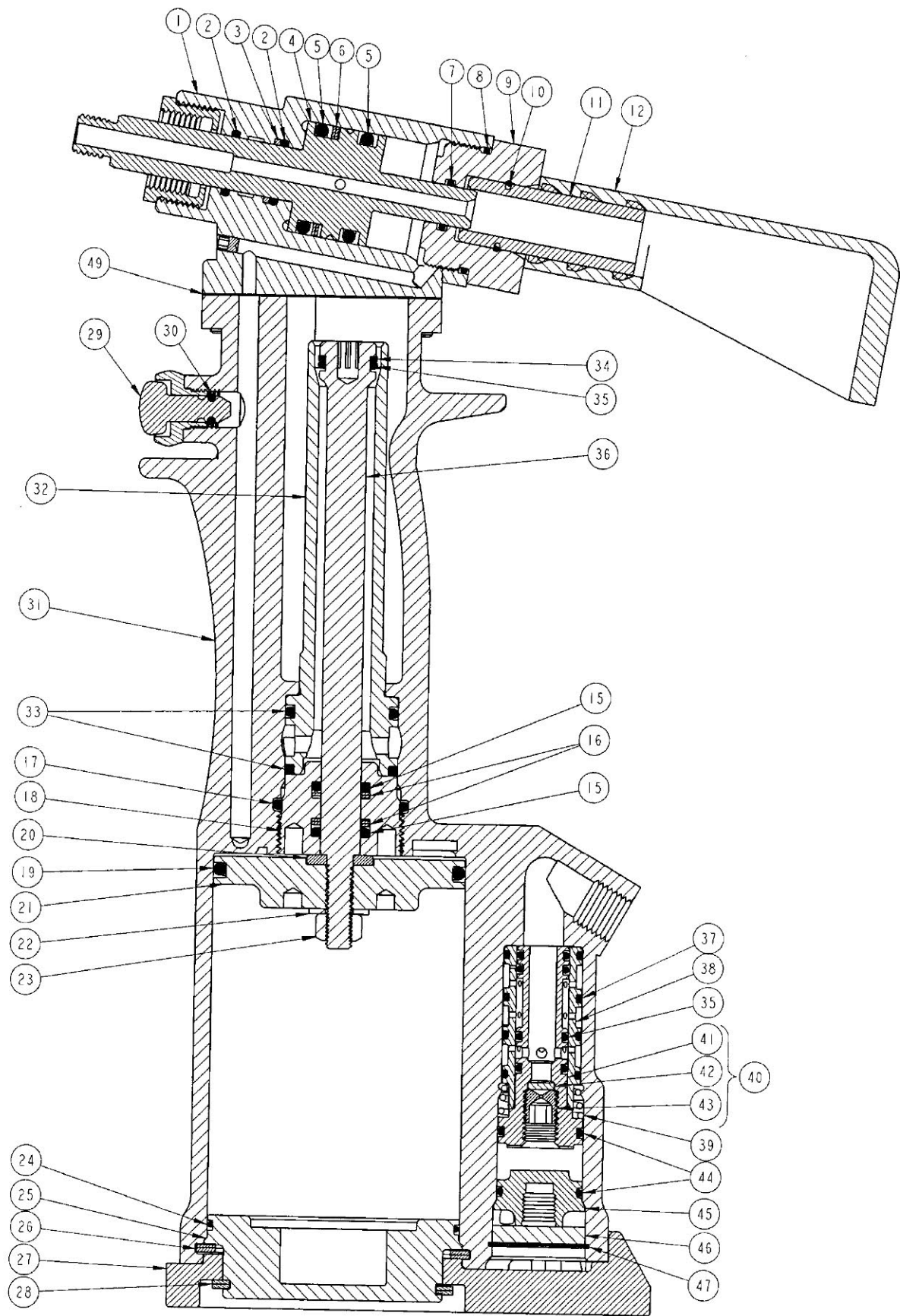

# PART LIST FOR THE G747 (747-002) CHERRYMAX RIVETER ASSEMBLY

ITEM	PART NO.	DESCRIPTION	QTY	
747-002 (G747 RIVER ASSEMBLY)				
747-004 SUB-ASSEMBLY, HEAD				
1	747-020	SUB -ASSEMBLY, HEAD CYLINDER	1	
2	P-701	O-RING (.629, .489, .070)	2	
3	P-998	RING, BACK-UP (.609, .503, .053)	1	
4	747-009	PISTON, HEAD	1	
5	P-107	O-RING (1.074, .796, .139)	2	
6	P-108	RING, BACK-UP (1.054, .812, .121)	1	
7	P-112	O-RING (.504, .364, .070)	1	
8	P-690	O-RING (1.129, .989, .070)	1	
9	747-016	CAP, HEAD CYLINDER	1	
10	P-880	RING, RETAINING (NON-STANDARD)	1	
11	703A13	FITTING, DEFLECTOR	1	
12	530A16	DEFLECTOR, PIN	1	
13	P-572	STAT-O-SEAL (.443, .180, .132)	1	
14	P-573	SCREW, BUTTON HEAD CAP, 10-32 X 1/4	1	
747-005 SUB-ASSEMBLY, HANDLE				
15	P-838**	O-RING, DISOGRIN (.568, .362, .103)**	2	
16	P-115	RING, BACK-UP (.551, .375, .088)	2	
17	P-727	O-RING (1.318, 1.112, .103)	1	
18	700B93	PLUG, PACKING	1	
19	P-893	O-RING (2.387, 2.109, .139)	1	
20	700A21	WASHER	1	
21	747-013	PISTON, AIR	1	
22	P-1387	WASHER	1	
23	P-737	NUT, CONELOK, 1/4-20	2	
24	P-894	O-RING (2.254, 2.114, .070)	1	
25	747-015	BASE, HANDLE	1	
26	P-895	RING, RETAINING (INT. Ø 2.440)	1	
27	747-011	COVER, URETHANE BASE	1	
28	P-1386	RING, RETAINING (EXT. Ø 2.062)	1	
29	703A33	SUB ASSEMBLY, TRIGGER (INCLUDES P-223)	1	
	30	1 P-223 O-RING (.285, .145, .070)	1	
31	747-018	HANDLE	1	
32	747-019	CYLINDER, POWER	1	
33	P-833	O-RING, DISOGRIN (1.068, .862, .103))	2	
34	P-919**	RING, BACK-UP (.528, .422, .053)	1	
35	P-829**	O-RING, DISOGRIN (.504, .364, .070)	5	
36	747-017	ROD, PISTON	1	
37	P-653	O-RING (.691, .551, .070)	4	
38	700B96	SLEEVE, VALVE	1	
39	700A67	SPRING	1	
40	700A94	SUB-ASSEMBLY, VALVE SPOOL 1	1	
	41	700B95*	VALVE SPOOL	1
	42	700A18*	FILTER	1
	43	700A69*	SCREW METERING	1
44	P-834**	O-RING, DISOGRIN (.816, .676, .070)	2	
45	700A16	PLUG, VALVE	1	
46	700A17	MUFFLER	1	
47	P-279	RING, RETAINING (INT. Ø .906)	1	
48	P-832**	O-RING, DISOGRIN (.379, .239, .070)	1	
49	702A22	GASKET	1	
50	P-27	SCREW, SOC. HD. CAP, 8-32 X 1/2	4	
51	670A20***	BAG, STEM CATCHER	1	
52	P-984***	HOSE, AIR	1	

\* These parts cannot be purchased separately, but must be ordered as a sub-assembly.

\*\* No substitutions.

\*\*\* Not furnished with riveter. Must be ordered separately if desired.

# EXPLODED VIEW OF G747

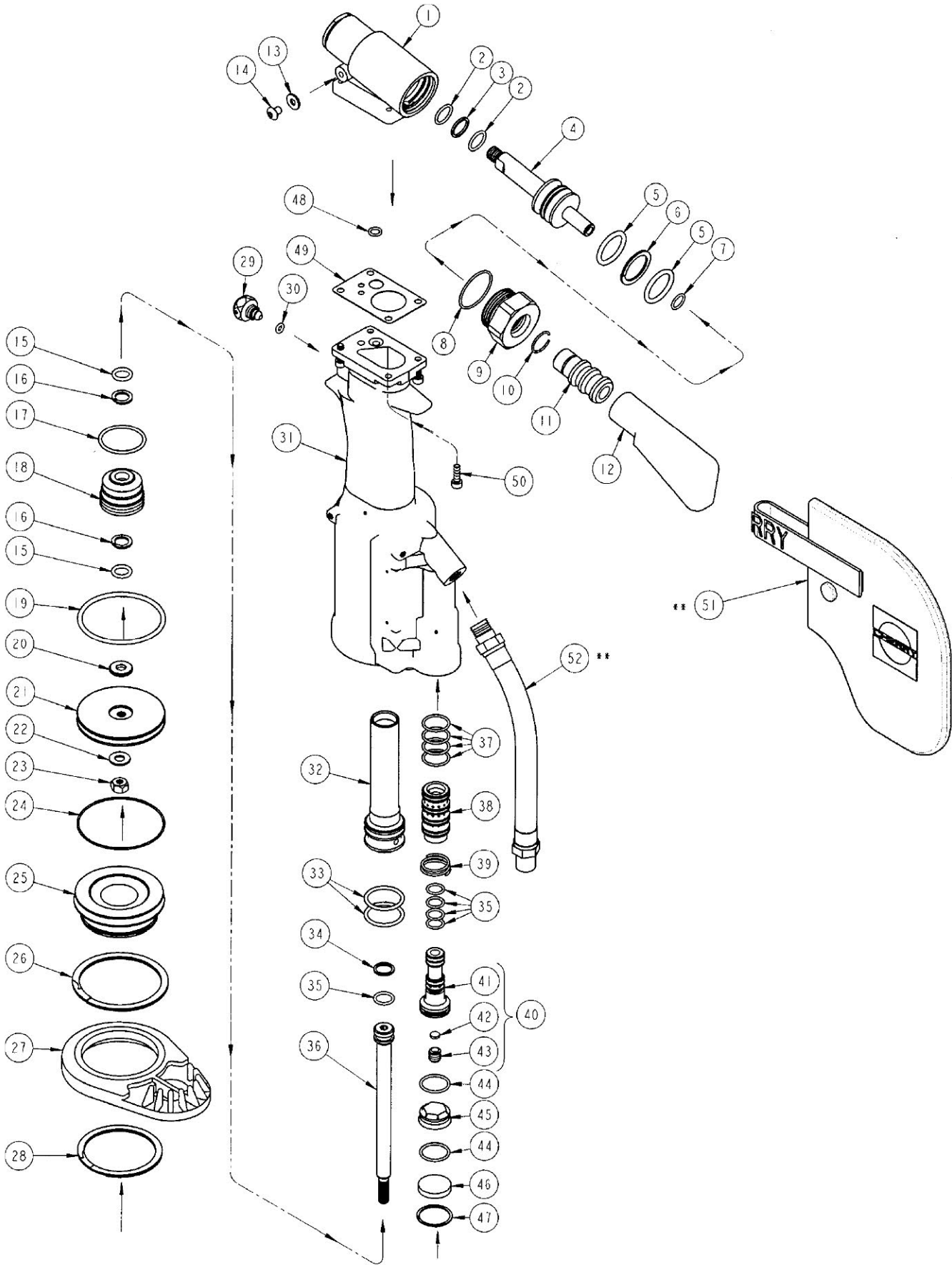

# Declaration of Conformity

We, Cherry® Aerospace, 1224 E. Warner Ave., Santa Ana, CA 92705

declare under our sole responsibility that the product

type **G747**

Serial No.-

to which this declaration relates is in conformity with the following standards

EN292 part 1 and part 2  
ISO 8662 Part 1  
ISO 3744

following the provisions of the Machine Directive 89/392/EEC  
(as amended by Directive 91/368/EEC) and 93/68/EEC

Santa Ana, CA -  
date of issue

Original certification and signatures on file

## WARRANTY

Seller warrants the goods conform to applicable specifications and drawings and will be manufactured and inspected according to generally accepted practices of companies manufacturing industrial or aerospace fasteners. In the event of any breach of the foregoing warranty, Buyer's sole remedy shall be to return defective goods (after receiving authorization from Seller) for replacement or refund of the purchase price, at the Seller's option. Seller agrees to any freight costs in connection with the return of any defective goods, but any costs relating to removal of the defective or nonconforming goods or installation of replacement goods shall be Buyer's responsibility. SELLER'S WARRANTY DOES NOT APPLY WHEN ANY PHYSICAL OR CHEMICAL CHANGE IN THE FORM OF THE PRODUCT IS MADE BY BUYER.

THE FOREGOING EXPRESS WARRANTY AND REMEDY ARE EXCLUSIVE AND ARE IN LIEU OF ALL OTHER WARRANTIES AND REMEDIES; ANY IMPLIED WARRANTY AS TO QUALITY, FITNESS FOR PURPOSE, OR MERCHANTABILITY IS HEREBY SPECIFICALLY DISCLAIMED AND EXCLUDED BY SELLER. THIS WARRANTY IS VOID IF SELLER IS NOT NOTIFIED IN WRITING OF ANY REJECTION OF THE GOODS WITHIN ONE (1) YEAR AFTER INITIAL USE BY BUYER OF ANY POWER RIVETER OR NINETY (90) DAYS AFTER INITIAL USE OF ANY OTHER PRODUCT.

Seller shall not be liable under any circumstances for incidental, special or consequential damages arising in whole or in part from any breach by Seller, AND SUCH INCIDENTAL, SPECIAL, OR CONSEQUENTIAL DAMAGES ARE HEREBY EXPRESSLY EXCLUDED.

For more information please contact our Technical Services Department at Tel. 714-850-6022

LOCTITE® is a registered trademark of Henkel Corporation  
DEXRON® is a registered trademark of GM corporation.  
PARKER® is a trademark of Parker Hannifin Corporation  
LUBRRIPATE® is a trademark of Fiske Brothers Refining Co.



**USATCO U.S. Air Tool Company, Inc.**

**Eastern Division** .....60 Fleetwood Ct., Ronkonkoma, NY 11779-6907 tel: (631) 471-3300 fax: (631) 471-3308  
**Western Division** .....1219 W. Mahalo Place, Rancho Dominguez, CA 90220-5446 tel: (310) 632-5400 fax: (310) 632-3900

**Info@usatco.com**