



**CHERRYMAX® TOOLING ACCESSORIES**

**753B21 NOSE EXTENSION**



The 753B21 Nose Extension provides a 1-1/8" extension to the nosepiece of the H753A-456 CherryMAX right angle pulling head.

**INSTALLING 753B21 EXTENSION ON PULLING HEAD**

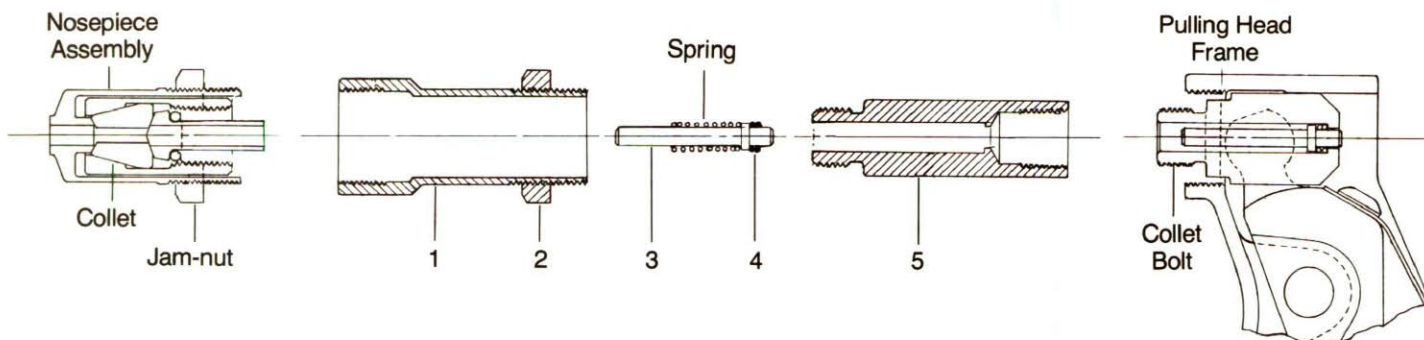

1. Remove nosepiece assembly from frame of pulling head.
2. Engage internal threads of the collet extension (5) with external threads of the collet bolt. Rotate collet extension (5) clockwise until snug and tighten with appropriate wrench.
3. Engage external threads of sleeve extension (1) with internal threads of pulling head frame. Rotate sleeve extension (1) clockwise until handtight. Tighten jam-nut (2) snugly against frame with wrench.
4. Insert spring from nosepiece assembly over stem stop (3) with O-rings (4), inside the collet extension (5).
5. Engage internal threads of nosepiece collet to external threads of collet extension (5). Jaws and jaw follower should already be inserted in nosepiece collet. Rotate nosepiece collet clockwise until snug and tighten with appropriate wrench.
6. Engage external threads of nosepiece sleeve with internal threads of the sleeve extension (1). Rotate nosepiece sleeve clockwise until hand tight. Tighten nosepiece jam-nut snugly with wrench.

**NOTE:** Loc-tite Type 242, or equivalent, should be used on all threads prior to tightening with wrenches.

USATCO U.S. Air Tool Company, Inc.

**Info@usatco.com**

Eastern Division .....60 Fleetwood Ct., Ronkonkoma, NY 11779-6907 tel: (631) 471-3300 fax: (631) 471-3308  
 Western Division .....1219 W. Mahalo Place, Rancho Dominguez, CA 90220-5446 tel: (310) 632-5400 fax: (310) 632-3900



**753B21 NOSE EXTENSION**

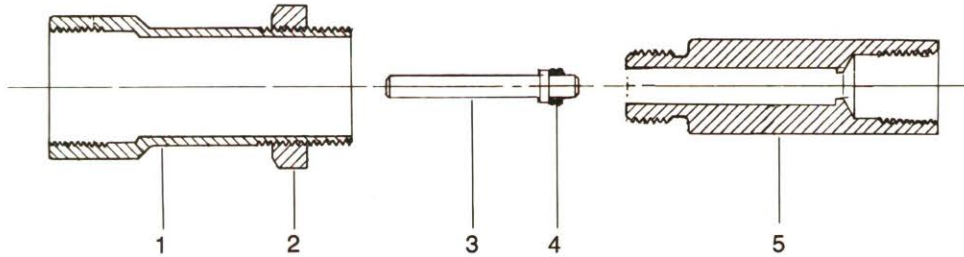

REF NO.	PART NUMBER	DESCRIPTION	QTY. REQ.
1	753B23	Sleeve Extension	1
2	G6JN	Jam Nut	1
3	753A15	Stem Stop	1
4	P-706	O-ring	2
5	753B22	Collet Extension	1

**MAINTENANCE AND REPAIR**

Keep nose extension clean, especially inner section of sleeve extension, as chips and sealants can hamper internal operation.

**WARRANTY**

Seller warrants the goods conform to applicable specifications and drawings and will be manufactured and inspected according to generally accepted practices of companies manufacturing industrial or aerospace fasteners. In the event of any breach of the foregoing warranty, Buyer's sole remedy shall be to return defective goods (after receiving authorization from Seller) for replacement or refund of the purchase price, at the Seller's option. Seller agrees to any freight costs in connection with the return of any defective goods, but any costs relating to removal of the defective or nonconforming goods or installation of replacement goods shall be Buyer's responsibility. SELLER'S WARRANTY DOES NOT APPLY WHEN ANY PHYSICAL OR CHEMICAL CHANGE IN THE FORM OF THE PRODUCT IS MADE BY BUYER. THE FOREGOING EXPRESS WARRANTY AND REMEDY ARE EXCLUSIVE AND ARE IN LIEU OF ALL OTHER WARRANTIES AND REMEDIES; ANY IMPLIED WARRANTY AS TO QUALITY, FITNESS FOR PURPOSE, OR MERCHANTABILITY IS HEREBY SPECIFICALLY DISCLAIMED AND EXCLUDED BY SELLER. This warranty is void if seller is not notified in writing of any rejection of the goods within ninety (90) days after receipt of the goods by buyer.

Seller shall not be liable under any circumstances for incidental, special or consequential damages arising in whole or in part from any breach by Seller, AND SUCH INCIDENTAL, SPECIAL, OR CONSEQUENTIAL DAMAGES ARE HEREBY EXPRESSLY EXCLUDED.

Our policy is one of continuous development. Specifications shown in this document may be subject to changes introduced after publication.  
 NOTE: The properties, strength, dimensions, installed characteristics and all other information in these materials are for guidance only to aid in the correct selection of the products described herein and is not intended or implied as part of the above warranty. All applications should be evaluated for functional stability and available samples of the described parts can be requested for installed tests, suitability and evaluations.

USATCO U.S. Air Tool Company, Inc.

**Info@usatco.com**

Eastern Division .....60 Fleetwood Ct., Ronkonkoma, NY 11779-6907 tel: (631) 471-3300 fax: (631) 471-3308

Western Division .....1219 W. Mahalo Place, Rancho Dominguez, CA 90220-5446 tel: (310) 632-5400 fax: (310) 632-3900