

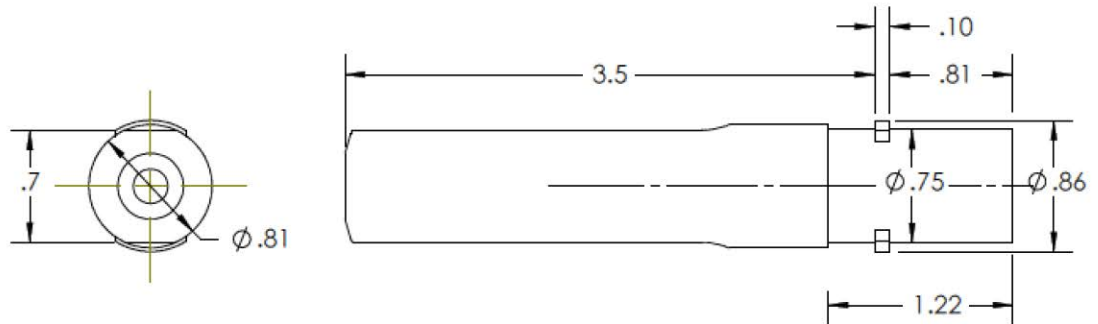

### DIMENSIONAL DATA

See right (all measurements in Inches)



### CHOICE OF RIVETERS

- G83 & G84 Power Riveters
- G84-LS Split Power Riveter (with adaptor 744-700)
- G85D & G87D Riveter (with adaptor 552)

### MOUNTING INSTRUCTIONS

- Attach riveter to air source for correct piston positioning.
- Thread Collet Assembly securely onto the riveter head piston.
- Depress the trigger and attach the sleeve assembly onto the bayonet mount.

### USAGE

- This tool is designed to install 8 diameter Lockbolt fasteners.

### BEFORE USE, MAKE SURE THAT:

- The correct pulling head and nose piece are used and that they are properly mounted on the recommended riveter.
- Proper air source is connected (see riveter specification for recommended pressure).
- Make sure that the tool is clean and in good working condition

### DURING OPERATION

- Inspect the active area of the nose piece regularly.
- Keep the tool clean, especially the nose piece and jaws; pay special attention when sealants are used.
- If stem slippage occurs, the jaws need to be either cleaned or replaced.

### PREVENTATIVE MAINTENANCE

- Clean the nose piece, jaw set and collet every 1,000 installations, or when failures occurs.
- Lubricate outside configuration of the jaw set with Lubriplate® or similar light lubricant.
- Inspect regularly and keep the active area clean and in good working condition.
- Replace worn or broken components.

USATCO U.S. Air Tool Company, Inc.

[Info@usatco.com](mailto:Info@usatco.com)

Eastern Division .....60 Fleetwood Ct., Ronkonkoma, NY 11779-6907 tel: (631) 471-3300 fax: (631) 471-3308

Western Division .....1219 W. Mahalo Place, Rancho Dominguez, CA 90220-5446 tel: (310) 632-5400 fax: (310) 632-3900



**PARTS LIST**

ITEM No.	PART NUMBER	DESCRIPTION	QTY. PER
1	513-151	ANVIL	1
2	513-150	CHUCK COLLET	1
3	513-091	JAW SET	1
4	513-057	O-RING	1
5	513-142	JAW FOLLOWER	1
6	513-061	COMPRESSION SPRING	1
7	513-062	SLEEVE	1
8	513-063	SHIM	2
9	513-086	COLLET ADAPTOR	1

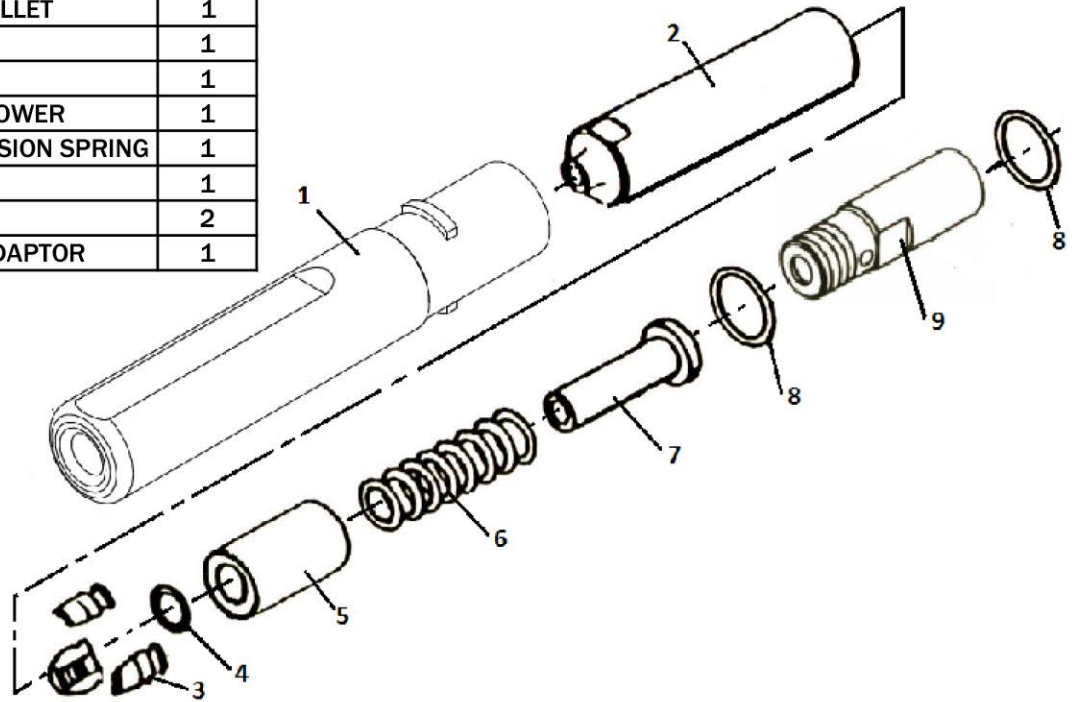

**GENERAL / TECHNICAL QUESTIONS**

1224 E. Warner Avenue  
 Santa Ana, CA 92705 USA  
 1-714-850-6022 (Phone)  
 1-714-850-6093 (Fax)

**WARRANTY**

Seller warrants the goods conform to applicable specifications and drawings and will be manufactured and inspected according to generally accepted practices of companies manufacturing industrial or aerospace fasteners. In the event of any breach of the foregoing warranty, Buyer's sole remedy shall be to return defective goods (after receiving authorization from Seller) for replacement or refund of the purchase price, at the Seller's option. Seller agrees to any freight costs in connection with the return of any defective goods, but any costs relating to removal of the defective or nonconforming goods or installation of replacement goods shall be Buyer's responsibility. SELLER'S WARRANTY DOES NOT APPLY WHEN ANY PHYSICAL OR CHEMICAL CHANGE IN THE FORM OF THE PRODUCT IS MADE BY BUYER. THE FOREGOING EXPRESS WARRANTY AND REMEDY ARE EXCLUSIVE AND ARE IN LIEU OF ALL OTHER WARRANTIES AND REMEDIES; ANY IMPLIED WARRANTY AS TO QUALITY, FITNESS FOR PURPOSE, OR MERCHANTABILITY IS HEREBY SPECIFICALLY DISCLAIMED AND EXCLUDED BY SELLER. This warranty is void if seller is not notified in writing of any rejection of the goods within ninety (90) days after receipt of the goods by buyer.

Seller shall not be liable under any circumstances for incidental, special or consequential damages arising in whole or in part from any breach by Seller, AND SUCH INCIDENTAL, SPECIAL, OR CONSEQUENTIAL DAMAGES ARE HEREBY EXPRESSLY EXCLUDED.

Our policy is one of continuous development. Specifications shown in this document may be subject to changes introduced after publication.

NOTE: The properties, strength, dimensions, installed characteristics and all other information in these materials are for guidance only to aid in the correct selection of the products described herein and is not intended or implied as part of the above warranty. All applications should be evaluated for functional stability and available samples of the described parts can be requested for installed tests, suitability and evaluations.

For more information please contact our Technical Services Department at tel. 714-850-6022

LOCTITE® is a registered trademark of Henkel Corporation.  
 LUBRIPLATE® is a registered trademark of Fiske Brothers Refining Co.

USATCO U.S. Air Tool Company, Inc.

Info@usatco.com

Eastern Division .....60 Fleetwood Ct., Ronkonkoma, NY 11779-6907 tel: (631) 471-3300 fax: (631) 471-3308  
 Western Division .....1219 W. Mahalo Place, Rancho Dominguez, CA 90220-5446 tel: (310) 632-5400 fax: (310) 632-3900