

H513SR-08-48

(1/4" x 4 13/16") Swivel, Self Releasing, Extended Nose Assembly



CHERRY®
AEROSPACE

U.S. Air Tool Company
New York Tel: (631) 471-3300
California Tel: (310) 632-5400
Email: Info@usatco.com

PART NO.	QTY	DESCRIPTION
513-061	1	SPRING, 3/16"
513-062	1	SLEEVE
513-063	1	SHIM
513-068	1	ANVIL RETAINER RING
513-069	1	ANVIL HOLDER
513-071	1	COLLET ADAPTER
513-072	1	SHIM
513-091	1 set	CHUCK JAWS, 1/4" (3 PER SET)
513-093	1	COLLET EJECTOR
513-096	1	ANVIL, 1/4"
513-097	1	ANVIL ASSY 1/4" x 4-13/16"
513-099	1	SPACER
513-101	1	CHUCK COLLET
513-102	1	EJECTOR COLLET ASSY
513-142	1	JAW FOLLOWER

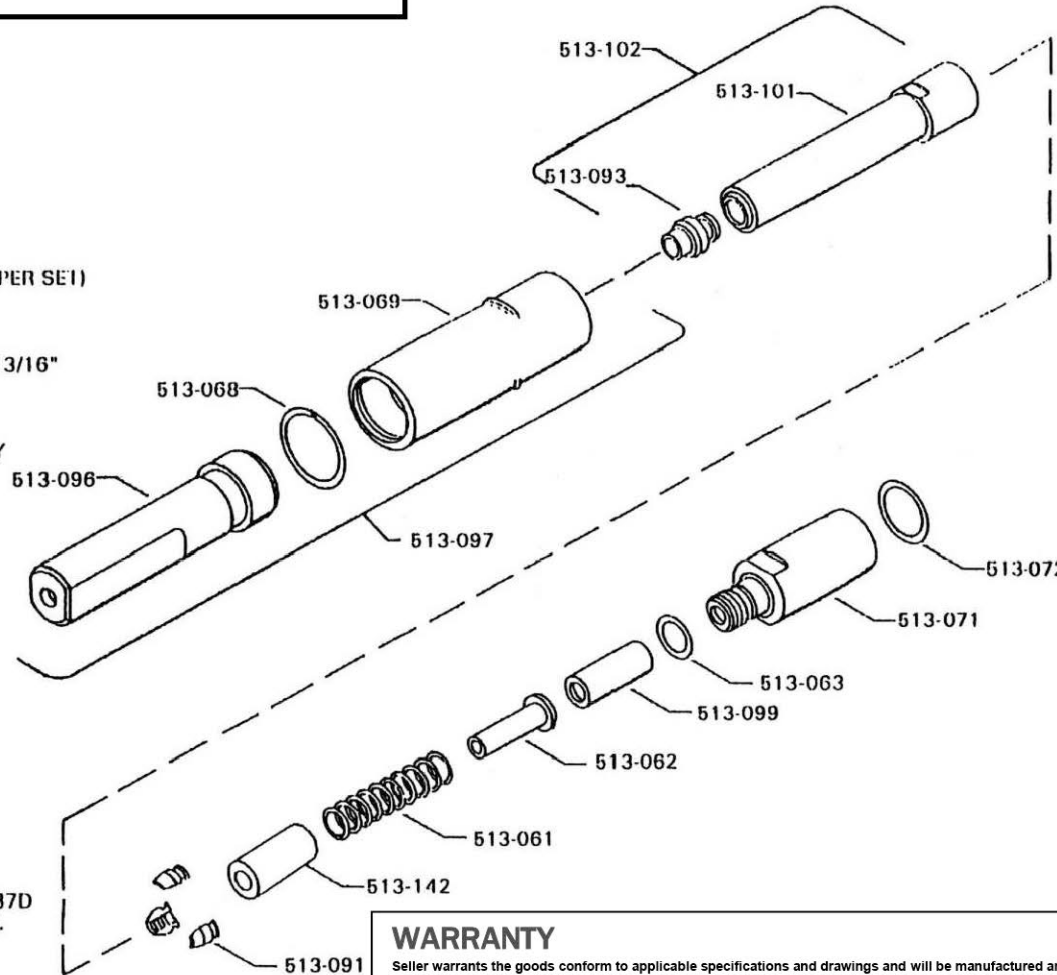

FOR USE ON
CHERRY G85D, G87D
AND HUCK 353.

Loctite® 630-A is a registered trademark of Henkel Corporation
Lubriplate® is a registered trademark of Fiske Brothers Refining Co.

WARRANTY

Seller warrants the goods conform to applicable specifications and drawings and will be manufactured and inspected according to generally accepted practices of companies manufacturing industrial or aerospace fasteners. In the event of any breach of the foregoing warranty, Buyer's sole remedy shall be to return defective goods (after receiving authorization from Seller) for replacement or refund of the purchase price, at the Seller's option. Seller agrees to any freight costs in connection with the return of any defective goods, but any costs relating to removal of the defective or nonconforming goods or installation of replacement goods shall be Buyer's responsibility. SELLER'S WARRANTY DOES NOT APPLY WHEN ANY PHYSICAL OR CHEMICAL CHANGE IN THE FORM OF THE PRODUCT IS MADE BY BUYER. THE FOREGOING EXPRESS WARRANTY AND REMEDY ARE EXCLUSIVE AND ARE IN LIEU OF ALL OTHER WARRANTIES AND REMEDIES; ANY IMPLIED WARRANTY AS TO QUALITY, FITNESS FOR PURPOSE, OR MERCHANTABILITY IS HEREBY SPECIFICALLY DISCLAIMED AND EXCLUDED BY SELLER. This warranty is void if seller is not notified in writing of any rejection of the goods within ninety (90) days after receipt of the goods by buyer. Seller shall not be liable under any circumstances for incidental, special or consequential damages arising in whole or in part from any breach by Seller, AND SUCH INCIDENTAL, SPECIAL, OR CONSEQUENTIAL DAMAGES ARE HEREBY EXPRESSLY EXCLUDED. Our policy is one of continuous development. Specifications shown in this document may be subject to changes introduced after publication. NOTE: The properties, strength, dimensions, installed characteristics and all other information in these materials are for guidance only to aid in the correct selection of the products described herein and is not intended or implied as part of the above warranty. All applications should be evaluated for functional stability and available samples of the described parts can be requested for installed tests, suitability and evaluations.

For more information please contact our Technical Services Department at tel. 714-850-6022