

ORIGINAL INSTRUCTIONS

G84-LS

Split Riveter



Instruction Manual 

Pass on to user to read and keep for reference

MANUAL



CHERRY®
AEROSPACE
SPS Fastener Division, a PCC Company



THE CHERRY® G84-LS SPLIT RIVETER

TABLE OF CONTENTS

Description	2
Technical Specifications	2
Safety Warnings	3
Recommended Usage	3
Reconfiguring for Pistol Grip or In-Line operation	3
Operational Safety Warnings	3
Maintenance and Repair	4
Recommended Fluid	4
Dexron III Oil Safety Data	4
Protecting the High Pressure Hoses	5
Un-wrapping Hoses	5
Fill and Bleed Instructions	5
Replenishing the Hydraulic System with Fluid	5
Bleeding	6
Tool Overhaul	6
Assembly of Double Delta Air Valve Sub-Assembly	6
Head Sub-Assembly	7
Handle Sub-Assembly	7
Tool Care	8
Troubleshooting	8
Parts List	9
Exploded View	10
Cross Section Drawings	11
Declaration of conformity	Back Cover

WARRANTY

Seller warrants the goods conform to applicable specifications and drawings and will be manufactured and inspected according to generally accepted practices of companies manufacturing industrial or aerospace fasteners. In the event of any breach of the foregoing warranty, Buyer's sole remedy shall be to return defective goods (after receiving authorization from Seller) for replacement or refund of the purchase price, at the Seller's option. Seller agrees to any freight costs in connection with the return of any defective goods, but any costs relating to removal of the defective or nonconforming goods or installation of replacement goods shall be Buyer's responsibility. SELLER'S WARRANTY DOES NOT APPLY WHEN ANY PHYSICAL OR CHEMICAL CHANGE IN THE FORM OF THE PRODUCT IS MADE BY BUYER.

THE FOREGOING EXPRESS WARRANTY AND REMEDY ARE EXCLUSIVE AND ARE IN LIEU OF ALL OTHER WARRANTIES AND REMEDIES; ANY IMPLIED WARRANTY AS TO QUALITY, FITNESS FOR PURPOSE, OR MERCHANTABILITY IS HEREBY SPECIFICALLY DISCLAIMED AND EXCLUDED BY SELLER. THIS WARRANTY IS VOID IF SELLER IS NOT NOTIFIED IN WRITING OF ANY REJECTION OF THE GOODS WITHIN ONE (1) YEAR AFTER INITIAL USE BY BUYER OF ANY POWER RIVETER OR NINETY (90) DAYS AFTER INITIAL USE OF ANY OTHER PRODUCT.

Seller shall not be liable under any circumstances for incidental, special or consequential damages arising in whole or in part from any breach by Seller, AND SUCH INCIDENTAL, SPECIAL, OR CONSEQUENTIAL DAMAGES ARE HEREBY EXPRESSLY EXCLUDED.

For more information please contact our Technical Services Department at Tel. 714-850-6022

LOCTITE® is a registered trademark of Henkel Corporation
 DEXRON® is a registered trademark of GM corporation.
 PARKER® is a trademark of Parker Hannifin Corporation
 LUBRRIPLATE® is a trademark of Fiske Brothers Refining Co.

USATCO U.S. Air Tool Company, Inc.

Info@usatco.com

Eastern Division60 Fleetwood Ct., Ronkonkoma, NY 11779-6907 tel: (631) 471-3300 fax: (631) 471-3308
Western Division1219 W. Mahalo Place, Rancho Dominguez, CA 90220-5446 tel: (310) 632-5400 fax: (310) 632-3900

DESCRIPTION

The G84-LS is a powerful, rugged and compact split riveter designed for ergonomic, high speed and reliable operation. Adaptors are available for mounting most Cherry pulling heads; it will install most popular sizes and types of aircraft pull type fasteners including lock-bolts, blind-bolts, etc. This tool may be configured for comfortable left hand, right hand, in-line or pistol-grip operation.

TECHNICAL SPECIFICATIONS

Specifications shown herein are subject to change also Contact us for the latest information available on any

SPECIFICATIONS:

OPERATING AIR PRESSURE 90 to 110 psi (6,2 -7,6 bar)

AIR QUALITY Clean, Filtered

HOSE LENGTH 10 Ft. (3,05 m)

PISTON STROKE 0.530 inch (13,5 mm)

PULLING FORCE 5,700 lbs. @ 110 psi (25,35 kN @ 6,9 bar)

RETURN FORCE 2000 Lbs max. (8,89 kN max @ 6,9 bar)

WEIGHT

HAND HELD UNIT 3.0 lbs. (1,3 kg)

TOTAL 11.8 lbs. (5,3 kg)

NOISE LEVEL 66.5 dB (A)

VIBRATION 4.0 m/s²

AIR CONSUMPTION 0.34 SCF/cycle (9,63 L/cycle)

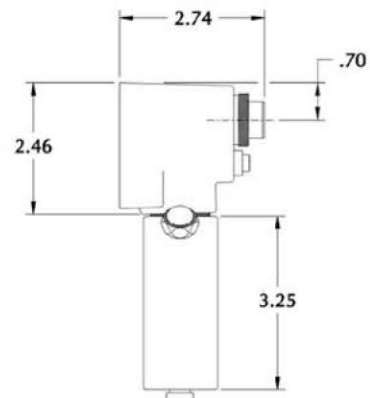
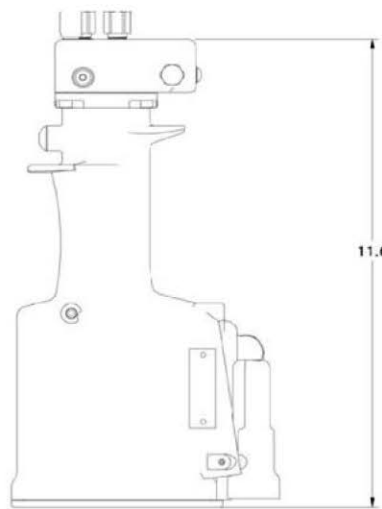

SAFETY WARNINGS

- Do not use beyond the design intent; do not use substitute components for repair.
- Operating this tool with a damaged or missing stem deflector, or using the deflector as a handle, may result in severe personal injury. Rotate the pin deflector facing away from the operator
- Wear proper PPE when operating, repairing, or overhauling this tool ()
- Any modification will void warranty and shall be at the customer's entire responsibility.
- Maintain the tool in a safe working condition at all times and examined at regular intervals for damage.
- Before disassembling the tool for repair, refer to the maintenance instructions. All repairs shall be undertaken only by personnel trained in Cherry installation tools.
- Disconnect the air line from the tool inlet before servicing, adjusting, fitting or removing any accessory.
- Ensure that the vent holes do not become blocked or clogged and the hoses are in good condition.
- Wash thoroughly after handling the fluid; excessive contact could cause rashes.
- Operating air pressure not to exceed 110 psi (7.6 bar); use of a pre-set regulator (P-1505) is recommended
- Do not operate the tool without the pulling head in place.
- All retaining rings, screwed end caps, air fittings, trigger valves and pulling heads should be attached securely and examined at the end of each working shift.
- Do not pull rivet in the air or directed at any person.
- Do not pound on the rear of the tool head to force rivets into holes as this will damage the tool.
- Safety warnings must be explained all operators as part of training.

USATCO U.S. Air Tool Company, Inc.

Info@usatco.com

Eastern Division60 Fleetwood Ct., Ronkonkoma, NY 11779-6907 tel: (631) 471-3300 fax: (631) 471-3308

Western Division1219 W. Mahalo Place, Rancho Dominguez, CA 90220-5446 tel: (310) 632-5400 fax: (310) 632-3900

PUTTING THE TOOL IN SERVICE

The tool must be used with an air pressure regulator. Even if your shop air pressure is below the maximum recommended range, pressure spikes in your airlines could cause serious damage to the tool or cause safety concerns.

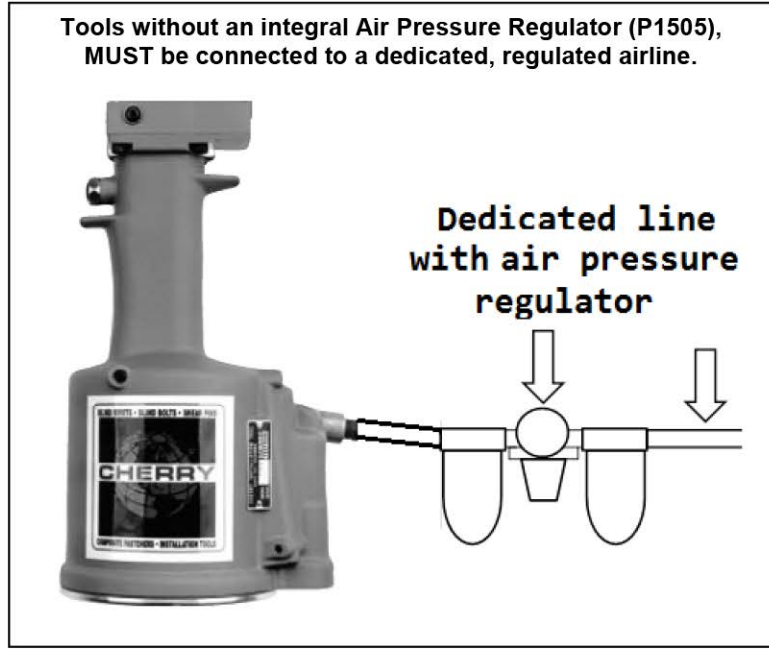

RECOMMENDED USAGE



This Riveter is designed to install pull type fasteners in conjunction with compatible pulling heads. Pulling heads suitable for G84-LSR or comparable riveters will mount directly with no adaptation. Most Cherry® pulling heads may be used with appropriate adaptation (see table). Note: The unit may be used for other applications if it operates within the given parameters, and appropriate safety precautions have been taken. Contact Cherry® Technical Services for more information.

Adapter	To Adapt to Tool Mounting System
744-500	Cherry® G744 mount
744-600	Cherry® G704B/747/746A
744-700	Cherry® G83A/G84 Bayonet
700-800	To adapt to H84B-568

PULLING HEAD INSTALLATION

Connect air source prior to mounting any pulling head; mount per manufacturer instructions.

RIVETER OPERATION

Hold the handle firmly and depress the trigger. Once the operation is completed, release trigger. The tool may be re-configured for Pistol Grip or In-Line; see below for instructions.



Pistol Grip



In-line

RECONFIGURING TOOL GRIP FOR ACCESSIBILITY

Pistol Grip, In-line as well as Left/Right Handed configuration are possible. The standard factory configuration is for pistol grip, right hand operation.

Reconfiguring the tool (refer to Parts List on page 9)::

- Remove the air source and place head cylinder higher than the power unit, over a pan to contain fluid spills.
- Remove some of the hose wrap from under the handle grip (figure 3)
- Slide hand grip (80) away from the head (figure 4).
- Mark which hose goes to "P" and "R" ports and unthread the hose fittings.

For in-line configuration

- Remove plugs the air hose, remove and rotate the Trigger Manifold
- Re-assemble the Trigger Manifold connecting the air hose

For in-line configuration

- Remove the pipe plugs (69) from the back ports;
- Thread the plugs (69) into the vacated holes and tighten them securely.

After reconfiguring the tool

- Thread and tighten the hose fittings in their place making sure to match the P and R ports with the right hoses.
- Bleed per instructions at page 6.



USATCO U.S. Air Tool Company, Inc.

Info@usatco.com

Eastern Division60 Fleetwood Ct., Ronkonkoma, NY 11779-6907 tel: (631) 471-3300 fax: (631) 471-3308
 Western Division1219 W. Mahalo Place, Rancho Dominguez, CA 90220-5446 tel: (310) 632-5400 fax: (310) 632-3900

MAINTENANCE AND REPAIR

Note: Minor fluid loss over time at the piston rod is normal, and does not indicate seal damage.

See troubleshooting guide (page 8) for simple tips on when tool maintenance or repair is necessary.

- Always remove the air source from the tools prior to performing any maintenance work.
- Establish a maintenance schedule according to your production needs to ensure optimum riveter operation
- Inspect routinely for fluid leaks around plugs, screws and fittings, moving parts.

RECOMMENDED FLUID

Automatic transmission fluid, Dexron® III or equivalent. Do not mix different types of fluid, even if they are equivalent.

PROPERTIES: Specific gravity: 0.863

Weight per gallon: 7.18 lbs.

Open flash point: >200°C (392°F)

RECOMMENDED BRAND: ATF Dexron® III. The data herein is for your reference; for the latest MSDS, check with the fluid manufacturer.

DEXRON III® FLUID SAFETY DATA

HANDLING: Eye protection required. Protective gloves, chemical-resistant boots and apron are recommended.
Use in well ventilated area.

FIRST AID

If irritation develops, please consult a physician.

Skin: Wash thoroughly with soap and water as soon as possible. Casual contact requires no immediate attention.

Eyes: Flush with abundant water.

Ingestion: Seek medical attention immediately.
DO NOT INDUCE VOMITING.

Inhalation: Remove from contaminated area; apply artificial respiration if needed. If unconscious, consult physician. No significant adverse health effects expected from short term exposure.

ENVIRONMENT

Storage: Avoid storage near any ignition source, including open flame

Waste Disposal: In accordance with applicable regulations.

Spillage: Prevent entry into drains, sewers and water courses. Soak up with diatomaceous earth or other inert material. Dispose in accordance with applicable regulations.

Combustibility: Slightly combustible if heated above flash point. It will release flammable vapors which can ignite or be explosive in confined spaces if exposed to source of ignition.

Fire: Use suitable extinguishing media: dry powder, foam, and CO2 or water fog. Do not use water jet

HOSE WRAPPING PROCEDURE



Figure 5



Figure 6



Figure 7



Figure 8

TOOLS NEEDED: P1444

PROCEDURE:

- Follow step in figures 5 through 10; hold the installed wrap with one hand, while sliding the tool P1444 over the entire hose length (similar to using a zipper) to complete the operation.
- Wrap tape around the 2 ends of the wrap.



Figure 9



Figure 10

UN-WRAPPING HYDRAULIC HOSES

Figure 11: Unwrap the tape then pull the wrap sideways starting from one end



Figure 11





FILL AND BLEED

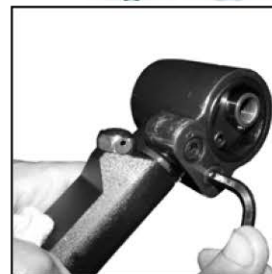

Figure 12

Figure 13

Figure 14

Figure 15

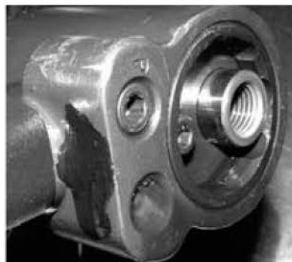

Figure 16

Figure 17

Figure 18

Figure 19

Figure 20

Required tools: Pressurized oil source with correct fitting (#10-32)

A. Replenishing the fluid (refer to page 9 for Component List)

This operation is necessary when a major fluid loss occurred.

- Connect to an air source
- Depress and hold the trigger; disconnect from the air source while holding the trigger depressed.
- Make sure the piston is fully retracted; if not, press it manually.
- Figure 12: Remove the screws (33) from the side and back of manifold (35)
- Figure 13: Thread a pressurized fluid source into the side hole; pump fluid until it flows out smoothly, without any bubbles.
- Figure 14: Thread and tighten the cap screw.
- Figure 15: Remove “R” plug (69) from the head cylinder
- Figure 16: Pump fluid until it flows smoothly, without air bubbles
- Figure 17: Thread in and tighten “R” plug (69) and remove “P” plug (69).
- Figure 18: Place a cloth over the head cylinder to contain the air and fluid that will squirt out of the “R” port
- Figure 19: Connect riveter to an air source and then remove cloth
- Figure 20: Pump fluid until it flows smoothly with no air bubbles
- Thread-in and tighten the “P” plug (69); bleed per instructions given below.

B. Bleeding Instructions (air removal and fluid refill for an already primed tool):

- Required tools: Air Bleeder P/N 700A77.

Procedure:



- Remove screw (33) and attach the air bleeder (700A77)
- Connect riveter to an air source
- Place the handle subassembly (744-189) sideways in a vise, with the head casting (744-202) placed below it; make sure that the air bleeder is up-side down (see picture on the right).
- Push and release trigger several times, observing the fluid inside the Bleeder bottle; repeat until no air bubbles are observed in the bottle during operation



- Disconnect the air bleeder and seal by tightening screw (33)

Caution: Do not depress the trigger before the screw (33) is tightened.

TOOL SERVICE

Tool service is needed in case of tool malfunction, massive fluid loss or as part of your routine maintenance program.

TOOLS NEEDED: G84-LSKT – tool kit, needle-nose pliers,
G84-LSKS – service kit: complete seal and fastener set for tool service

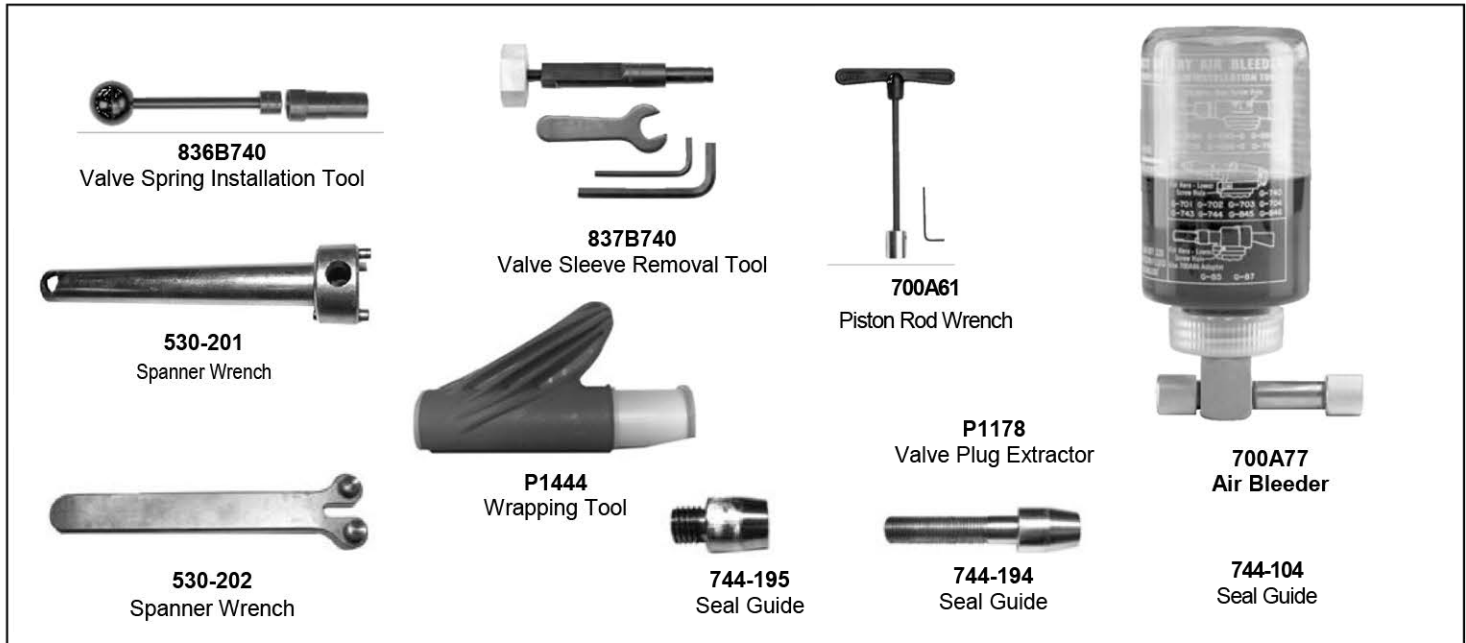

SERVICE PROCEDURE



Caution:

- Maintenance and repair to be conducted only by trained personnel.
- Prior to attempting any repair or maintenance work, make sure the air is disconnected.

Follow these instructions. Use special care handling sealing surfaces.

- Apply an O-ring lubricant (Parker® silicone lube or equivalent) on all O-Rings.
- After service, fill with DEXRON III ATF fluid and bleed (see page 5).

AIR VALVE SUB-ASSEMBLY

Disassembly Instructions:

- Remove retaining ring (56) and muffler (55).
- Insert the valve plug extractor P1178 into the end of valve plug (54) and pull it out.
- Pull out the valve spool subassembly (86) the same way.

Note: In the unlikely event the valve sleeve (47) is irreversibly clogged, remove it as follows:

- Grab one end of spring (49) with needle-nose pliers and turn/pull to dislodge it from its groove
- After spring removal, pull out the valve sleeve (47) by using the removal tool 837B740.

Assembly Instructions: Reverse the above procedures; install valve sleeve (47) carefully with your fingers: gently push and wiggle it to allow O-rings to slip in. Install spring (49); use tool 836B740 to push it firmly into the groove.

USATCO U.S. Air Tool Company, Inc.

Info@usatco.com

Eastern Division60 Fleetwood Ct., Ronkonkoma, NY 11779-6907 tel: (631) 471-3300 fax: (631) 471-3308
Western Division1219 W. Mahalo Place, Rancho Dominguez, CA 90220-5446 tel: (310) 632-5400 fax: (310) 632-3900

HEAD CYLINDER SUB-ASSEMBLY (744-202)**Caution: Remove Pulling Heads or other attachments before attempting to disassemble.****Disassembly instructions:**

- Remove screw (57) and unscrew lock ring (58) with spanner wrench 530-202.
- Drain the fluid over an oil pan; dispose according to environmental regulations.
- Remove rear stop (59) and piston (63) by pressing them out of the rear of the subassembly.
- Remove seals (60, 61, 62, 63, 65, 66, 67 & 68) carefully using a bent hook tool.

Assembly instructions:

- Inspect all components to make sure all surfaces are clean and free of burrs.
- Install O-ring and back-up ring (67 & 68) into groove of head cylinder (70).
- Thread seal guides 744-194 & 744-195 on both sides of the piston (64).
- Mount O-ring and back-up ring (65 & 66) onto the piston (64).
- Carefully push/twist piston (64) into the head cylinder (70) bore, pressing it all the way in.
- Assemble O-ring, backup ring (60 & 61) and O-ring, Back-up ring (62&63) onto rear stop (59) and carefully press it into the head cylinder.
- Thread-in lock ring (58) using spanner wrench 530-202 and secure it with screw (57); use Loctite® 242 on threads. Remove seal guides.

Swivel Assembly Instructions:

- Apply Loctite 545 on the male threads of swivel (75).
- Thread swivel (75) into head cylinder (70) and thread until hand tight.
- Using a 7/16 wrench, tighten threads by rotating one full turn from initial thread seating to secure in place – **Do not over tighten.**
- Allow Loctite to cure for 24 hours for full strength.

HANDLE SUB-ASSEMBLY (744-189)**Disassembly Instructions:** Make sure that the air supply is disconnected before proceeding.

- Unscrew cap screws (19) and remove manifold (35);
- Drain the fluid completely into a pan and dispose according to environmental regulations.
- Remove gasket (22) and O-rings (21)
- Remove retaining ring (1) and the base cover (2) from the bottom of the unit.
- Remove retaining ring (3) and carefully pry handle base (4) from the bottom of the unit, using a screwdriver.
- Engage wrench 700A61 into the hex socket of the piston rod cap (26).
- Remove locknut (6) with a ½ inch (13 mm) socket, while holding with the wrench; unscrew air piston (7) by using wrench 530-201 and a 1 inch (26 mm) socket.
- Pull the air piston (7) out through the bottom of the unit with the help of the tool P1178.
- Remove power piston subassembly (84) through the top of the handle (18) using the guide tool 744-104.
- Remove the packing plug (11) with the help of wrench 530-201 and a 1 ¼ inch (32 mm) Socket.
- Note: To loosen it, hold the handle upside down in a vise, if necessary.
- Remove the O-rings (12 and 13) and back-up rings (14) with a thin, bent hook.
- Place an 1 inch (25,4 mm) rod on top of power cylinder (17) and tap it out carefully through the bottom of the unit with a mallet.

Assembly Instructions: Lubricate O-rings with Parker® silicone O-ring lube or equivalent and handle all seals with care.

- Make sure the gaskets and seals are in good condition and are placed correctly.
- Insert the power cylinder (17) with O-rings (15 & 16) into the handle (18) bore through the bottom of handle. To properly seat it, place an 1 inch (26 mm) bar against its bottom surface, and carefully tap into place with a mallet.
- Insert O-rings (13) and back-up rings (14) in packing plug (11).
- Thread packing plug in tightly against the power cylinder (17) using wrench 530-201 and a 1 ¼ inch (32 mm) socket.
- Thread seal guide tool 744-104 into the end of the power piston (25) then push into the bore of the power cylinder (17) through the top of handle (18). Tap it through the packing plug (11) with a mallet; remove the seal guide.
- Using wrench 530-201 insert air piston (7) with quad ring (9) and back-up rings (8) into the main bore of the handle (18) until it engages the threaded end of the power piston (25); tighten them together wrench 700A61.
- Thread and tighten locknut (6) onto power piston (25) with a ½" socket (13 mm) at 50 to 59 in-lbs (5,65 to 6,67 N-m).
- Insert handle base (4) with lubricated O-ring (5) into the bottom of the handle (18) and tap it into its seat.
- Place retaining ring (3), base cover (2), and retaining ring (1).
- Push the piston downwards with the help of wrench 700A61.
- Fill the handle subassembly with fluid to about 1/8 inch (3 mm) above the top of the power piston (17).
- Place new gasket & O-rings (21,22) on top of handle (18); mount the manifold (35) tightening screws (19) evenly.

USATCO U.S. Air Tool Company, Inc.

Info@usatco.com

Eastern Division60 Fleetwood Ct., Ronkonkoma, NY 11779-6907 tel: (631) 471-3300 fax: (631) 471-3308

Western Division1219 W. Mahalo Place, Rancho Dominguez, CA 90220-5446 tel: (310) 632-5400 fax: (310) 632-3900

TOOL CARE

This tool has been designed for optimum service with minimum care.

In order to extend the life of the tool, please follow the simple instructions given below:

- Make sure the system is filled properly with fluid and is free of air (see fill and bleed instructions)
- Use only regulated, clean air; dirt and moisture will cause damage to the pneumatic system.
- Inspect for air and fluid leaks routinely. Minor fluid loss over time is normal, but increased fluid or air loss indicates seal damage. Make sure that all fittings are properly tightened and secured.
- Do not operate with hoses unprotected or with a damaged hose wrap.
- Perform regular service and maintenance.

TROUBLESHOOTING GUIDE

PROBLEM	POSSIBLE REASONS / SOLUTIONS
Piston does not move after depressing Trigger	- No air supply is connected: Connect to a clean, filtered air source at 90 to 110 psi (6,2 to 7,6 bar).
	- Faulty trigger: Remove and replace trigger assembly.
	- Broken power piston: Service the Handle Subassembly per page 7.
Short stroke or low pull force	- Significant fluid loss: Bleed the system per page 5. If performance doesn't improve, or excessive leakage continues, see below.
Head Cylinder Fluid leakage	- Leaks around the plugs (69) or fittings indicate that they are not tightened to seal properly: Tighten until no more leaks are observed.
	- Leaks at the front or back of head cylinder (70) indicate worn or damaged seals:
	Service head cylinder per page 7.
Air leakage at the valve	- Broken or dislodged spring (49).
	- Worn or damaged valve spool seals: Disassemble and service air valve per Air Sub-Assembly Overhaul Instructions.
Head piston (64) is slow or seizes	- Piston or seal damage: Service head cylinder per page 7.
	- Oil bypassing due to power piston (25) displacement Of its seat in subassembly (84): Service Handle Subassembly per page 7.
	- Clogged muffler (55) or air filter (51): Clean thoroughly with solvent and back-blow with compressed air.
	- Lock ring (item 58) is not secured due to loose cap screw (57): Tighten lock-ring, and then secure it by tightening cap screw. Use Loctite® removable thread locker to secure it.
Head Piston (64) does not return fully forward even after system bleeding	- Pressure relief valve (85) malfunction: Remove valve then O-ring (42) from the manifold (35). Clean and dry thoroughly components. Replace O-Ring (use Parker® silicone O-ring lube or equivalent). Re-assemble valve; make sure the O-ring (42) is seated concentrically inside of the valve cavity before installing the Ball-seat (41) into the manifold (35).
	- Compression spring (31) is damaged or broken: Remove handle manifold (35) and replace the damaged spring. Re-assemble, fill and bleed per page 5.

Cherry® is well known for the quality of our tools and our outstanding customer support.

If the tool does not perform at the expected performance please contact our representatives.

LOCTITE® is a registered trademark of Henkel Corporation

DEXRON® is a registered trademark of GM Corporation.

PARKER® is a trademark of Parker Hannifin Corporation

G84-LS CROSS SECTIONAL VIEW

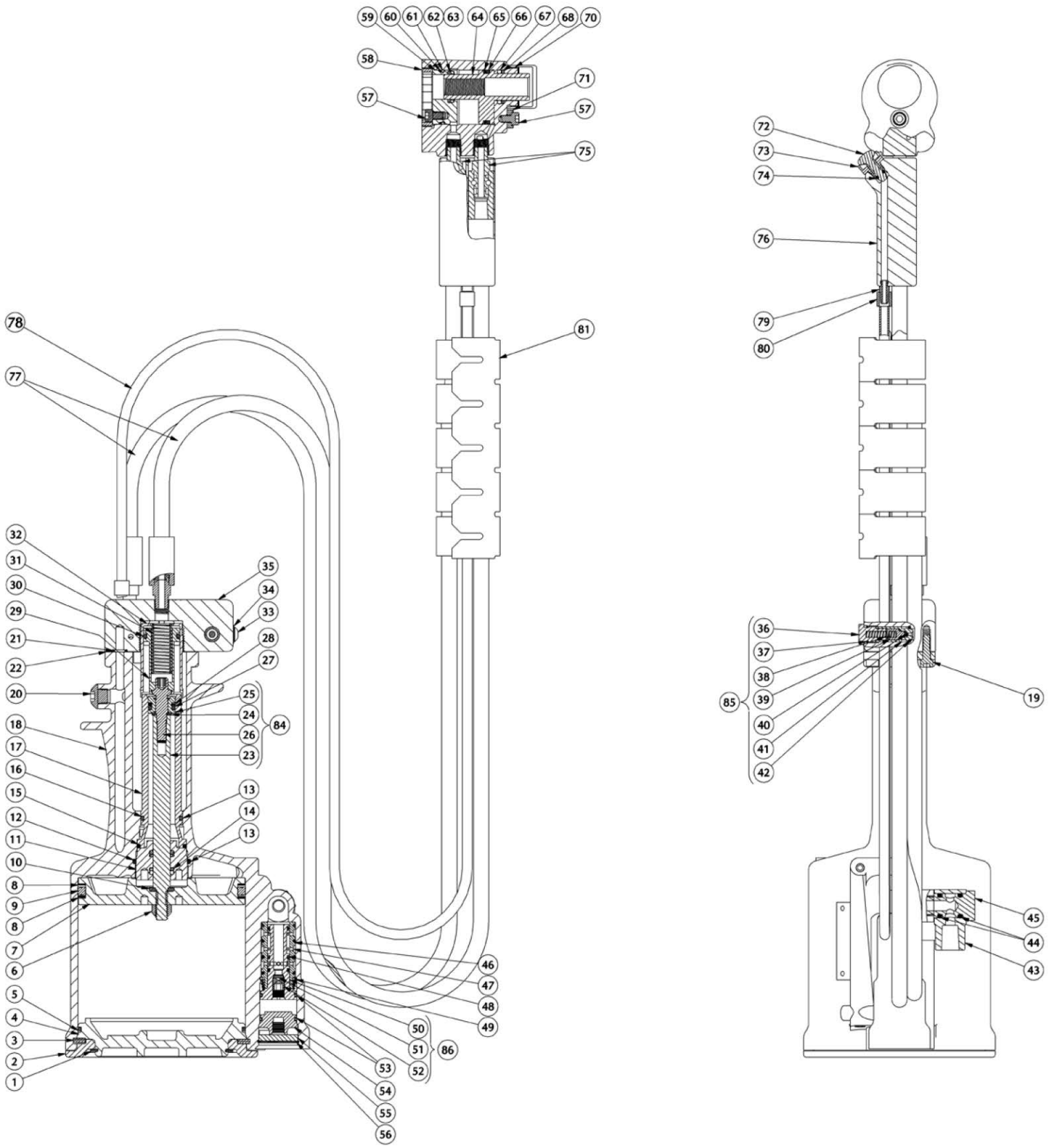

PART LIST FOR THE G84-LS SPLIT RIVETER (744-190)

ITEM NO.	PART NO	DESCRIPTION	QTY
744-189 Sub-Assembly, Handle			1
1	P884	Ring, Retaining	1
2	740B5	Cover, Base	1
3	P886	Ring, Retaining	1
4	740C4	Base, Handle	1
5	P890	O-Ring	1
6	P1392	Nut, Conelok	1
7	744-094	Piston, Air	1
8	P909	Ring, Back-Up	2
9	P887	Ring, Quad	1
10	744-095	Washer, Air Piston	1
11	744-165	Plug, Packing	1
12	P889	O-Ring	1
13	P1405**	O-Ring	2
14	P1410	Ring, Back-Up	2
15	P892**	O-Ring	1
16	P833**	O-Ring	1
17	744-161	Cylinder, Power	1
18	743A11	Handle	1
19	P73	Cap Screw, Soc. Head	4
20	530A113	Cap Screw, Button Head.	1
21	P832**	O-Ring	2
22	744-171	Gasket, Manifold	1
84	744-122	Sub-Assembly, Power Piston And Rod	1
	23	744-164* Rod, Power Piston	1
	24	740A12* Stop, Piston	1
	25	744-163* Piston, Power	1
	26	744-087* Cap, Piston Rod	1
27	P1406	O-Ring	1
28	P213	Ring, Back-Up	1
29	744-160	Piston, Return	1
30	P104	O-Ring	1
31	P1414	Spring, Compression	1
32	744-175	Cylinder, Return	1
33	P573	Screw, Button Hd. Cap	2
34	P572	Stat-O-Seal	2
35	744-188	Manifold, Handle	1*
85	700-214	Sub-Assembly, Relief Valve	1
	36	700-218 Seat, Spring	1
	37	P383 O-Ring	1
	38	P1366 Spring	1
	39	700-217 Piston, Valve	1
	40	P688 Ball	1
	41	700-215 Seat, Ball	1
	42	P111 O-Ring	1
43	530A34	Swivel	1
44	P195	O-Ring	2
45	530A35	Swivel Bolt	1

ITEM NO.	PART NO.	DESCRIPTION	QTY
	46	P268 O-Ring	4
	47	740B14 Sleeve, Valve	1
	48	P891** O-Ring	3
	49	740A18 Spring	1
	86	740A15 Sub-Assembly, Valve Spool	1
	50	740B15-1* Spool, Valve	1
	51	700A18* Filter	1
	52	700A69* Screw, Metering	1
	53	P848 O-Ring	2
	54	740B16 Plug, Valve	1
	55	740A17 Muffler	1
	56	P321 Ring, Retaining	1
744-202 Sub-Assembly, Head Cylinder			1
	57	P85 Screw, Soc. Hd. Cap	2
	58	744-144 Lock, Ring, Power	1
	59	744-142 Stop, Rear	1
	60	P1419 Ring, Back-Up	1
	61	P1420 O-Ring	1
	62	P1411 Ring, Back-up	1
	63	P1407 O-Ring	1
	64	744-140 Piston, Head	1
	65	P1412 Ring, Back-up	1
	66	P1409** O-Ring	1
	67	P1408** O-Ring	1
	68	P209** Ring, Back-up	1
	69	P698 Pipe plug, Level Seal	2
	70	744-168 Cylinder, Head	1
	71	744-145 Stop, Pulling Head	1
703A33 Sub-Assembly, Trigger			1
	72	530A38 Trigger	1
	73	703A32 Sleeve, Trigger	1
	74	P223 O-Ring	1
75	744-150	Swivel, High Pressure	2
76	744-185	Trigger, Manifold	1
77	P1415	Assembly, High Pressure Hose	2
78	744-186	Air Tubing	1
79	P1453	Barbed Air Fitting	2
80	P1452	Tubing Clamp	2
81	744-193	Cable Wrap	1
82	744-503***	Fitting, Pin Deflector (sold separately)	1
83	530A16***	Pin Deflector (sold separately)	1

* Only within subassembly; component not sold separately.
 ** No Substitutions
 *** Not provided in standard configuration - to be purchased as needed.

**G84-LS
EXPLODED
VIEW**

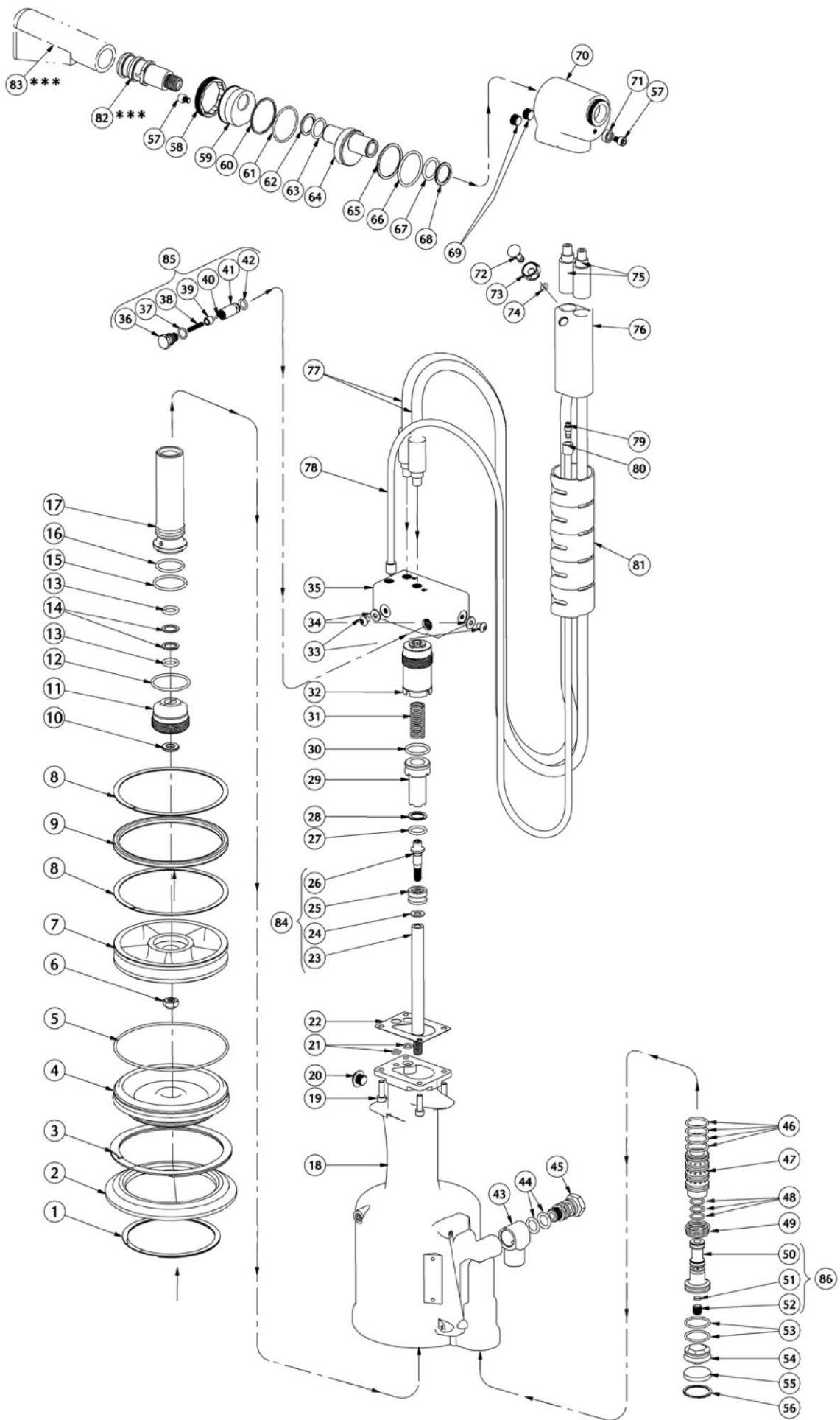



CHERRY® **AEROSPACE**
 SPS Fastener Division, a PCC Company



Declaration of Conformity

We, *Cherry Aerospace*

Located at 1224 East Warner Avenue, Santa Ana, CA 92705-0157, USA,

In accordance with the provisions of

Machine Directive 2006/42/EC

Hereby declare under our sole responsibility that:

Equipment: Pneumatic Hydraulic Hand Riveter

Model Number: G84-LS

Serial Number: _____

Is in conformity with the applicable requirements of the following standards:

- | | |
|-------------------------|---|
| EN ISO 12100:2010 | Safety of Machinery; General Principles; Risk Assessment and Reduction |
| ISO/TR 14121-1&2:2007 | Safety of Machinery, Risk assessment |
| EN 792-1:2000 + A1:2008 | Safety requirements; Assembly power tools for non-threaded mechanical fasteners |
| ISO 8662-11 | Hand-held portable power tools -- Measurement of vibrations at the handle |
| ISO 3744 | Acoustics – Determination of sound power levels of noise sources |
| ISO 4413:2010. | Hydraulic fluid power - General Rules of safety |
| ISO 4414:2010. | Pneumatic fluid power - General Rules of safety |

Signed by:

Cris Cobzaru,

Master of Science in Mechanical Engineering

Sr. Technical Services / Installation Tooling Engineer

The Technical documentation for the machinery is available from:

Name: Karl-Heinz Beckers

Position: CE Representative and Western Europe Sales Manager

Address: Maternusstrasse 14, D-52538, Gangelt, Germany

Mobile Phone +49 -(0) 171 31 88020