

H744MB

Straight Pulling Head

INSTRUCTION SHEET, Page 1 of 2



CHERRY[®]
AEROSPACE

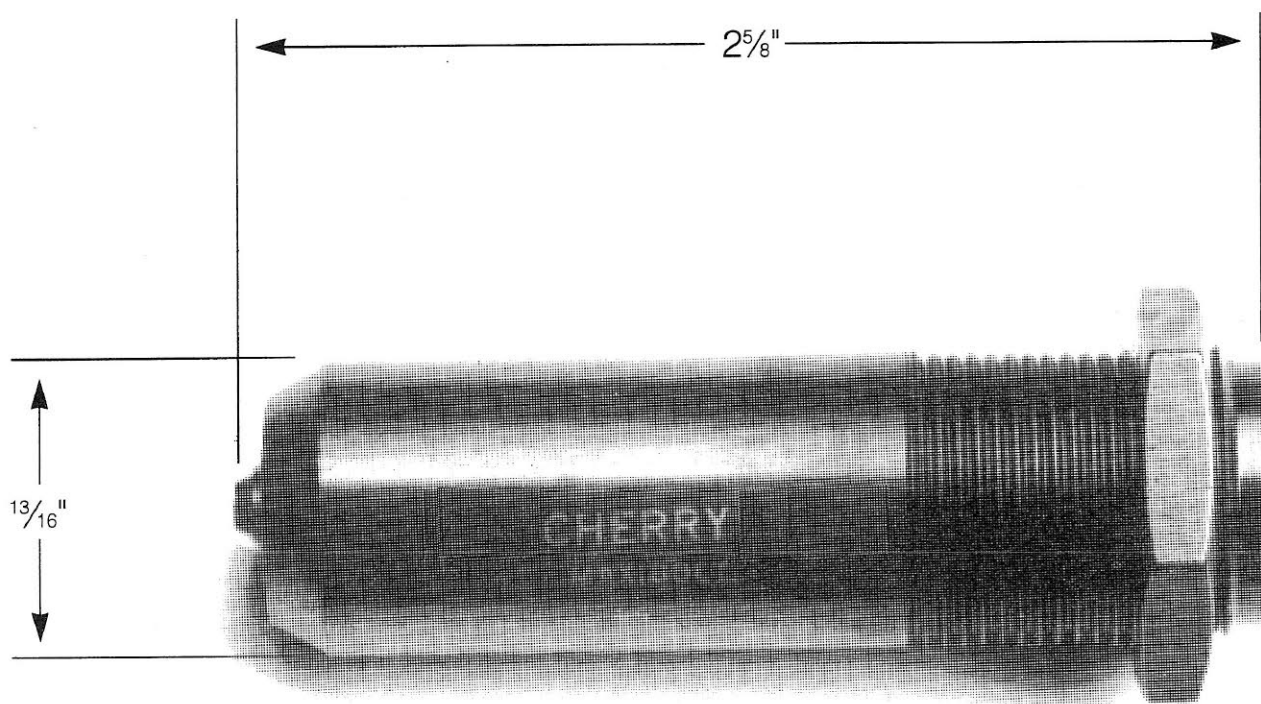

STEM THROUGH FEED

The H744MB series pulling heads fit directly on the G744 riveter. The heads in this series are capable of installing 5/32 and 3/16 diameter "S" type Alloy Steel and A-286 Stainless Maxibolts[®] in all grip lengths.

Using a 560-070 adapter, the H744MB pulling head can be attached to the G85D and G87D riveters.

This head is designed to install the "S" type Cherry Maxibolt. Because of different requirements of the "S" and "U" type blind bolts, it will be necessary to replace the nose piece on this head to install "U" type blind bolts. This will insure proper seating of the lock collar.

Nose piece is replaceable. Use an arbor press and brass punch to remove the old nose piece. Install new nose piece by carefully pressing it into the sleeve.

USATCO U.S. Air Tool Company, Inc.

Info@usatco.com

Eastern Division60 Fleetwood Ct., Ronkonkoma, NY 11779-6907 tel: (631) 471-3300 fax: (631) 471-3308

Western Division1219 W. Mahalo Place, Rancho Dominguez, CA 90220-5446 tel: (310) 632-5400 fax: (310) 632-3900

H744MB

Straight Pulling Head

INSTRUCTION SHEET, Page 2 of 2



CHERRY®
AEROSPACE

Parts List

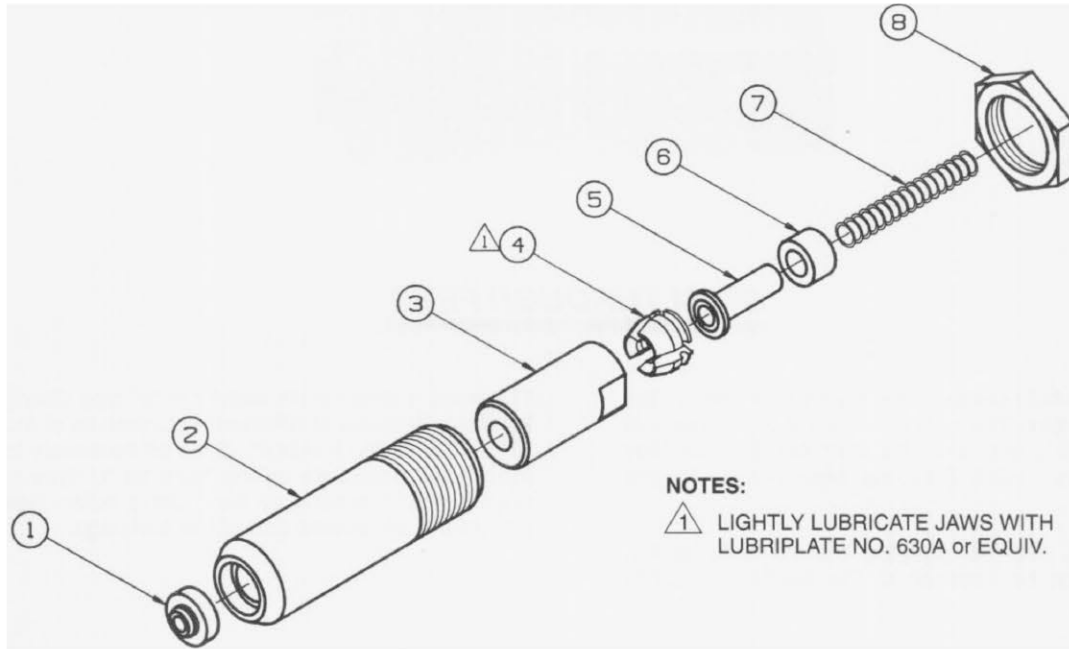

NOTES:

△ 1 LIGHTLY LUBRICATE JAWS WITH LUBRIPLATE NO. 630A or EQUIV.

PULLING HEAD ASSEMBLY NO.	1 NOSEPIECE	2 SLEEVE	3 COLLET	4 JAWS (3 PCS)	5 JAW FOLLOWER	6 CUSHION	7 JAW SPRING	8 JAM NUT
H744-5MB	744B65-5	744B51	744B52	744C75	744A53	744A54	P-964	642A64
H744-6MB	744B65-6			744C76				

Use 530-203-5 for 5/32" "U" type blind bolts / 530-203-6 for 3/16" "U" type blind bolts

LUBRIPLATE® is a registered trademark of Fiske Brothers Refining Co

WARRANTY

Seller warrants the goods conform to applicable specifications and drawings and will be manufactured and inspected according to generally accepted practices of companies manufacturing industrial or aerospace fasteners. In the event of any breach of the foregoing warranty, Buyer's sole remedy shall be to return defective goods (after receiving authorization from Seller) for replacement or refund of the purchase price, at the Seller's option. Seller agrees to any freight costs in connection with the return of any defective goods, but any costs relating to removal of the defective or nonconforming goods or installation of replacement goods shall be Buyer's responsibility. SELLER'S WARRANTY DOES NOT APPLY WHEN ANY PHYSICAL OR CHEMICAL CHANGE IN THE FORM OF THE PRODUCT IS MADE BY BUYER. THE FOREGOING EXPRESS WARRANTY AND REMEDY ARE EXCLUSIVE AND ARE IN LIEU OF ALL OTHER WARRANTIES AND REMEDIES; ANY IMPLIED WARRANTY AS TO QUALITY, FITNESS FOR PURPOSE, OR MERCHANTABILITY IS HEREBY SPECIFICALLY DISCLAIMED AND EXCLUDED BY SELLER. This warranty is void if seller is not notified in writing of any rejection of the goods within ninety (90) days after receipt of the goods by buyer.

Seller shall not be liable under any circumstances for incidental, special or consequential damages arising in whole or in part from any breach by Seller, AND SUCH INCIDENTAL, SPECIAL, OR CONSEQUENTIAL DAMAGES ARE HEREBY EXPRESSLY EXCLUDED.

Our policy is one of continuous development. Specifications shown in this document may be subject to changes introduced after publication.

NOTE: The properties, strength, dimensions, installed characteristics and all other information in these materials are for guidance only to aid in the correct selection of the products described herein and is not intended or implied as part of the above warranty. All applications should be evaluated for functional stability and available samples of the described parts can be requested for installed tests, suitability and evaluations.

For more information please contact our Technical Services Department at tel. 714-850-6022

USATCO U.S. Air Tool Company, Inc.

Info@usatco.com

Eastern Division60 Fleetwood Ct., Ronkonkoma, NY 11779-6907 tel: (631) 471-3300 fax: (631) 471-3308

Western Division1219 W. Mahalo Place, Rancho Dominguez, CA 90220-5446 tel: (310) 632-5400 fax: (310) 632-3900