

H955-(*)

CherryLock "A" code Pulling Heads



CHERRY[®]
AEROSPACE

TECHNICAL DATA SHEET, Page 1 of 2

Choice of Riveters

- G747 CHERRY[®] Riveters
- G704B CHERRY[®] Riveters
- G746A CHERRY[®] Riveters

MOUNTING INSTRUCTIONS (see parts list)

- Attach Riveter to air source for correct piston positioning.
- Insert the spring into the riveter's head piston.
- Place the jaws inside the collet.
- Place the bumper over the jaw follower and place this assembly into the collet against jaws.
- Tighten securely, using a wrench.
- Thread sleeve snugly into end of head cylinder; tighten securely with the jam nut.
- Cycle the tool to make sure it is functional.

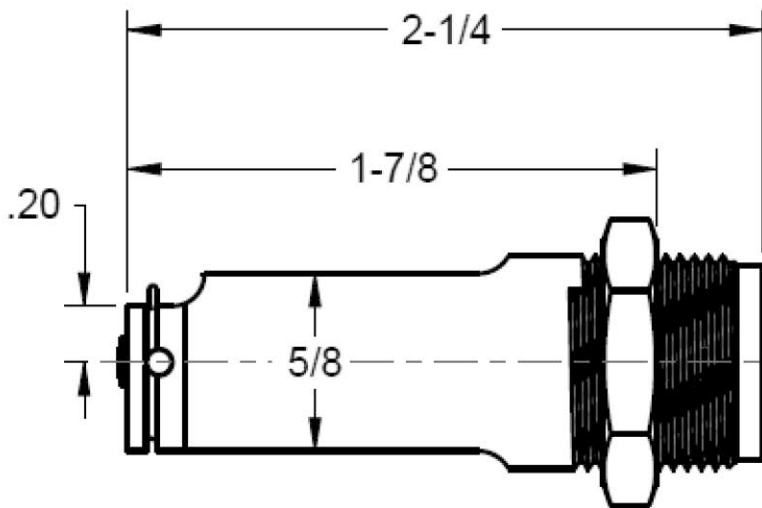

BEFORE USE, CHECK IF:

- The Pulling Head is correctly mounted and the proper riveter is selected.
- Proper Air source is connected (see Riveter specification for recommended pressure).
- The appropriate Nose Piece is used and the tool is clean and in good working condition.

USAGE

- This tool was designed to install A code type Cherrylock blind fasteners; order the right part number for the fastener diameter to install (-3, -4, -5 or -6 diameter, see table on next page).
- Due to limitations in riveter power and stroke, some grip lengths may need double triggering the riveter and the longer grips may need a different riveter to install. Please refer to the individual tool specification for capacity.

DURING OPERATION

- Inspect the front active area of the Nosepiece regularly; replace when worn.
- Keep the tool clean, especially the Nosepiece and Jaws; pay special attention when used with sealants and adhesives.
- If stem slippage occurs, clean or replace the internal jaws.

USATCO U.S. Air Tool Company, Inc.

Info@usatco.com

Eastern Division60 Fleetwood Ct., Ronkonkoma, NY 11779-6907 tel: (631) 471-3300 fax: (631) 471-3308
Western Division1219 W. Mahalo Place, Rancho Dominguez, CA 90220-5446 tel: (310) 632-5400 fax: (310) 632-3900

H955-(*)

CherryLock "A" code Pulling Heads



CHERRY®
AEROSPACE

TECHNICAL DATA SHEET, Page 2 of 2

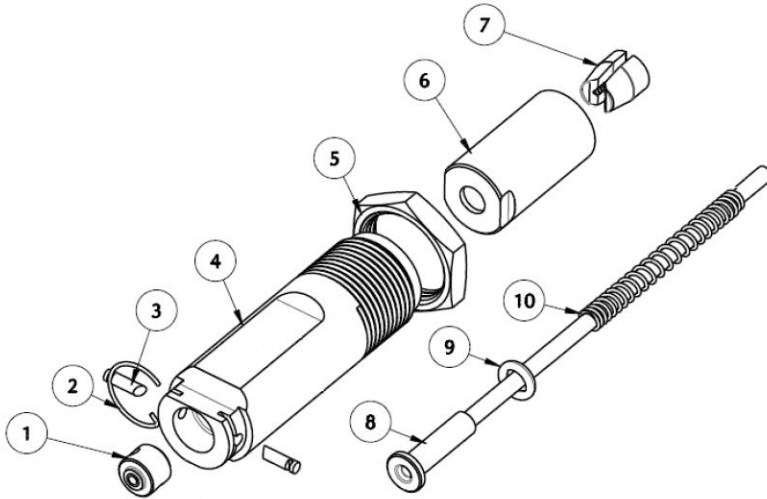

PARTS LIST & PREVENTATIVE MAINTENANCE

- Inspect active area regularly and keep it clean, in good condition
- Clean the Insert, Jaws and Jaw Cavity inside the Collet every 1,000 installations.
- Lubricate outside configuration of the jaws with Lubriplate® or similar light grease.

ITEM	PULLING HEAD P/N	H955-3	H955-4	H955-5	H955-6	QTY
	DESCRIPTION	COMPONENT PART NUMBER				
1	NOSEPIECE INSERT	960-023	960-024	960-025	960-026	1
2	STEM STOP SPRING	711A9	711A9	711A9	711A9	1
3	STEM STOP	712A10-1	712A10-2	712A10-4	712A10-5	2
4	SLEEVE	955-017	955-017	955-017	955-017	1
5	JAM NUT	671A16	671A16	671A16	671A16	1
6	COLLET	955-015	955-015	955-015	955-015	1
7	JAW SET	711B6-3	711B6-4	711B6-5	711B6-6	1
8	JAW FOLLOWER	955-011	955-016	955-016	955-016	1
9	O-RING	P-293	P-293	P-293	P-293	1
10	SPRING	P-1271	P-1271	P-1271	P-1271	1

LOCTITE® is a registered trademark of Henkel Corporation.
LUBRIPLATE® is a registered trademark of Fiske Brothers Refining Co.

WARRANTY

Seller warrants the goods conform to applicable specifications and drawings and will be manufactured and inspected according to generally accepted practices of companies manufacturing industrial or aerospace fasteners. In the event of any breach of the foregoing warranty, Buyer's sole remedy shall be to return defective goods (after receiving authorization from Seller) for replacement or refund of the purchase price, at the Seller's option. Seller agrees to any freight costs in connection with the return of any defective goods, but any costs relating to removal of the defective or nonconforming goods or installation of replacement goods shall be Buyer's responsibility. SELLER'S WARRANTY DOES NOT APPLY WHEN ANY PHYSICAL OR CHEMICAL CHANGE IN THE FORM OF THE PRODUCT IS MADE BY BUYER. THE FOREGOING EXPRESS WARRANTY AND REMEDY ARE EXCLUSIVE AND ARE IN LIEU OF ALL OTHER WARRANTIES AND REMEDIES; ANY IMPLIED WARRANTY AS TO QUALITY, FITNESS FOR PURPOSE, OR MERCHANTABILITY IS HEREBY SPECIFICALLY DISCLAIMED AND EXCLUDED BY SELLER. This warranty is void if seller is not notified in writing of any rejection of the goods within ninety (90) days after receipt of the goods by buyer.

Seller shall not be liable under any circumstances for incidental, special or consequential damages arising in whole or in part from any breach by Seller, AND SUCH INCIDENTAL, SPECIAL, OR CONSEQUENTIAL DAMAGES ARE HEREBY EXPRESSLY EXCLUDED.

Our policy is one of continuous development. Specifications shown in this document may be subject to changes introduced after publication.

NOTE: The properties, strength, dimensions, installed characteristics and all other information in these materials are for guidance only to aid in the correct selection of the products described herein and is not intended or implied as part of the above warranty. All applications should be evaluated for functional stability and available samples of the described parts can be requested for installed tests, suitability and evaluations.

For more information please contact our Technical Services Department at tel. 714-850-6022

USATCO U.S. Air Tool Company, Inc.

Info@usatco.com

Eastern Division60 Fleetwood Ct., Ronkonkoma, NY 11779-6907 tel: (631) 471-3300 fax: (631) 471-3308

Western Division1219 W. Mahalo Place, Rancho Dominguez, CA 90220-5446 tel: (310) 632-5400 fax: (310) 632-3900