



Toll Free US & Canada: **800-645-8180**

**Eastern Division**

60 Fleetwood Ct., Ronkonkoma, NY 11779-6907  
Telephone: (631) 471-3300 Fax: (631) 471-3308

**Western Division**

1219 W. Mahalo Place, Rancho Dominguez, CA 90220-5446  
Telephone : (310) 632-5400 Fax: (310) 632-3900

*Supplying the Aerospace, Defense & Metal Working Industries Since 1951!*

**Minimum Order**

\$100.00 List Price

**Terms**

Net 30 days on approved credit only.  
Approved credit cards.  
Prepaid via check or wire transfer.

**No C.O.D. shipments.**

**Returns**

Return authorization is required.  
Merchandise must be sent freight prepaid to the facility from which it was purchased.  
A 20% restocking charge is applicable.

**All claims must be made within 7 days of receipt of goods.**

**Freight**

F.O.B. shipping point.

**Special Orders**

All special orders may require prepayment.

**Currency**

All prices are in US dollars.

**Overseas Customer Terms**

Same as above, only **prepayment via bank wire transfer (all fees for buyers account) or by bank check.**

US Air Tool Company (also known as USATCO) has been a family owned and operated business since 1951. We are now a US manufacturer and worldwide distributor of high quality tools for the aviation industry with offices in New York & California. In addition, from the beginning of the homebuilder era in the 1970's, USATCO has been providing tools and equipment to craftsmen around the world who build and fly their own aircraft. These "sheet-metal artists" are now flying thousands of planes built and maintained with USATCO tools.

USATCO offers the highest quality products at competitive prices, with the knowledge and experience necessary for expert advice in product selection. Our courteous staff will be pleased to assist you. And of course, all the products we offer are fully guaranteed. If you don't see what you are looking for, please don't hesitate to contact us. We work hard to provide our customers with straightforward & reliable business. Try us & see!

**USATCO.com**

Don't forget to check out USATCO Online, with monthly sales, homebuilder specials, surplus items & an easy to use interface its a great place to shop for tools on the web. **www.USATCO.com**

**Government IMPAC Cards Accepted**

**USATCO Tool Repair**

We repair all major brand pneumatic tools on our premises. We are an official repair station for Cherry Textron<sup>®</sup>, Chicago Pneumatic<sup>®</sup>, and Cooper<sup>®</sup> Power Tools (including Dotco<sup>®</sup>, Gardener Denver<sup>®</sup>, Buckeye<sup>®</sup> and Doler<sup>®</sup>). In addition, we have our own manufacturing and modification facilities. We are riveting and product assembly specialists!

We will be happy to examine your tools free of charge and give you an estimate of repair cost. Ship prepaid to any of our facilities. Please send tensiometers to our New York Lab only.

**Please ask about our tool rental policy!**

**Limited Warranty**

*If for any reason you are not completely satisfied with any item purchased from us you may request a return authorization within seven (7) days of receipt of goods. When obtained, send us the item (transportation prepaid) for replacement, repair or refund. Tools manufactured by USATCO are warrantied for one (1) year from date of purchase. We cannot assume liability for abuse, misuse or alteration of goods. Any tampering with tools or attempted repairs of same will nullify this warranty. Warranties from other manufacturers available upon request.*

## MATERIAL REMOVAL TOOLS

### USATCO Rivet Shaver Kit



**Includes:**

1900RS Rivet Shaver, Seven Cutters (5/16", 3/8", 7/16", 1/2", 9/16", 5/8" & 3/4"), Seven Skirts (5/16", 3/8", 7/16", 1/2", 9/16", 5/8" & 3/4"), Removable Cutter Box & Foam Fitted Case

Part Number	Description
53-1900RS	Complete 17 PC Kit

### ATI® Pro Rivet Shaver Kit

*Other Configurations Available, Please Inquire*



**Includes:**

SRS10P21-8 Rivet Shaver, Seven Cutters (5/16", 3/8", 7/16", 1/2", 9/16", 5/8" & 3/4"), Seven Skirts (5/16", 3/8", 7/16", 1/2", 9/16", 5/8" & 3/4") & Sturdy Fitted Toolbox

Part Number	Description
53-1900RSK	Complete 16 PC Kit

### Dotco® Rivet Shavers



- Ergonomic design, rear exhaust.
- Easily adjustable positive lock.
- Spring loaded nosepiece & stabilizer.

\* Model 14CFS60-98 does not include stabilizer.

Small Handle Pistol Grip 0.4 hp (0.30 kW) - 29,000 RPM			
Part Number	Cutter Adj.	Overall Length	Weight
14CFS60-95	0.0005"	8-1/4" (210 mm)	2.3 lbs (1.0 kgs)

Small Handle Pistol Grip 0.4 hp (0.30 kW) - 29,000 RPM			
Part Number	Cutter Adj.	Overall Length	Weight
14CFS60-98*	0.00025"	8-1/4" (210 mm)	2.3 lbs (1.0 kgs)

Large Handle Pistol Grip 0.9 hp (0.67 kW) - 20,000 RPM			
Part Number	Cutter Adj.	Overall Length	Weight
14CNL60-95	0.0005"	8-7/8" (226 mm)	4.5 lbs (2.0 kgs)

### Sioux® Rivet Shavers



- Spring loaded removable stabilizer.
- Ergonomic handle for comfortable use.

**Note:** Available with other skirt sizes, please inquire.

Pistol Grip 1.0 hp (0.75 kW) - 21,000 RPM			
Part Number	Capacity	O.A.	Weight
SRS10P21-8	1/2"	8" (205 mm)	2.7 lbs (1.2 kgs)

Lever Grip 1.0 hp (0.75 kW) - 21,000 RPM			
Part Number	Capacity	Overall Length	Weight
SRS10S21-8	1/2"	10" (255 mm)	2.5 lbs (1.1 kgs)

**Dotco® Quad Weld & Rivet Shaver**

53-10-1224X



*Four Tools  
In One*

- Versatile front exhaust unit can be used for weld shaving, POP & blind rivet bolt trimming, disc sanding or right angle grinding.
- Height of cut can be controlled to a tolerance of 0.001" or less.
- Accepts 1/4" shank sanding & grinding tools.

Part Number	Free RPM
53-10-1224X	12,000
53-10-1230X	20,000

**End Cut Replacement Cutters - 1/4" Shank, 1-7/8" O.A.L.**

Part No.	Type	Style	Used For	Dia.
14-1732	Carbide	Inverted Cone	Steel Rivets	3/4"
14-1330	H.S.S.	Inverted Cone	Aluminum Welds	3/4"
14-1332	Carbide	Cylindrical	Shaving Welds	1/2"

**Limited Access Rivet Shaver**



*Made In The USA*

- 4" extension is perfect for limited access applications.
- Shaves clean & precise regardless of rivet height.

*9/16" Skirt & Stabilizer Included*

**Pistol Grip 0.75 hp (0.56 kW) - 18,000 RPM**

Part Number	Capacity	Overall Length	Weight
US7387RSE	1/2"	10-3/4" (273 mm)	3.5 lbs (1.6 kgs)

**Rivet Shaver Skirts**

*Highly Polished  
Working Surfaces  
Prevent Marring*



Dotco Type	Sioux Type	Body Diameter
14-4391	2925-5	5/16"
14-4392	2925-6	3/8"
14-4393	2925-7	7/16"
14-4394	2925-8	1/2"
14-4395	2925-9	9/16"
14-4396	2925-10	5/8"
14-4397	2925-11	3/4"
14-4410	—	1"
14-4412	—	1-1/4"

**Rivet Shaver Carbide Cutters**

02-A800-4  
Coarse Cut



02-A900-4  
Fine Cut



**Coarse Cut**

- Solid carbide blade.

**Fine Cut**

- Fourteen flute center cutting design.
- Self-centering solid carbide head eliminates chatter and increases operator control.

**Coarse Cut, 1/4"-28 Thread**

Part Number	Body Dia.
02-A800-1	5/16"
02-A800-2	3/8"
02-A800-3	7/16"
02-A800-4	1/2"
02-A800-5	9/16"
02-A800-6	5/8"
02-A800-7	3/4"
02-A800-8	7/8"
02-A800-9	1"
02-A800-10	1-1/4"

**Fine Cut, 1/4"-28 Thread**

Part Number	Body Dia.
02-A900-2	3/8"
02-A900-4	1/2"

*Precision Ground  
For Chatter-Free  
Cuts & Longer Life*

**Economy Pneumatic Nibbler**



*Clean, Distortion Free Cuts*

- Easily cuts circles & contoured shapes.
- Teasing throttle & hardened planetary gears.
- Cutting head 360° adjustable in 90° increments.

**Lever Grip - 0.5 hp (0.37 kW) - 2600 SPM, 6 FPM**

Part Number	Cap. (steel)	Overall Length	Weight
JSM-213	18 Gauge	7" (178 mm)	2.2 lbs (1.0 kgs)

**Replacement Punch & Dies**

Part Number	Description
21340	Punch
21341	Die

## MATERIAL REMOVAL TOOLS

### Sioux® Pneumatic Nibbler

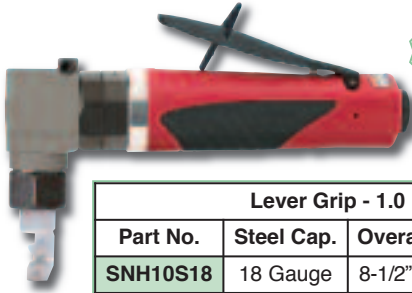

**NEW**

- 18 gauge cold rolled steel capacity.
- Safety lever lock.
- Rear exhaust.

#### Lever Grip - 1.0 hp (0.75 kW)

Part No.	Steel Cap.	Overall Length	Weight
SNH10S18	18 Gauge	8-1/2" (215 mm)	2.65 lbs (1.2 kgs)

### Sioux® Pneumatic Shears

*Cuts Curves & Straight Lines*

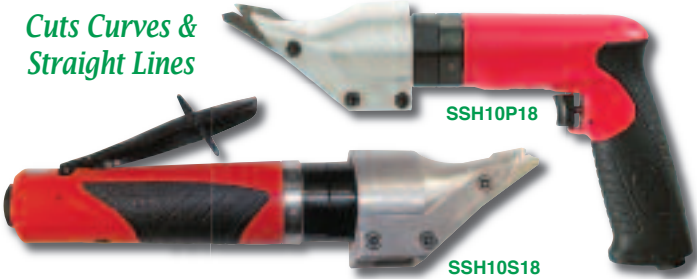

SSH10P18

SSH10S18

Excellent for sheet metal work - also plastic & similar mat. to 3/32".

#### Pistol Grip 1.0 hp (0.75 kW)

Part No.	Cap. Steel	SPM	O.A.L.	Weight
SSH10P18	18 Gauge	2,600	10" (255 mm)	2.9 lbs (1.3 kgs)

#### Lever Grip 1.0 hp (0.75 kW)

Part No.	Cap. Steel	SPM	O.A.L.	Weight
SSH10S18	18 Gauge	2,600	11" (280 mm)	2.75 lbs (1.25 kgs)

### Dewalt® Cordless Power Shear Kit



*360° Swivel Head*

- Powerful & convenient cordless operation.
- Head swivels 360° for great control & access to tight quarters.
- Cuts 7/32" strip that curls away for consistent & accurate cuts.

#### Includes:

Cordless Shears, 1-Hour Charger, Two 14.4V Battery Packs, Blade Wrench & Heavy-Duty Kit Box

Part No.	Steel Cap.	Min. Radius	SPM	Tool Weight
70356	18 Gauge	5-1/2"	0 to 2300	5.8 lbs (2.6 kgs)

### EC® Reversible Trim Shears

*Quick & Powerful*

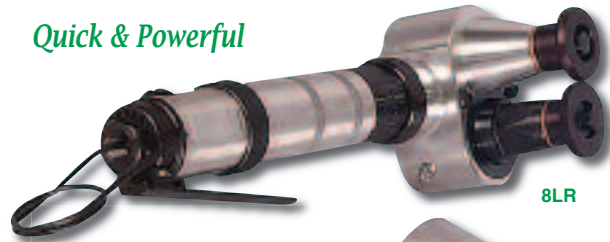

8LR

- Reversible motor allows for versatile shearing & makes it easy to back out of jams.



9PR

- Designed to cut steel, stainless steel, titanium, inconel & similar metals.

#### Lever Grip Trim Shears

Part Number	Mild Steel Capacity	Throat Capacity	Approx. Feed Rate	Weight
7LR	13 Gauge	1-1/4"	8 ft-min.	4.5 lbs (2.0 kgs)
8LR	14 Gauge	2-1/4"	8 ft-min.	5.5 lbs (2.5 kgs)

#### Pistol Grip Trim Shears

Part Number	Mild Steel Capacity	Throat Capacity	Approx. Feed Rate	Weight
7PR	13 Gauge	1-1/4"	8 ft-min.	5 lbs (2.3 kgs)
8PR	14 Gauge	2-1/4"	8 ft-min.	5.5 lbs (2.5 kgs)
9PR	10 Gauge	2-1/2"	3.5 ft-min.	12.5 lbs (5.7 kgs)
10PR	.080" Inconel	2"	3.5 ft-min.	19 lbs (8.6 kgs)

#### Replacement Feed Cutters

Part Number	For Tool
02-9097	7LR to 8PR
02-9280	9PR
02-9915	10PR

#### Replacement Roll Cutters

Part Number	For Tool
02-9098	7LR & 7PR
02-9101	8LR & 8PR
02-9279	9PR
02-9914	10PR



*For Hand Snips, Shears & Nibblers See Pages 156-160*

**Kett® Heavy-Duty Pneumatic Scissor**

*Powerful & Easily Maneuverable*



*Variable Speed*

- Specially designed for fast, accurate cutting of mild steel (to 24 gauge), wire mesh (to 18 gauge), soft plastic or rubber (to 1/4"), rigid PVC & other plastics (to 1/8").
- Unique swiping action leaves a clean edge without fouling.

Part No.	Cap. Mild Steel	RPM	Overall Length	Weight
P-2041	24 Gauge	0-2500	11-3/4" (299 mm)	5.0 lbs (2.3 kgs)

Note: Replacement blades available, please inquire.

**Utility Cut-Off Tool**

*New Aluminum Housing Design*



*Cuts Metal To 3/4" Thick*

- 360° rotating spark guard & safety lock throttle.
- Built-in speed regulator & ball bearing construction.



0.5 hp (0.37 kW), 3/8" Arbor			
Part Number	Free RPM	O.A.L.	Weight
90397	22,000	7-5/16" (186 mm)	1.98 lbs (0.9 kgs)

**Replacement Cutting Discs**

- Small Type 1, double reinforced resinoid cut-off discs.
- Super thin (.035"), provides a clean, fine-finished burr free cut.

122059

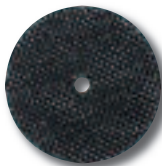

1/4" Arbor Disc	3/8" Arbor Disc	Diameter	Max. RPM
122057	122058	2"	30,000
122059	122060	3"	25,000
122061	122062	4"	19,000

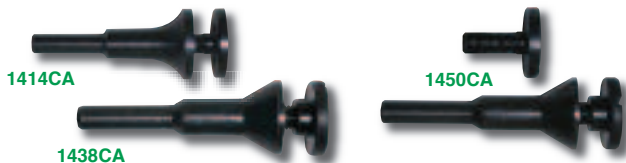

1414CA

1438CA

1450CA

**1/4" Shank Cutting Disc Mandrels**

- 1450CA includes the 1/4" shank mandrel and both 1/4" & 3/8" arbor endpieces (for use with 1/4" & 3/8" arbor discs).

Mandrel & 1/4" Arbor	Mandrel & 3/8" Arbor	Mandrel & Both Arbors
1414CA	1438CA	1450CA

**Tab Shear**

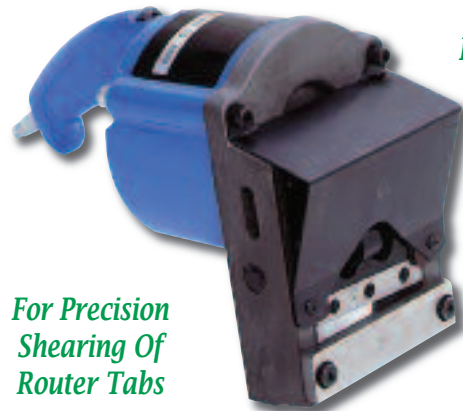

*Regrindable Tool Steel Blades*

*For Precision Shearing Of Router Tabs*

- Full length bosses with bolts & self-locking nuts.
- Hard anodized aluminum frame with carbide wear faces.

Note: Replacement blades available, please inquire.

Part Number	Capacity (steel - alum.)	Max. Throat Opening	Shearing Force	Weight
650	1/16" - 3/32"	1/8" x 3" (area)	4,200 lbs (1,905 kgs)	7.0 lbs (3.2 kgs)

**Dotco® Straight Routers**

12L1001-36RT



Note: Router guide shown not included, please see page 101 to order.

Front Exhaust 0.3 hp (.22 kW)				
Part Number	Free RPM	Shank Cap.	O.A.L.	Weight
12L1001-36RT	34,000	1/4"	6-3/4"	1.4 lbs (0.6 kgs)
12L1000-36RT	30,000	1/4"	(172 mm)	

Front Exhaust 0.6 hp (.45 kW)				
Part Number	Free RPM	Shank Cap.	O.A.L.	Weight
12L2000-01RT	25,000	1/4"	7-1/2"	1.9 lbs (0.9 kgs)
			(191 mm)	

Rear Exhaust 0.6 hp (.45 kW)				
Part Number	Free RPM	Shank Cap.	O.A.L.	Weight
12L2080-01RT	25,000	1/4"	7-1/2"	1.9 lbs (0.9 kgs)
			(191 mm)	

Front Exhaust 0.9 hp (.67 kW)				
Part Number	Free RPM	Shank Cap.	O.A.L.	Weight
12L2500-01RT	23,000	1/4"	7-1/8"	2.6 lbs (1.2 kgs)
			(181 mm)	

Rear Exhaust 0.9 hp (.67 kW)				
Part Number	Free RPM	Shank Cap.	O.A.L.	Weight
12L2580-01RT	23,000	1/4"	7-1/8"	2.6 lbs (1.2 kgs)
12L2580-0124RT	23,000	3/8"	(181 mm)	

## MATERIAL REMOVAL TOOLS

### Dotco® High Power Straight Router

12L4018-01



Front Exhaust 1.7 hp (1.27 kW)

Part Number	Free RPM	Shank Cap.	O.A.L.	Weight
12L4018-01	18,000	1/4"	11-3/8" (289 mm)	4.2 lbs (1.9 kgs)

### Dotco® High Power Routers w/Base Mount



10T4318-62

Rear Exhaust 1.7 hp (1.27 kW) With Base Mount

Part Number	Free RPM	Shank Cap.	O.A.L.	Weight
10T4318-62	18,000	1/2"	7-1/8" (181 mm)	7.4 lbs (3.4 kgs)
10T4316-62	16,000			
10T4309-62	9000			

Rear Exhaust 1.7 hp (1.27 kW) Power Unit Only

Part Number	Free RPM	Shank Cap.	O.A.L.	Weight
11T4318-62	18,000	1/2"	7-1/8" (181 mm)	5.5 lbs (2.5 kgs)

### Dotco® Two Handed Router Base

*Easy Depth Adjustment*



- For use with either front or rear exhaust models on previous page.
- Can also be used with 10-43 template guides, please inquire.

Part Number	For Series
14-1577	12-10
14-2577	12-20 & 12-25

### Dotco® Router Assemblies



14-2180

- All assembly components available separately, please inquire.
- For use with Dotco straight routers shown on previous page.

For 12-10 Series Type Routers

Part Number	Thread Size	Cutter Shank Dia.
14-2187	1/4"-20	1/4"

For 12-20 & 12-25 Series Type Routers

Part Number	Thread Size	Cutter Shank Dia.
14-2180	1/4"-20	1/4"
14-2429	5/8"-18	3/8"

### H.S.S. Taper Router Bits



For clearance cutting or routing & trimming of aircraft assemblies.

Part Number	Size	Point Dia.	Shank Dia.
02-0228	1	.081"	.098"
02-0221	2	.110"	.128"
02-0213	3	.165"	.1875"
02-0209	4	.224"	.250"



53-1492

#### Taper Router Kit:

Four Routers (one each above) & Plastic Case (not shown)

Part Number	Description
53-1492	Complete 5 PC Kit

### H.S.S. Aircraft Router Bit



For routing and trimming aluminum, non-abrasive plastics and similar materials

2 Downcut Flutes with Drill Point, Left Hand Helix, Right Hand Cut

Part Number	Shank Diameter	Overall Length
02-17251	1/4"	2-3/8" (60 mm)

**Solid Carbide Router Bits**



For edge routing when the end is not in contact with the work piece.

Diamond Pattern, Right Hand Cut, No End Cut		
Part Number	Shank Diameter	Overall Length
02-1547-3/16	3/16"	2" (51 mm)
02-1547-1/4	1/4"	2-1/2" (64 mm)
02-1547-3/8	3/8"	2-1/2" (64 mm)
02-1547-1/2	1/2"	3" (76 mm)

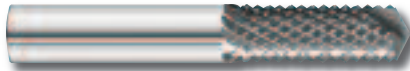

- Drill point plunges through the work piece before routing begins.
- Designed to produce an even edge & leave burr-free surfaces.

Diamond Pattern, 135° Drill Point End		
Part Number	Shank Diameter	Overall Length
02-1547A-3/16	3/16"	2" (51 mm)
02-1547A-1/4	1/4"	2-1/2" (64 mm)
02-1547A-3/8	3/8"	2-1/2" (64 mm)
02-1547A-1/2	1/2"	3" (76 mm)

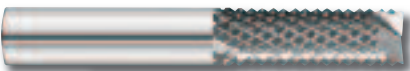

For bottom cuts requiring a smooth surface & square corners.

Diamond Pattern, End Mill End Cut		
Part Number	Shank Diameter	Overall Length
02-1547B-3/16	3/16"	2" (51 mm)
02-1547B-1/4	1/4"	2-1/2" (64 mm)
02-1547B-3/8	3/8"	2-1/2" (64 mm)
02-1547B-1/2	1/2"	3" (76 mm)



Diamond Pattern, Burr Style End Cut		
Part Number	Shank Diameter	Overall Length
02-1547C-3/16	3/16"	2" (51 mm)
02-1547C-1/4	1/4"	2-1/2" (64 mm)
02-1547C-3/8	3/8"	2-1/2" (64 mm)
02-1547C-1/2	1/2"	3" (76 mm)



2 Flute Pattern, Left Hand Spiral, Right Hand Cut, No End Cut		
Part Number	Shank Diameter	Overall Length
02-1541-3/16	3/16"	2" (51 mm)
02-1541-1/4	1/4"	2-1/2" (64 mm)
02-1541-3/8	3/8"	2-1/2" (64 mm)
02-1541-1/2	1/2"	3" (76 mm)

**Dotco® Router Guides**

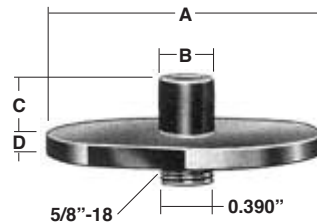

*For 3/8" Shank Bits*

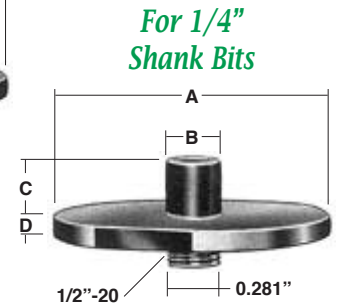

*For 1/4" Shank Bits*

For 1/4" Shank Bits				
Part No.	'A'	'B'	'C'	'D'
14-2703	3/4"	3/8"	1/2"	1/8"
14-2400	1"	3/8"	1/8"	1/8"
14-2401	1"	3/8"	1/4"	1/8"
14-2402	1"	3/8"	3/8"	1/8"
14-2406	1"	7/16"	1/8"	1/8"
14-2407	1"	7/16"	1/4"	1/8"
14-2408	1"	7/16"	1/2"	1/8"
14-2411	1"	1/2"	1/4"	1/8"
14-2412	1"	1/2"	1/2"	1/8"
14-2413	1"	1/2"	5/8"	1/8"
14-2414	1"	1/2"	3/4"	1/8"
14-2417	1"	9/16"	1/8"	1/8"
14-2420	1"	5/8"	1/8"	1/8"
14-2421	1"	5/8"	5/8"	1/8"
14-2500	1-1/2"	3/8"	1/8"	1/8"
14-2501	1-1/2"	3/8"	1/4"	1/8"
14-2502	1-1/2"	3/8"	3/8"	1/8"
14-2505	1-1/2"	7/16"	1/8"	1/8"
14-2506	1-1/2"	7/16"	1/4"	1/8"
14-2507	1-1/2"	7/16"	3/8"	1/8"
14-2510	1-1/2"	1/2"	1/4"	1/8"
14-2511	1-1/2"	1/2"	3/8"	1/8"
14-2512	1-1/2"	1/2"	1/2"	1/8"
14-2600	1-1/2"	1/2"	1/2"	3/16"

For 3/8" Shank Bits				
Part No.	'A'	'B'	'C'	'D'
14-2531	1-1/2"	1/2"	3/8"	1/8"
14-2538	1-1/2"	1/2"	1/2"	1/8"
14-2539	1-1/2"	1/2"	5/8"	1/8"
14-2540	1-1/2"	9/16"	3/8"	1/8"
14-2541	1-1/2"	9/16"	1/2"	1/8"
14-2542	1-1/2"	9/16"	1/2"	1/8"
14-2893	1-1/2"	5/8"	3/8"	1/8"
14-2925	1-1/2"	5/8"	1/2"	1/8"
14-2544	1-1/2"	5/8"	5/8"	1/8"
14-2240	2-1/2"	1/2"	3/8"	1/8"
14-2632	2-1/2"	1/2"	1/2"	1/8"
14-2633	2-1/2"	1/2"	5/8"	1/8"
14-2634	2-1/2"	9/16"	3/8"	1/8"
14-2630	2-1/2"	9/16"	1/2"	1/8"
14-2635	2-1/2"	9/16"	5/8"	1/8"
14-2243	2-1/2"	5/8"	3/8"	1/8"
14-2636	2-1/2"	5/8"	1/2"	1/8"
14-2631	2-1/2"	5/8"	5/8"	1/8"