

T60 Cable Tensiometer Instruction Manual

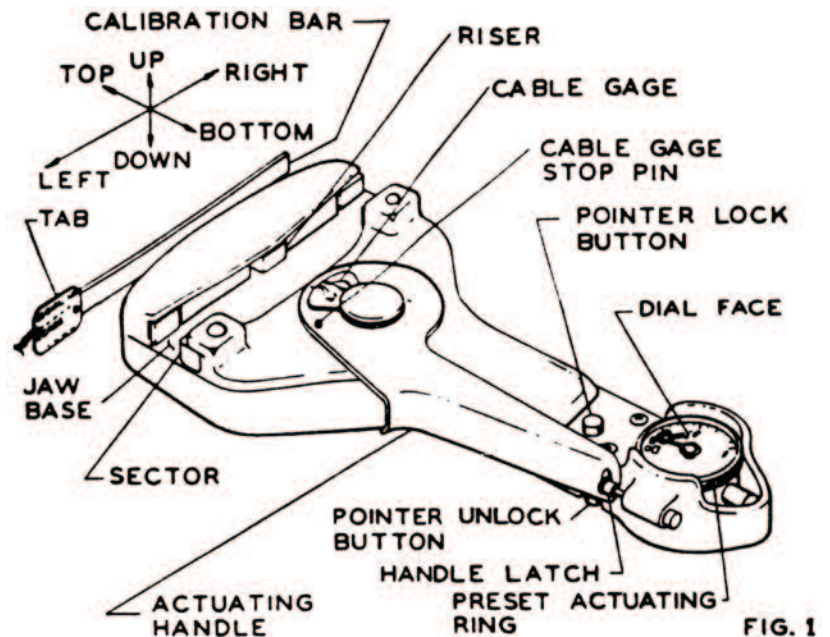

Identification

PACIFIC Type T60-1001-C8-1A Tensiometer

- USAF Equivalent - Type C-8 Range: 10-200 lbs.

PACIFIC Type T60-1001-C9-1A Tensiometer

- USAF Equivalent - Type C-9 Range: 150-450 lbs.

General Instructions

Before Using Instrument: Study diagram, figure 1, in order to become familiar with nomenclature and part orientation. Either the right hand or the left hand may be used to operate this instrument. Actuating Handle is retained by Handle Latch. This latch is automatically released when the Actuating Handle is squeezed. To relatch handle, the Actuating Handle is slowly released against the Handle Latch. The latch end will be retained in the detent socket provided in the actuating handle.

Warning: When relatching Actuating Handle it must be determined that the latch is in the Detent Socket before releasing the handle. In actuating the Instrument Handle to obtain cable tension readings, **the handle should never be allowed to snap open**. It should be released gradually, allowing the unit to clamp firmly on the cable.

Do not attempt to take cable tension readings with the Pointer Lock Button depressed. See figure 1. If the Pointer Lock Button is depressed during tension reading, a false reading will result do to the friction of the brake mechanism.

Overload: The tensiometer cannot be damaged by use on cables loaded in excess of the amount indicated by the dial on the tensiometer.

For Greatest Accuracy: Due principally to the uneven surface of stranded cable, slight variations in reading may occur on the same cable as the same tension. This is particularly true of 5/32" diameter cable and larger. To obtain the greatest possible accuracy, it is recommended that three to five readings be taken at slightly different locations on the cable and these values averaged. This will tend to eliminate the effect of cable variation and obtain the maximum degree of accuracy.

Type of Cable: The T60 Tensiometer is calibrated for use on standard multiple strand aircraft cable of 7 x 7 stranding in sizes of 1/16" and 3/32", and 7 x 19 stranding for 1/8" through 1/4" cable diameter. If it is necessary to use this instrument on cables of a different construction, the user should contact the nearest Pacific Scientific Company office for correction tables. Complete specifications of the type of cable must be specified.

Toll Free Nationwide & Canada: **800-645-8180**

USATCO\U.S. AIR TOOL COMPANY, INC. WWW.USATCO.COM NEW YORK • CALIFORNIA

Rev0415

Instruction Manual

Warning: Use of Tensiometer on Cable Systems Equipped with Cable Tension Regulators

Cable Tensiometers should not be used for adjusting the rig load in a cable system where an automatic cable tension regulator is installed. In all cases, such cable systems should be rigged by adjusting them so that the pointer on the cable tension regulator scale indicates the correct number based on the surrounding temperature as indicated on the chart provided in the Airplane Service Manual. The Tensiometer may be used to check the tension so obtained but it must be remembered that the actual cable tension will vary from the nominal depending upon the errors in the instrument itself, manufacturing tolerance of springs in the regulators, rate of the regulator spring and condition of the control cable. Cable tension readings taken on regulated control systems by means of a Tensiometer could, therefore, be misleading.

To Take Readings:

1. To measure cable diameter:

- a. With the Actuating Handle in the latched position, move the cable Gage to the left against the Cable Gage Stop Pin
- b. Release the Handle Latch by squeezing the Actuating Handle. Retain the Actuating Handle unlatched against the side of the Tensiometer. Place instrument on the cable, making certain that the cable is squarely aligned in the Jaws. Care should be taken that the cable is resting flat against the Jaw Base. Slowly release the Actuating Handle, allowing the Cable Jaw to slide up and grip the cable. Remove all restraint from Actuating Handle.
- c. Remove Tensiometer from the cable by returning Actuating Handle to the latched position. The cable diameter is indicated by the black line opposite a position on the Cable Gage.

2. To take Tension Readings:

- a. **Type C-8 — To Pre-set Dial:** Rotate knurled rim of pre-set dial until the pointer is directly over the white square corresponding to the cable diameter. At this point, it will be noted that for the larger size cables there are two rows of pre-set squares. One row is identified by 125⁻; the other indicated by 125⁺. In measuring tensions below 125 lbs. use corresponding squares in row indicated 125⁻. In measuring tension in excess of 125 lbs. use corresponding squares in row indicated 125⁺ (see figure 2). With the dial properly aligned with the correct cable size, repeat step 1b.

Figure 2. Pre-set Instructions for type C-8 Instrument. For type C-9 Instruments, use Similar Procedure

Set pointer here when reading tension loads in excess of 125 lbs.



Set pointer here when reading tension loads less than 125 lbs.

Type C-8 — To Pre-set Dial: Rotate knurled rim of pre-set dial until the pointer is directly over the white square corresponding to the cable diameter. At this point, it will be noted that for the larger size cables there are two rows of pre-set squares. One row is identified by 250⁻; the other indicated by 250⁺. In measuring tensions below 250 lbs. use corresponding squares in row indicated 250⁻. In measuring tension in excess of 250 lbs. use corresponding squares in row indicated 250⁺ (see figure 2). With the dial properly aligned with the correct cable size, repeat step 1b.

- b. **To Read Cable Tension:** With the tensiometer clamped on the cable, the tension is read directly by pointer position on the dial face. To remove the Tensiometer, compress the Actuating Handle firmly against the side of the Tensiometer.

Manipulation for Difficult Locations

In taking readings among closely grouped cables or in awkward or blind locations, let the Actuating Handle remain open with the instrument clamped on the cable. With the instrument thus clamped in this position, press the Pointer Lock Button down. Remove the Tensiometer by compressing the Actuating Handle against the side of the case and remove. The dial indicator pointer will be locked in a position directly over the tension reading obtained on the cable. To release this reading, press up on Pointer Unlock Button (see figure 1).

Use of Calibration Bar

A Calibration Bar is supplied with each Tensiometer, thus providing an immediate means of checking the accuracy of the instrument on the job. This bar has been carefully calibrated to read the load marked on the Identification Tab. Careful attention should be paid to the position of the bar in the instrument.

Locate as Follows: Grasp the Calibration Bar Identification Tab in the left hand. Place the bar in the instrument with the Identification Tab facing the operator (toward bottom of instrument). In this position, the calibration reading will be visible. Pre-set the dial to the smallest cable size noted; then slowly release the Actuating Handle, allowing the Jaws to grip the Calibration Bar. Repeat several readings and average. The average reading thus obtained on the dial should correspond with the reading marked on the Identification Tab.

Repairs: In the event that the instrument becomes damaged, or worn out, and repairs are indicated, consult T.O. 33A3-3-3-21, 33A3-3-3-24 for instructions or return the instrument to USATCO.

*It is recommended that tensiometers be calibrated annually to ensure proper functioning of the device.
Send tensiometers to our New York office listed below.*

USATCO U.S. Air Tool Company, Inc.

Eastern Division60 Fleetwood Ct., Ronkonkoma, NY 11779-6907 tel: (631) 471-3300 fax: (631) 471-3308

Western Division1219 W. Mahalo Place, Rancho Dominguez, CA 90220-5446 tel: (310) 632-5400 fax: (310) 632-3900