

750 Tab Shear Parts List



- For precision shearing of router tabs.
- Full length bosses with bolts & self-locking nuts.
- Hard anodized aluminum frame with carbide wear faces.
- Tool steel blades are regrindable.
- Replacement blades are available, please inquire.

Air Line Lubrication

An automatic in-line filter-lubricator is recommended as it increases tool life and provides needed lubrication for tools in sustained operation. The in-line lubricator should be regularly checked and filled with a good grade of 10 weight machine oil. Proper adjustment of the in-line lubricator is performed by placing a sheet of paper next to the exhaust ports of the tool and holding the throttle open for approximately one minute. The lubricator is set correctly when a very light stain of oil collects on the paper. Excessive amounts of oil should be avoided.

In the event that it becomes necessary to store the tool for an extended amount of time it should receive a generous amount of lubrication at that time and again when returned to service. The tool should be stored in a clean and dry environment. Care should be taken to absorb any excess oil from the exhaust with a suitable cloth or rag when the tool is first run with air after storage.

Gear Train Lubrication

Application of the tool should govern how frequently it is greased. It is recommended that the gear cases receive several squirts of No. 2 moly grease after 40 hours of operation.

Attachment Lubrication

The attachments of the tool should be greased once a day if used in sustained operation. Failure to lubricate attachments will cause premature wear and short attachment life.

Air Supply

Our tools are designed to operate at 90 pounds per square inch air pressure. The pressure should be checked at the tools inlet with the tool running. For maximum performance use a 1/4" inside diameter air hose up to 8' in length. If additional length is required a 3/8" inside diameter or larger should be connected to the 1/4" I.D. hose. All hoses should be clear of dirt and moisture.

Toll Free Nationwide & Canada: **800-645-8180**

USATCO\U.S. AIR TOOL COMPANY, INC. www.USATCO.COM NEW YORK • CALIFORNIA

Rev0715



USATCO
U.S. Air Tool Co.

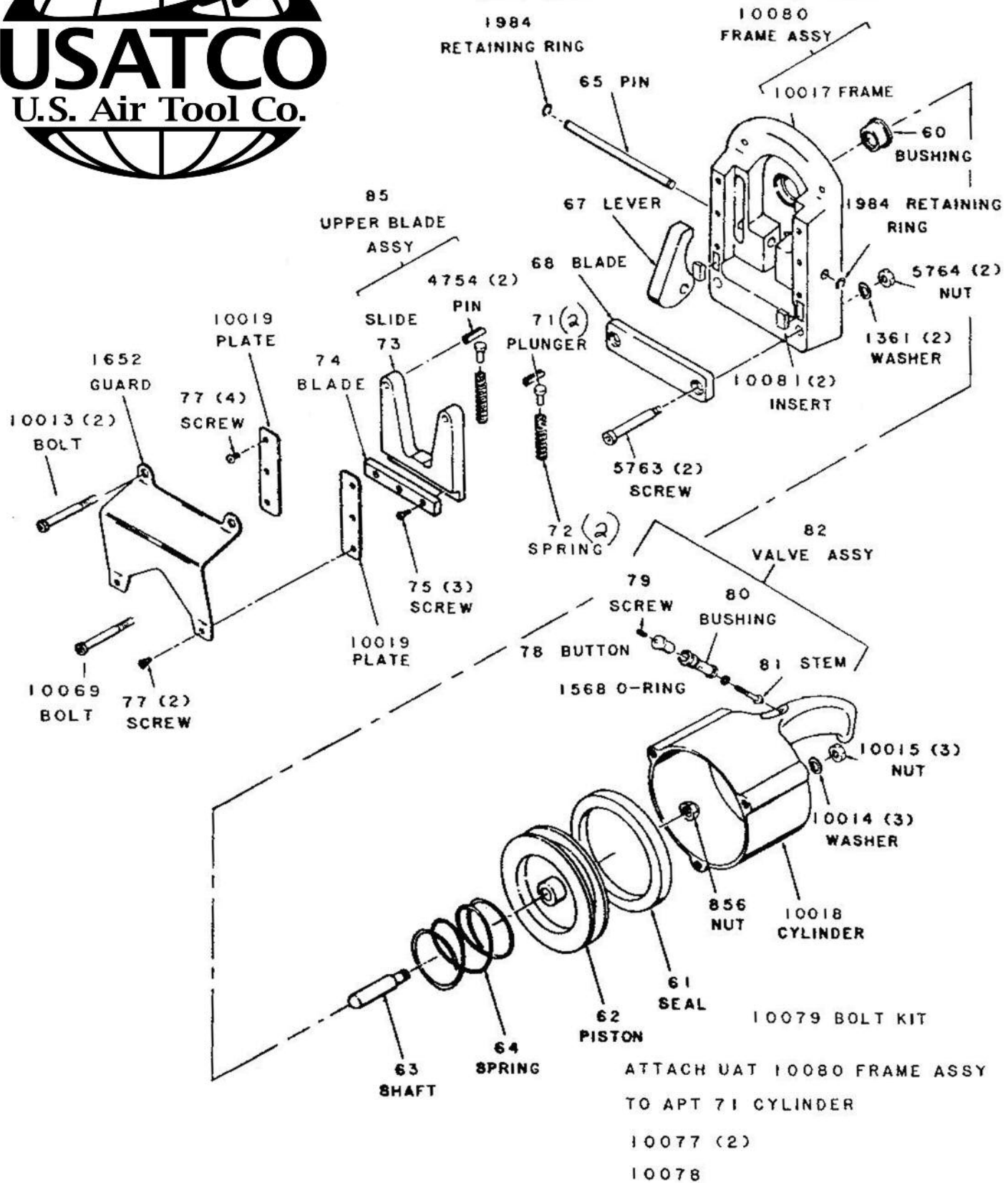

USATCO\U.S. Air Tool Company, Inc.

Eastern Division60 Fleetwood Ct., Ronkonkoma, NY 11779-6907 tel: (631) 471-3300 fax: (631) 471-3308
Western Division1219 W. Mahalo Place, Rancho Dominguez, CA 90220-5446 tel: (310) 632-5400 fax: (310) 632-3900