

USATCO Rivet Guns (.498" Shank) Parts List & Instructions For Use



1. Keep Work Area Clean

Cluttered areas and benches invite accidents.
Keep work areas well lit.

2. All Visitors Should be Kept a Safe Distance from Work Area.

3. Don't Force Tool

It will do the job better and safer at the rate for which it was designed.

4. Use Right Tool

Don't force a tool or an attachment to do a job that it was not designed for.

5. Use Safety Glasses

Always use safety glasses with this tool.

6. Don't Abuse Hoses or Connectors

Never carry tool by the hose or yank it to disconnect from power supply. Keep hose from heat, oil and sharp edges.

7. Pressure Rating

Do not exceed maximum operating pressure.

8. Don't Overreach

Keep proper footing and balance at all times.

9. Maintain Tools with Care

Keep tools clean and oiled, for best and safest performance. Follow instructions for lubricating and changing accessories. Wiping or cleaning and other flammable waste materials must be placed in a tightly closed metal container and disposed of later in the proper fashion.

10. Disconnect Tools

When not in use, or when changing accessories.

OPERATION

Caution: Maximum operating pressure is 90 psi.. Never use higher air pressures to increase the output of the Air Hammer. Overloading will drastically shorten the life of all internal parts.

Daily, before using and before putting tool into operation, disconnect air hose and put a small amount of recommended oil (see lubrication) into tool air inlet. Blow out air line to clear it of accumulated dirt and moisture, connect tool and operate on low throttle to allow oil to be carried to the interior of the tool.

Always place a Rivet Set in the hammer and hold the tool down to the work before operating. Damage to the tool or retainer may result if this precaution is not followed. The chisel retainers are not designed for complete safety against accidental release of cutters or hammers. To avoid injury, the trigger must never be depressed unless the chisel is held firmly against the work piece. When the tool is not in actual use, the tool must be removed. During operation, **Safety Goggles should always be used to guard against flying chips.**

MAINTENANCE

Caution: Disconnect Air Hammer from power air before servicing.

Do not penalize the operator by requiring him to use a tool which is not in first class condition. A regularly scheduled inspection and repair program will correct minor faults, avoid extensive repairs and maintain the tool at it's highest efficiency.

1. Keep tool properly lubricated.
2. Provide 90 psi. of clean, dry air **at the tool.**
3. Use hose and connections of proper size and good condition.
4. Set up and maintain a repair, and replacement program scheduled at regular intervals.

LUBRICATION

The use of an Air Line Filter-Regulator-Lubricator installed at the end of each air pipe leading to this pneumatic tool is recommended to assure a constant, adequate supply of clean air and lubricant to the valve and cylinder. Recommended Lubricants: USATCO'S Air Motor Lubricating Oil or a turbine or spindle grade oil with a viscosity of 100-150 S.U.S. at 100° F which contains a rust inhibitor.

Toll Free Nationwide & Canada: **800-645-8180**

USATCO\U.S. AIR TOOL COMPANY, INC. WWW.USATCO.COM NEW YORK • CALIFORNIA

Rev0219

Parts List

CAUTION: Do not disassemble tool before removing index numbers 18, 20, 21 & 22 first!

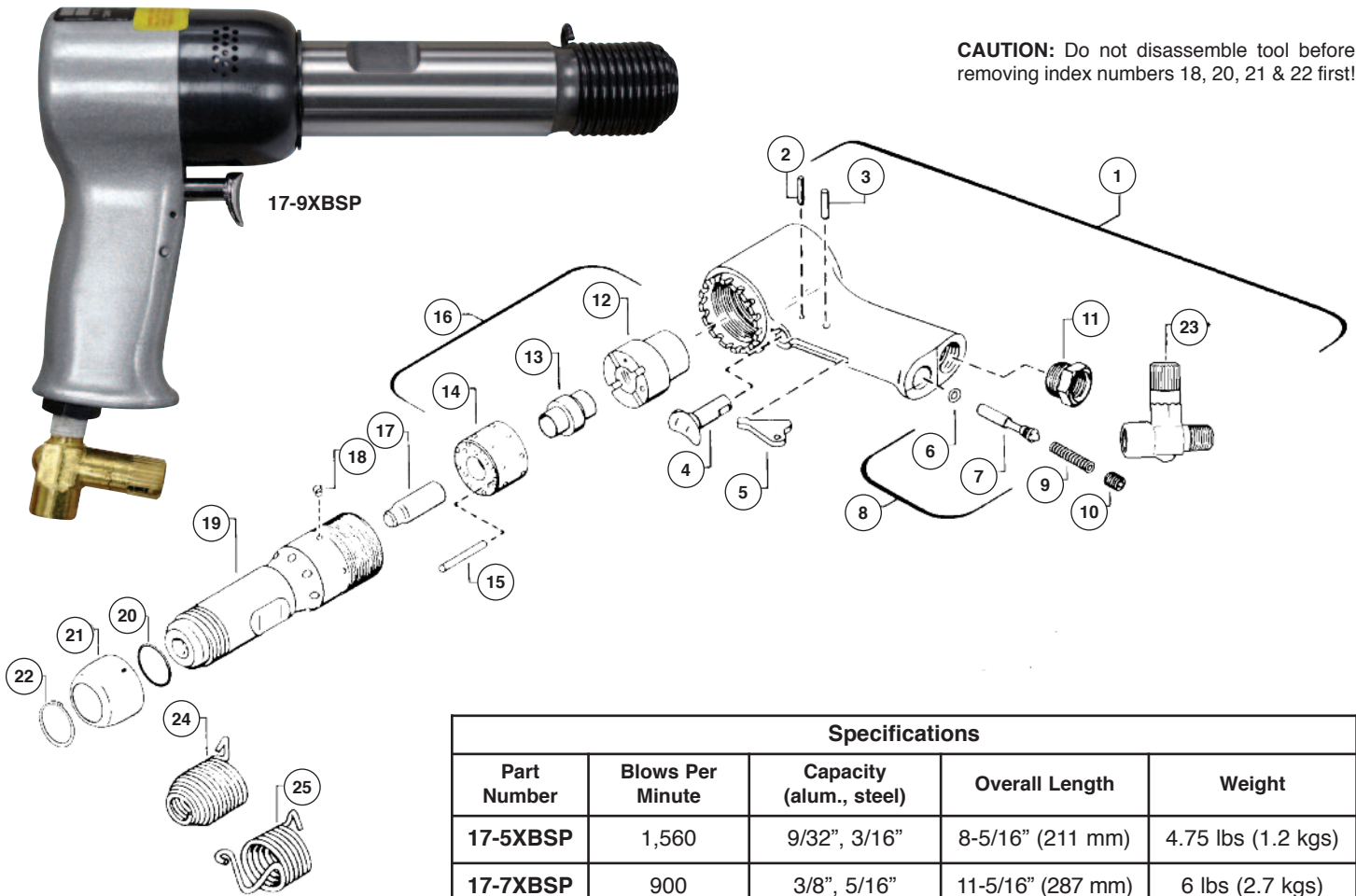

Specifications				
Part Number	Blows Per Minute	Capacity (alum., steel)	Overall Length	Weight
17-5XBSP	1,560	9/32", 3/16"	8-5/16" (211 mm)	4.75 lbs (1.2 kgs)
17-7XBSP	900	3/8", 5/16"	11-5/16" (287 mm)	6 lbs (2.7 kgs)
17-9XBSP	1,140	5/16", 1/4"	9-5/16" (237 mm)	5.125 lbs (2.3 kgs)

Index	Part No.	Description	Qty.
1	38-91864	Handle - Complete Assembly (includes 2, 3, 4, 5, 8, 9, 10, 11 & 22)	1
2	38-91865	Pin - Lever Stop	1
3	38-91866	Pin - Lever	1
4	38-91867	Button - Lever Push	1
5	38-91868	Lever - Valve	1
6	38-91869	"O" Ring (-700)	1
7	38-91870	Body - Valve (throttle)	1
8	38-91871	Valve - Throttle Complete (incl. 6 & 7)	1
9	38-91872	Spring - Valve	1
10	38-91873	Plug - Throttle Tube	1
11	38-91874	Bushing - Inlet	1
12	38-91875	Lid - Valve Case	1
13	38-91876	Valve	1

Index	Part No.	Description	Qty.
14	38-91877	Case - Valve	1
15	38-91878	Valve - Dowel Case	1
16	38-91879	Case - Valve Complete (incl. 12-15)	1
17	38-91880	Piston	1
18	38-91881	Pin - Cylinder Lock	1
19	38-91882	Barrel With Set Sleeve (5XSP)	1
	38-91883	Barrel With Set Sleeve (7XSP)	
	38-91884	Barrel With Set Sleeve (9XSP)	
20	38-91886	"O" Ring	1
21	38-91885	Exhaust Deflector	1
22	38-91887	Retainer Ring	1
23	09-140	Power Regulator	1
24	09-RB-4	Beehive Retainer Spring	1
25	09-RH-4	Handi Type Retainer Spring	1

USATCO\U.S. Air Tool Company, Inc.

Eastern Division60 Fleetwood Ct., Ronkonkoma, NY 11779-6907 tel: (631) 471-3300 fax: (631) 471-3308

Western Division1219 W. Mahalo Place, Rancho Dominguez, CA 90220-5446 tel: (310) 632-5400 fax: (310) 632-3900